

## **Affordable Housing for Benny Farm**

Dr. Avi Friedman, Architect

Research/Design Team

Dong An

Min Shu

Jiahui Wu

August 2003

## Contents

<b>Introduction</b>	1
<b>Background Studies</b>	
▪ Socio-economic Data	5
▪ Affordability Targets	6
▪ Zoning	7
▪ Architectural Context	8
▪ Cost-reduction Strategies	14
<b>Planning Options</b>	
▪ Summary	22
▪ Options	23
▪ Options Analysis	30
<b>Units Design</b>	
▪ Summary	31
▪ Units	32
<b>Conclusions and Recommendations</b>	42

## Introduction

The thrust of this study is housing affordability. We proposed strategies for site planning and units design for the market portion of the Benny Farm project. With spiraling housing costs, the challenge is not an easy one, particularly in a desired neighborhood like Notre Dame de Grace. Montreal's "hot" market conditions did not make the task any easier.

In the study we worked within the parameters of the proposed plan by the winning team of a competition for the site design. We investigated ways through which the dwelling cost could be lowered. We closely followed a methodology that ensured a fit between anticipated buyers and the proposed design. In background studies we examined the socio-economic makeup of NDG and the Benny Farm area residence. It helped us draw a profile of an assumed buyer. This data also helped establish an affordability target, and create cost parameters within which we worked. Recognizing that the proposed project is an infill one, fostered a careful study of the neighborhood architectural context. It led us to a synthesis of issues that we attempted to respect in our design. Required zoning in the study area was another reviewed aspect and one that we learned from.

We continued by listing and identifying most relevant cost reduction strategies and studying their effectiveness. The strategies encompass both macro and micro aspects related to housing. The next stage involved the development of several planning options. We regarded the proposal made by the architects of the Benny Farm design proposal as a departure point and we attempted to increase both density and number of units, and lower cost per dwelling. We also recognized that dwelling diversity is a key to achieving affordability. Designing the dwelling units themselves was the next step. We proposed eight different housing models to enable future developers of the site to make an informed decision. We employed some of the cost reduction strategies that we listed earlier in the design.

In the last phase we drew conclusions and made several suggestions. The principal recommendation is to have the proposed housing stock diversified and the share of the small units increased. The building of duplex and triplex type units will reduce cost and will coincide with the needs of potential buyers in the area, many of whom are single-person households.

## Socio-economic Data

P.5

In order to establish target cost for new housing in the Benny Farm project and to identify potential buyers a study of socio-economic data was taken. The study examined eight key indicators and attempted to draw conclusions as a result.

Examining population trends in the area was the first aspect examined. Statistics indicate that the study area remained popular with positive migration. Between 1996 and 2001, there was a population increase of 2.7% in NDG and 4.7% in the Benny Farm area. The number of units also grew by 9.6% in NDG and 13.6% in the study district. These results are a definite "show of confidence" in the present and future viability of the site. People simply see NDG and Benny Farm as desirable places to reside. There is no doubt that there will be swift demand for the units built.

With regard to households' composition, one can say that the study area has a balanced demographic profile. There are both families with children and without children in NDG. Yet, the share of the small household is fairly substantial. This fact, combined with the need for affordable housing, implies that suggesting large numbers of smaller units will make both demographic and economic sense. There are also a large number of elderly people in the neighborhood. In general, studies show that senior citizens commonly tend to remain in their present location rather than buy a new home at an old age. Yet, one can also expect to see an above average number of elderly people inquiring about a new home.

The largest age segments of the population are the groups of 25-34, 35-44, 45-54. This is no surprise since the last two age groups represent the baby boom generation. One can assume that NDG, Benny Farm or, for that matter, Montreal at large, still have a significant number of boomers who are renting and who wish to acquire their own place. Some of them are more established households who are currently paying high rents and who were able to save the necessary money for a down payment.

The household income in NDG and Benny Farm can be regarded as equivalent compared with the rest of Canada. There are, however, a large number of lower income households as well. In 1996 the average household income in NDG was \$43,000 and lower in Benny Farm: \$34,000. These figures can be explained if one is considering the large number of small households, primarily those made of a single person. In our design we have attempted to meet the needs of these potential buyers with low income.

The share of rental units in NDG is 69%. It is even higher in the Benny Farm area (80%). High rental rate is traditional in Montreal. Yet, in the past two decades we have witness a steady decline in these rates across the Island, a trend that is not apparent in the Benny Farm area. It is an indication that NDG residents are less mobile. Another explanation can lie in the fact that there have not been many affordable housing dwellings built in NDG. It is also possible that most recent units built were not affordable to renters.

The monthly rent paid in 1996 in NDG was \$572 and \$508 in the Benny Farm area. Rents have gone up since then, but these numbers provide an indication of what people can afford if they wish to buy. A common assumption based on studies done by the author is that people can add an additional \$200 to their current rent when they plan to buy. This provides us with an indication of what the monthly payment for new units should be.

The study then examined the types of properties that were sold as of September 2002. The average price of a single-family cottage was \$384,416, that of a condo was \$200,727, a duplex was \$260,787 and a triplex went for \$239,300. These homes can be regarded as unaffordable for the population that we have targeted in our study.

Another aspect studied was the size of units that are currently being offered to renters. The majority of them are made of large size units (5.5-8.5 rooms). Once again, these are likely old stock units which do not represent current demographic needs, nor affordability in the Benny Farm area.

The above information enables us to draw some fundamental conclusions, most notably regarding affordability.

## Affordability Targets

P.6

When affordability targets were set, they were based on the socio-economic data that was outlined above. They were also based on verbal exchanges with Canada Lands representatives. With this information in mind we established low and high targets. The low target was meant to provide homes for people with income equivalent to median income in the Benny Farm area: \$24,454. Based on the size of their down payments, they would be able to afford a unit between \$69,645 and \$81,275. We also examined the needs of an assumed buyer with household income of \$30,000. This household will be able to afford a unit between \$85,440 and \$99,710. A household with an income equivalent to the average in NDG, \$42,655, will be able to afford a unit between \$121,510 and \$141,800. An assumed buyer with high household income for the study area (\$60,000) will be able to afford a unit with a cost of \$170,885 and \$199,415.

The focus of our affordability target selling price was to offer a range of cost options to buyers. We bore in mind a variety of factors that influence affordability as well as a range of other expenses that buyers will incur during their residency.

## Zoning

P.7

In studying the relevant zoning for the site and later preparing proposals, the authors were aware that the project would be submitted as "Planned Unit Development (Plan d'ensemble)". It was recognized that the current zoning can eventually be altered. We attempted, however, to respect existing zoning and bylaws as much as we could.

The aspects that we paid attention to included building width, where one can construct buildings 4.2 m wide if they are attached. We also looked at Building Lines and Set Backs. At least 80% of the façade material must be covered with brick, a common building material in NDG. Size of openings and dimensions of projections were other topics examined. Parking, a critical issue in high density projects, was also studied. In a Proposed Planning Index of the winning entry several recommendations were made, a kind of zoning synthesis for the site, which we considered as well.

## Architectural Context

P.8

One of the key features of an infill project is how well it fits with its surrounding architecture. In order to ensure that our proposed design would fit with local design, the study undertook a survey of some main elements that provide good indicators of what the district's architectural character is. We concentrated primarily on streets neighboring the site.

Two main building types were identified when the typology of the building was examined: single family dwelling and duplex. The buildings themselves are grouped as detached and semi-detached structures. The building front setback is fairly consistent throughout the neighborhood and it ranges between 3.75 m and 4.5 m. The building height is also consistent throughout the area. With the exception of several walk-up apartment buildings, the building heights range from 8.4 m to 9.6 m. The parking types are, however, quite diverse. They include street parking, indoor front garages, a rear parking structure with shared driveway between buildings, and indoor parking with a side entrance.

The exterior building coverage in the district consists of three main masonry materials: brick, stucco and stone. It provides the neighborhood an old-fashioned flavour that helped preserve the unique character of NDG and the Benny Farm area. The majority of the buildings also sport porches and balconies that extend approximately 2 m from the main structure.

The roofs are primarily flat with very distinctive gables and parapets. The articulation of the building tops also lends the neighborhood a unique character. Most of the homes also have a chimney—on the building side.

The windows and doors in the area surrounding the site have a unique pattern. The windows are mostly verticle with a 2 to 1 ratio. Although many of the original doors were replaced with new ones, one can still spot many doors with unique stained glass patterns.

After documenting the key architectural features, the study offered a synthesis of what the most important features to consider are in the areas of typology, height, setback, parking, exterior walls, windows, doors and roofs. We considered most of these aspects in the units' design phase.

## Cost-reduction Stratagies

P.14

There are several cost-reduction strategies, not all of which are applicable to any one location. Some depend on locally accepted traditions of building and others on what the builders believe the market will be receptive to. When potential cost reduction strategies were listed for the Benny Farm area, we undertook a similar process of identifying those most relevant measures that can bring costs down significantly and, at the same time, be acceptable by Montreal builders and buyers. Some of these measures were considered "macro". They targeted the entire building and its surroundings. Other measures were considered "micro", since they investigated the dwelling interior and the building sub-components.

Under the "macro" banner we looked at a Volumetric Arrangement. There, the study examined the ramification of moving from single-family homes to duplexes (two family unit), triplexes (three family unit) and walk-up apartments. As one gradually increases density, the cost of land and infrastructure per unit declines. The cost fo the units also declines since the units are sharing the same foundation and services. The question still remains as to what will be acceptable by the buyers.

Examining the effect of the unit's width on cost was another issue examined. We looked at a range of applicable widths to the Benny Farm project and we selected 4.2 m, 4.8 m, 5.4 m and 6.0 m wide units. It was clear that as the units get wider, the cost of land, infrastructure and construction rise. The narrower the unit is, therefore, the most economic it will be.

The way the units are grouped (or joined) affects the cost was the next item studied. The number of joined units will affect both the cost and the appearance of a project. A long row will save on the margin of land between blocks of units and the cost of constructing end walls. Yet, having too many units in a row will have less of an architectural appeal and risk repetition and monotony.

We also examined the possibility of combining structures of different widths. The vernacular housing culture of Montreal has witnessed over the years the construction of duplexes next to triplexes and at times single family units. We looked at the possibility of recreating this in a new project. We studied combinations of types and widths. Here, too, when more units are constructed on the same block, lowered costs are evident. There is, however, reluctance on the part of developers to join different types of units since introducing different price scales in the same block will render the project difficult to market.

Parking solutions constitute one of the main challenges in affordable housing projects. Since in order to make efficient use of land the density has to be increased, more cars need to be accommodated. The other choice has to be between indoor and outdoor parking. Indoor conventional private parking garages will constitute \$23,410 of the cost of a dwelling unit. Construction of private outdoor garages is as expensive and requires ongoing maintenance. The price begins to decline once cars can be parked in common, either indoors or outdoors. Outdoor parking in common will be the least expensive, yet it is not visually appealing. Attention therefore must be paid to the location and the proper arrangement of the parking with the entire planning assembly.

Ground Relation was another consideration when we examined cost reduction strategies. Building a dwelling with a basement or without is a decision that can add to or reduce building cost. Here, too, the culture of building plays a role. In Montreal, livable basements are acceptable. There will be an addition to building cost, but the return will be in the form of useable space. Livable basements give a bad image to the project, however, and in affordable housing projects are at times even being avoided.

The roofscape can also contribute and influence affordability. Here, too, a choice has to be made between short term cost reduction and long term economic return on investment. Flat roofs will be the cheapest to construct (\$76.32/m<sup>2</sup>). They also fit with the architectural character of the new buildings in the Benny Farm redevelopment project. Pitched roofs build of prefabricated trusses will cost more (\$86.65/m<sup>2</sup>). The cost of pitched roof with an attic will be the highest (\$146.5/m<sup>2</sup>) yet it has the potential to yield the greatest return on monetary investment. The problem is an outlay of money at purchase time. This cost can be reduced if an attic is designed and left unfinished for the homebuyer to complete when means become available. It is a valid alternative that merits consideration at the outset of a project. It can also help create highly desired and affordable duplexes and triplexes.

The unit interior completion holds significant potential for cost savings. Savings in affordable housing is achieved by marginal contributions from a variety of aspects. The finishing of a home can constitute a significant amount of the cost and is therefore worth examining. We looked at unfinished basements (fairly common in Montreal), unfinished second floors, unfinished attics and leaving both the basement and the second floor incomplete. The last option has the potential to save some 13.02% of the overall construction cost.

Choice of number and location of wet services can also constitutes an important cost reduction strategy. The cost of a fully equipped and completed bathroom can range from \$4,500 to \$10,000 depending on the choice of fixtures. As a cost reduction measure, only one bathroom can be provided per home. Alternatively, preparation can be made for future installation of other bathrooms. Plumbing connections can be prepared and the house can be completed at a later date. The choice of finishing is another aspect that can affect cost. Fully tiled bathrooms (floor and walls) will be more costly. The cost will also be affected by the choice of bathroom fixtures.

The location of all the wet services in the house will also affect cost. Savings can be made by creating a "wet area" and by stacking all the different floor's bathrooms on top of each other. These measures can contribute to the overall cost reduction of an entire dwelling unit.

The choice of façade coverage material has a significant effect on the cost of a building structure. Some materials, like brick or stone, are not only expensive, but have labour-intensive and costly installation. Other materials, like wood or vinyl siding are less expensive, yet they have a "poor image" and will require long-term maintenance. In the Benny Farm project there is also the issue of fitting with the architectural character of the surrounding buildings. The common façade material in the area is brick, and using such a material in the future will be mandatory. The use of masonry is also required according to zoning. One therefore needs to consider the use of a mix of siding and brick with the latter constituting the majority.

Having a balcony or a deck can also influence cost. Balconies are part of the Montreal and NDG dwelling culture and they are commonly featured in the design of façades. Their number, however, can be limited. The builder may consider offering a first or second floor front balcony, or alternatively a deck. Decisions as to what to offer will depend on the overall cost target. Options can also be offered to buyers as part of a menu of offerings.

The approach to the design of the units' interior layout will also affect cost. Socio-demographic changes and the rise of the small household have made the open plan trendy. Reducing the amount of walls, which also carry wiring and other utilities and in which doors are installed, can lead to substantial savings. Options of interior layouts can be offer to buyers during the marketing phase. The offering will ensure a fit between design, household composition and cost.

A similar approach can be taken to the offering of kitchen bathrooms, laundry rooms, and storage. These functions constitute part of the finishing and therefore are relatively expensive. Choices therefore need to be given as to the functional layout and to the materials used. In the past few years we have also witnessed an expansion of renovation centers. Components are being designed and sold for installation by a layperson. Therefore, the "Grow Home" strategy can also be explored in the design of these functions. Storage elements are now being sold as packages, and they can be installed by the homebuyer or the manufacturer at a later date.

The type of flooring will also affect cost. Tiles will be the most expensive, linoleum or carpet the least. A cost reduction strategy will be to install a good product at first and have it replaced with another more expensive material at a later date. A similar approach can be taken with the finishing of the walls in the kitchen, bathroom and laundry room. The rooms can be painted at first and tiled at a later date.

Landscaping can provide another cost reduction opportunity. It is common in an affordable housing project to leave the backyard unlandscaped and not fenced. A similar approach can be taken in this project. Since the project will likely be sold as a condominium, several homeowners can get together and engage one contractor. They are likely to get a better price for the landscaping and fencing of their backyards.

The choice of a heating system will also influence the cost. The most economic system is with electric baseboards. Other systems will require the installation of ducts or pipes which make them highly expensive. The choice is often between economy and comfort. A recommended strategy in affordable housing is nonetheless not to save on designs that compromise energy efficiency and select good wall composition and good quality windows.

The type of chosen construction methods is also critical as far as cost is concerned. Conventional construction was considered, until recently, to be less expensive than prefabrication. Technical innovation, the use of power tools and automation are making prefabrication more competitive. The prefabrication of the entire structure or a part of it, therefore, needs to be considered at the outset. There is no doubt that by using prefabrication, time can be saved and quality increased.

Approach to the marketing of the units can also affect cost. The homes can be sold as "a package" or as a menu of offerings. The latter will be highly recommended in this project because it can ensure a better fit between buyers' socio-demographic background, their budget, and their chosen lifestyle.

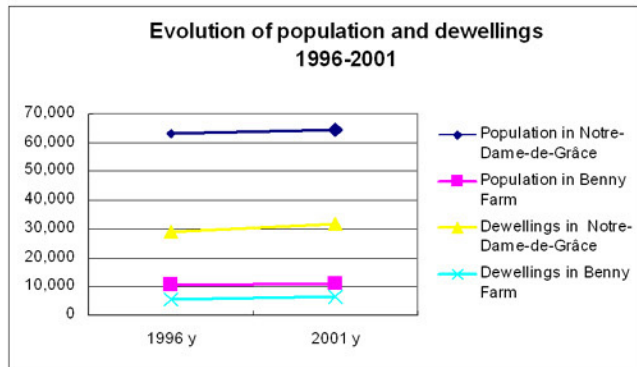

Source: Statistics Canada 1996 Census

Between 1996 and 2001, the population level increased by 2.7% in NDG, and 4.7% in the Benny Farm area. The dwelling level increased 9.6% in NDG, and 13.6% in Benny Farm area.

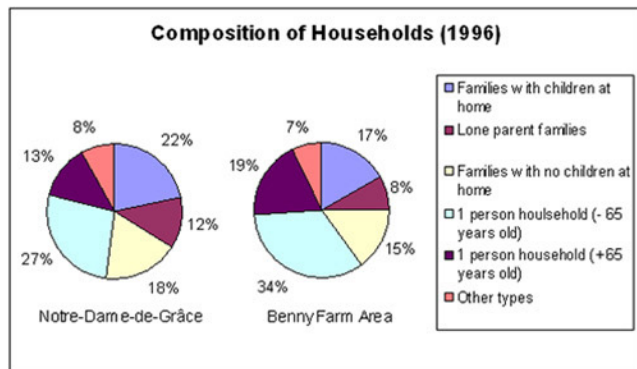

Source: Statistics Canada 1996 Census

The household composition denotes NDG is a neighborhood with a balance between family household and single household.

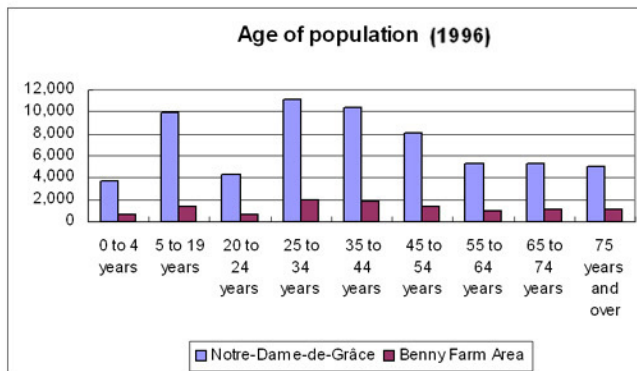

Source: Statistics Canada 1996 Census

The age graphic denotes that in NDG and Benny Farm area, the largest age groups are the 25-44 groups.

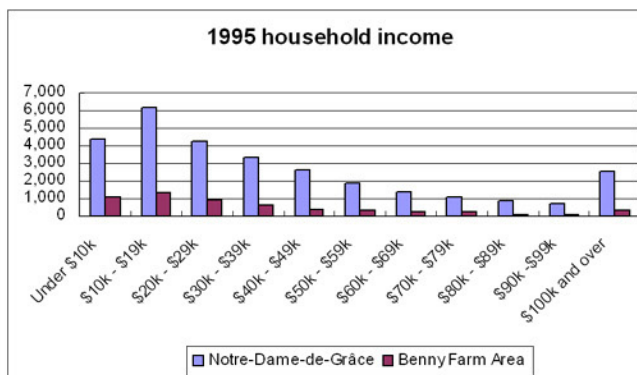

Source: Statistics Canada 1996 Census

In 1996, average household income in NDG was \$43,000, and the median income was \$32,000; the average household income in Benny Farm area was \$34,000, and the median income was \$24,000.

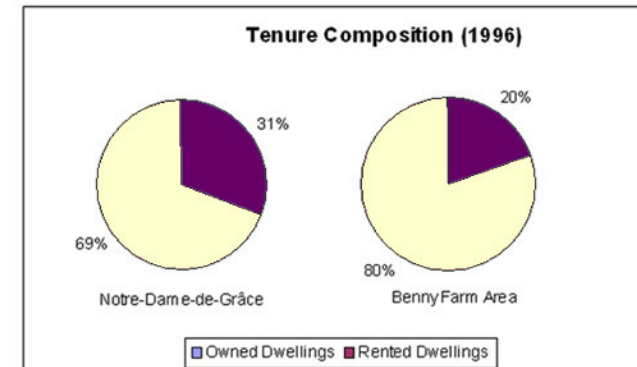

Source: Statistics Canada 1996 Census

The rental levels in NDG is 69%, which was outweigh the ownership levels (31%). In the Benny Farm area, renting is the dominant tenure, which is 80%.

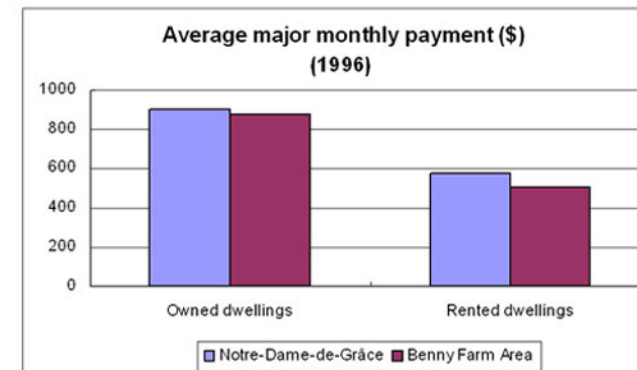

Source: Statistics Canada 1996 Census

In 1996, average major monthly payment for owned dwellings was \$903 in NDG and \$878 in Benny Farm area, and the average gross rent for rented dwellings was \$572 in NDG and \$508 in Benny Farm area.

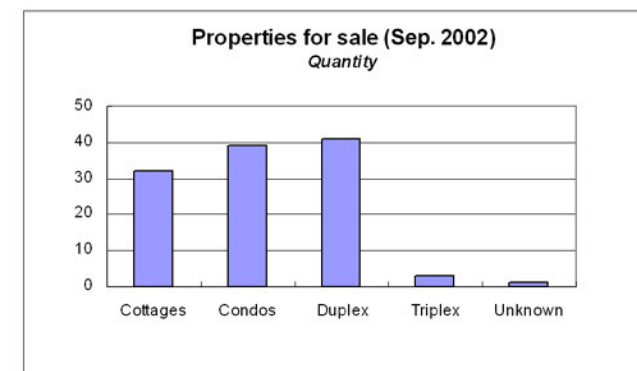

Source: Local and regional Newspaper ads, telephone and on site survey by CIRQ from September 10 to September 25, 2002

According to the survey by CIRQ from September 10 to September 25, 2002, the average price of cottages was \$384,416, the average price of condos was \$200,727, the average price of Duplex was \$260,787, and the average price of a Triplex was \$239,300.



Source: MLS and on site survey by CIRQ from September 10 to September 25, 2002

According to the survey by CIRQ September 10 to September 25, 2002, the average price of apartment for rent was \$823.

Two key aspects of affordability :																																																																	
1	The amount that one can afford as a downpayment																																																																
2	The mortgage payments that one can comfortably carry while still enjoying life																																																																
Determining the mortgage payments (\$) :																																																																	
1	<p><b>A x 32% (GDSR) = B</b></p> <p><b>A : Gross Monthly Household Income</b> Before income taxes and deductions</p> <p><b>GDSR : Gross Debt Service Ratio</b> Typically, household expenses should not exceed 32% of one's gross household income, it is a lifestyle and debt comfort zone.</p> <p><b>B : Affordable Monthly Household Costs</b></p>																																																																
2	<p><b>B - C = D</b></p> <p><b>C : estimated Monthly Property Taxes, Heating Costs and 50% of Condominium Fees, where applicable</b></p> <p><b>D : Maximum Monthly Mortgage Payment</b></p>																																																																
3	<p><b>D / E x 1,000 = F</b></p> <p><b>E : Mortgage Payment Factor</b></p> <p><b>F : Total Mortgage one can afford</b></p> <p><b>Mortgage Payment Factor Table</b></p> <table border="1"> <thead> <tr> <th rowspan="2">Rate</th> <th colspan="4">Amortization Periods</th> </tr> <tr> <th>25 years</th> <th>20 years</th> <th>15 years</th> <th>10 years</th> </tr> </thead> <tbody> <tr><td>4.00%</td><td>5.260</td><td>6.024</td><td>7.380</td><td>10.108</td></tr> <tr><td>4.50%</td><td>5.535</td><td>6.304</td><td>7.629</td><td>10.344</td></tr> <tr><td>5.00%</td><td>5.816</td><td>6.571</td><td>7.881</td><td>10.581</td></tr> <tr><td>5.50%</td><td>6.104</td><td>6.844</td><td>8.138</td><td>10.822</td></tr> <tr><td>6.00%</td><td>6.398</td><td>7.122</td><td>8.399</td><td>11.065</td></tr> <tr><td>6.50%</td><td>6.698</td><td>7.405</td><td>8.664</td><td>11.311</td></tr> <tr><td>7.00%</td><td>7.004</td><td>7.693</td><td>8.932</td><td>11.559</td></tr> <tr><td>7.50%</td><td>7.316</td><td>7.986</td><td>9.205</td><td>11.810</td></tr> <tr><td>8.00%</td><td>7.632</td><td>8.284</td><td>9.482</td><td>12.064</td></tr> <tr><td>8.50%</td><td>7.954</td><td>8.586</td><td>9.762</td><td>12.320</td></tr> <tr><td>9.00%</td><td>8.280</td><td>8.892</td><td>10.045</td><td>12.579</td></tr> </tbody> </table> <p>Table shows the blended monthly payment factors per \$1,000 of loan</p> <p>Sources : CMHC &amp; CIBC</p>	Rate	Amortization Periods				25 years	20 years	15 years	10 years	4.00%	5.260	6.024	7.380	10.108	4.50%	5.535	6.304	7.629	10.344	5.00%	5.816	6.571	7.881	10.581	5.50%	6.104	6.844	8.138	10.822	6.00%	6.398	7.122	8.399	11.065	6.50%	6.698	7.405	8.664	11.311	7.00%	7.004	7.693	8.932	11.559	7.50%	7.316	7.986	9.205	11.810	8.00%	7.632	8.284	9.482	12.064	8.50%	7.954	8.586	9.762	12.320	9.00%	8.280	8.892	10.045	12.579
Rate	Amortization Periods																																																																
	25 years	20 years	15 years	10 years																																																													
4.00%	5.260	6.024	7.380	10.108																																																													
4.50%	5.535	6.304	7.629	10.344																																																													
5.00%	5.816	6.571	7.881	10.581																																																													
5.50%	6.104	6.844	8.138	10.822																																																													
6.00%	6.398	7.122	8.399	11.065																																																													
6.50%	6.698	7.405	8.664	11.311																																																													
7.00%	7.004	7.693	8.932	11.559																																																													
7.50%	7.316	7.986	9.205	11.810																																																													
8.00%	7.632	8.284	9.482	12.064																																																													
8.50%	7.954	8.586	9.762	12.320																																																													
9.00%	8.280	8.892	10.045	12.579																																																													

Finding : Income, Home Price And Downpayment					
$(A \times 32\% - C) / E \times 1,000 + G = H$ $C = H^* \times 1.9522 / 12 / 100 + H^* \times 0.1\% + J^{**} \times 50\%$ or $C = H \times 0.3\%$					
<p><b>G : Downpayment***</b></p> <p><b>H : Maximum House Price</b></p> <p><b>J : Condominium Fees</b></p>					
<p>* : Property Tax Rate is 1.9522 per \$100 valuation per year, assumed valuation = house price; Heating Cost is estimated at 0.1% that of the house price per month (source : CMHC).</p> <p>** : Condominiums charge monthly fees for common area maintenance, such as groundskeeping and carpet cleaning. The fees range widely depend on the type of structure but will probably be at least a few hundred dollars (source : CMHC). For the townhouses and plexs, condominium fee can be estimated at 0.04% that of the purchase price. For the walkups, 0.08%.</p> <p>*** : 5 % downpayment is the minimum request for purchasing a house; still, Zero downpayment is possible. For example, Scotia Bank's "Free Down Payment" is an affordable 5 or 7 years fixed rate mortgage where the bank will pay on the homebuyer's behalf, the 5% minimum down payment required for the home purchase. This offer is available to customers who take out a new Scotiabank mortgage insured through GE Capital Mortgage Insurance (GEMICO). The customers will be required to repay the pro-rated amount of the 5% downpayment received if their mortgages are paid out, assumed on early renewed before maturity.</p>					
Mortgage Ratios in Montreal Metropolitan Area (%)					
	2002				2003
	1st Qtr.	2nd Qtr.	3rd Qtr.	4nd Qtr.	1st Qtr.
<b>One-year term</b>	4.8	5.6	5.3	5.0	5.1
<b>Five-year term</b>	7.05	7.4	6.9	6.8	6.6
Sources : CMHC Regional Office, Jun. 3, 2003					
Instead of the traditional mortgage, Home Credit Line has lower APR and much flexibility.					

Table : Income, Home Price And Downpayment							
	Household Income (\$)	5% Down-payment (\$)	Maximum Home Price (\$)	10% Down-payment (\$)	Maximum Home Price (\$)	25% Down-payment (\$)	Maximum Home Price (\$)
Median (Benny Farm)	24,454	3,480	69,645	7,220	72,230	20,320	81,275
Assumed Buyer (low)	30,000	4,270	85,440	8,860	88,610	24,930	99,710
Median (NDG)	31,565	4,490	89,900	9,230	93,235	26,230	104,910
Average (Benny Farm)	33,819	4,820	96,320	9,990	99,890	28,100	112,400
Average (Montreal)	40,848	5,820	116,340	12,060	120,655	33,890	135,570
Average (NDG)	42,655	6,080	121,510	12,600	126,020	35,450	141,800
Assumed Buyer (high)	60,000	8,540	170,885	17,720	177,225	49,850	199,415

Source (household income - annual) : Statistics Canada, 1996

This table shows the affordable maximum home price. The figures are based on annual percentage rate (APR) of 6.5%, average property tax and heating costs in NDG, and a 32% Gross Debt Service Ratio (GDSR). For loans greater than 90% of the value of the home, a maximum home price of up to \$250,000 may apply, based upon the price levels in the community.

Expenses that may influence the Downpayment	
GST	7% purchase price x (1-36%)
QST	7.5% (purchase price + GST)x (1-36%)
Welcome tax	0.5% for the first \$50,000 valuation 1.0% for the valuation between \$50,000 and \$250,000 1.5% for the valuation over \$250,000
Home inspection fee	\$150 to \$ 350
Lawyer's fees	\$350 to \$2,500
Mortgage broker's fee	
Mortgage loan insurance application fee	\$75 to \$235
Appraisal fee	\$150 to \$250
Service hook-up fees	\$75 to \$235
Survey fee	\$75 to \$235
Water quality & quantity certificate	\$50 to \$100
Moving expenses	\$50 to \$100 per hour
Renovations/repairs	
Expenses that may influence the Monthly Payment	
House insurance	\$450 and up per year
Mortgage loan insurance premium*	0.5% to 3.75% of loan
School tax	0.35% valuation per year
Renovations/repairs	
* : Table of Insurance Premiums	
Loan size (percent of purchase price)	65* 75* 80* 85* 90* 95*
Premium (percent of loan)	0.50 0.75 1.25 2.00 2.50 3.75
* : Up to and including.	

Expenses listed here are those other than purchase price and mortgage (mortgage loan insurance premium can be included in the mortgage) that may or may not involved in buying or maintaining a home.	
GST : Goods and Services Tax, the rate is 7%. On new homes only. The 7% is almost without exception paid by the builder (source : E*TRADE Securities LLC and E*TRADE Canada Securities Corporation).	
QST : Quebec Sales Tax, the rate is 7.5%.	
QST rebate claimed further to a Gst rebate: The rebate for GST and QST is 36%. The maximum GST rebate of \$8,750 is granted where the purchase price or fair market value (FMV) of a newly constructed or substantially renovated home, together with the lot, is \$350,000 (not include GST). Where the purchase price is over \$350,000 but under \$450,000, the maximum rebate is progressively reduced. No GST rebate maybe claimed if the purchase price is \$450,000 or more.	
Home-owner intentions to renovate (Montreal): Ready to renovate: 24% Possible renovators: 6% Average spending for home-owners renovating (Montreal): \$7,485.	
Planned renovation expenditures (\$)	Percentage of renovators (%)
from \$1,000 to \$2,000	24
from \$2,001 to \$3,000	13
from \$3,001 to \$5,000	24
from \$5,001 to \$10,000	20
from \$10,001 to \$25,000	12
over \$25,001	7

Sources : CMHC



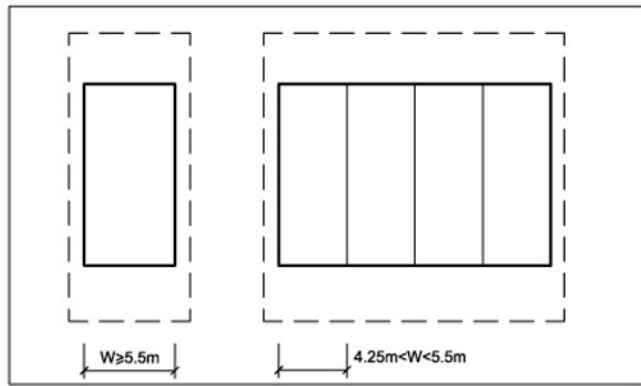

**Building Width**

Buildings with exclusively residential use must be at least 5.5 m wide.

Buildings with exclusively residential use may have a width of 4.25 m to 5.5 m if they are attached and if they are laid out on a lot less than 5.5 m wide.

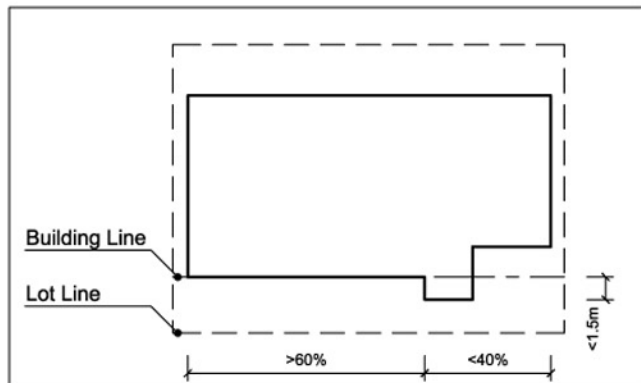

**Building Lines**

At least 60% of the façade area must be on the building line.

No more than 40% of the façade area may be laid out at one of the following places:  
 (1) set back from the building line;  
 (2) in front of the building line, the front part not projecting by more than 1.5 m.

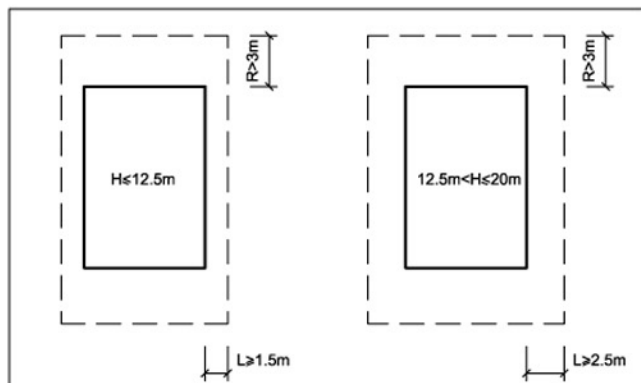

**Set Back**

H: Maximum Height  
 L: Minimum lateral set back  
 R: Minimum rear set back

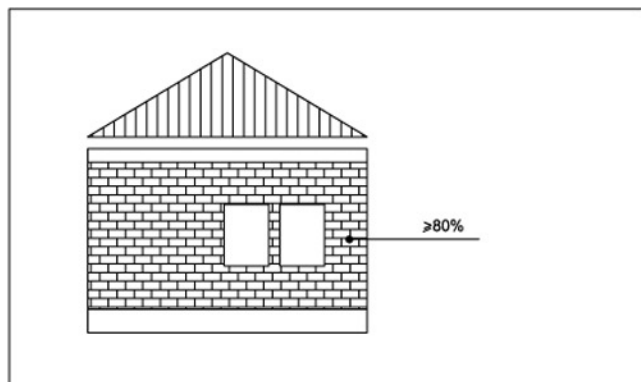

**Masonry**

A façade must be covered with masonry on at least 80% of its surface, excluding openings.

The new facing of a building façade must be similar to the existing facing where that facing is similar to that of the façade of the adjacent building erected up to the common side line.

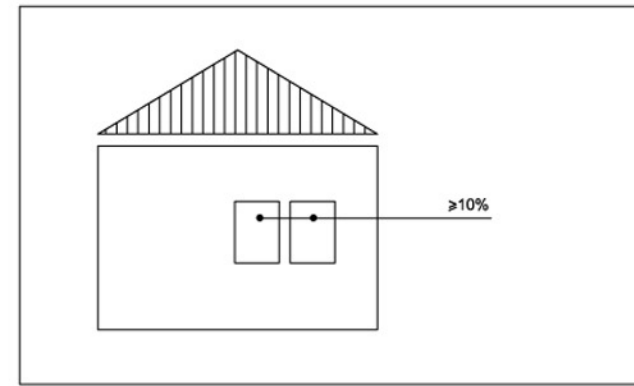

**Openings**

The area of openings must be 10% or more of:  
 (1) the area of the ground floor façade;  
 (2) the area of a façade.

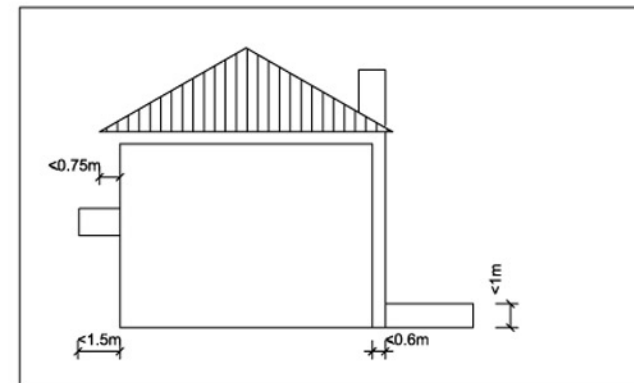

**Projections**

Projections as left are authorized in front of the façade plane nearest the public thoroughfare or its extension, as well as in lateral and rear setbacks:  
 a: Balcony  
 b: Terrace  
 c: Architectural and crowning elements such as cornices, false mansards, eaves, pilasters and columns.  
 d: Chimney

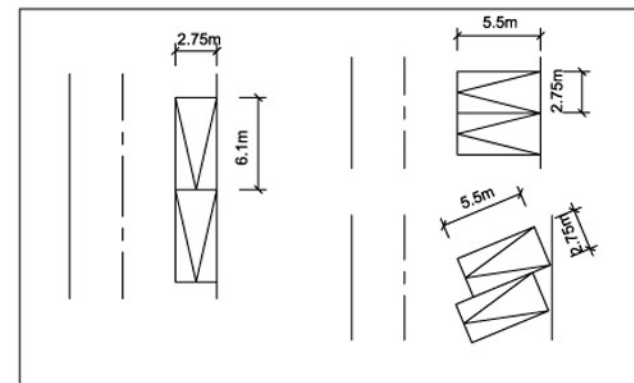

**Parking**

No parking unit may be:  
 (1) less than 2.75 m wide and 6.1 m long when it is parallel to a traffic lane, a lane or a public thoroughfare;  
 (2) less than 2.75 m wide and 5.5 m long in other cases.

Parking ratio for building containing more than 3 dwelling units:  
 (1) Total floor area less than 50 m<sup>2</sup> per dwelling unit  
 1/4 ~ 1/Unit  
 (2) Total floor area more than 50 m<sup>2</sup> per dwelling unit  
 1/3 ~ 1.5/Unit

Proposed Planning Index <sup>(2)</sup>					
Lot Area	(m <sup>2</sup> )	9492	Proposed Average Density for All Lots		1.5
Building Coverage	(m <sup>2</sup> )	3809	Proposed Average Building Coverage Ratio for All Lots	%	45
Building Coverage Ratio	%	40.1	Height	Storey	2-3
Total number of Units	Un.	87	Parking Ratio	/unit	1

Source:  
 1. Urban Planning By-law, City of Montreal, 1996-  
 2. Proposition de Plan D'ensemble de Benny Farm, 2003



Typology

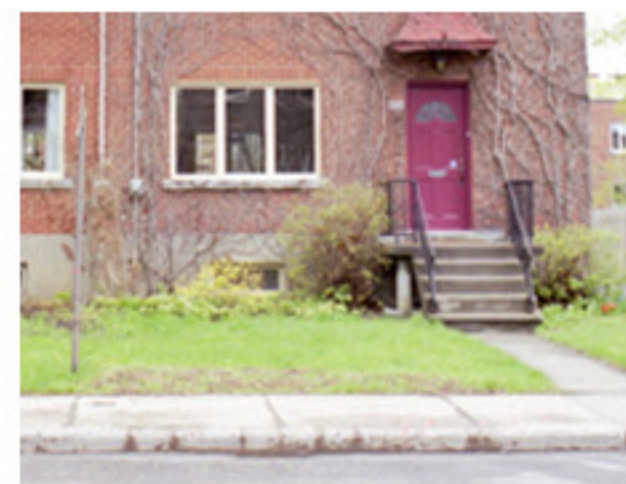

Setback



Parking



Height



PROPOSED SITE PLAN FOR BENNY FARM

SOURCE: SAIA et BARBARESE ARCHITECTS



Exterior Features



Roofs



Doors



Windows

**Typology**



Avenue Benny



Avenue Walkley



Avenue Monkland



Avenue Westhill

**Analysis**

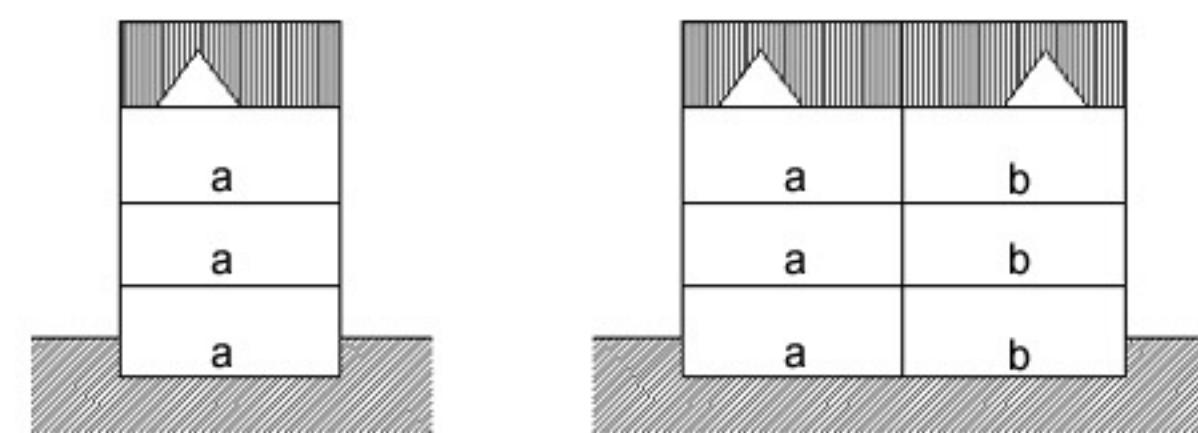
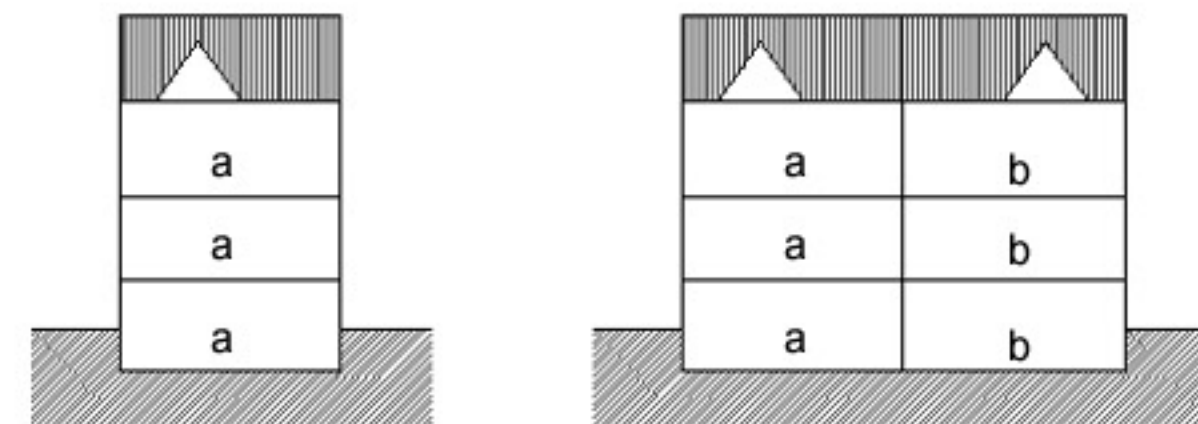
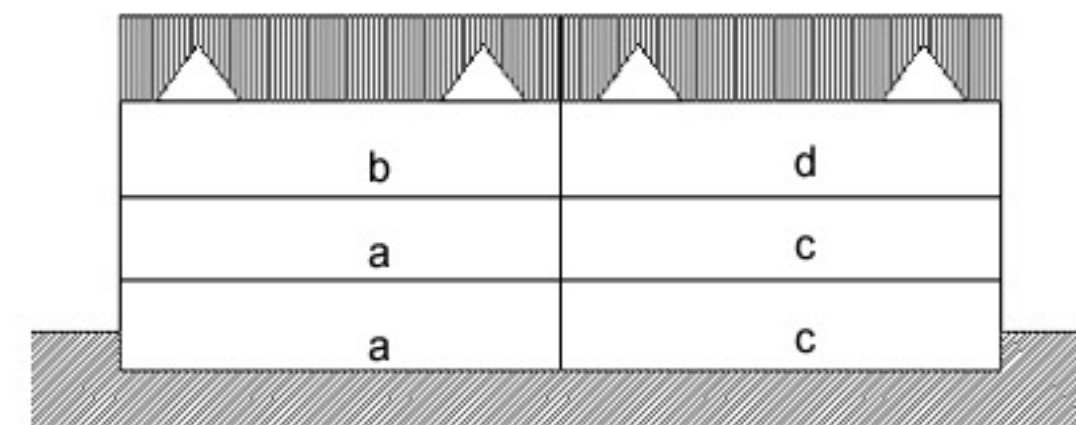
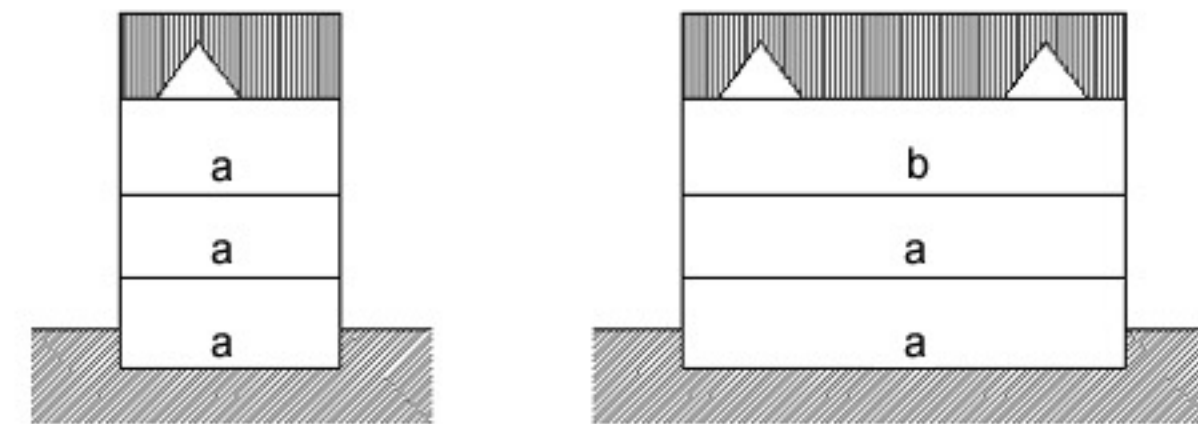
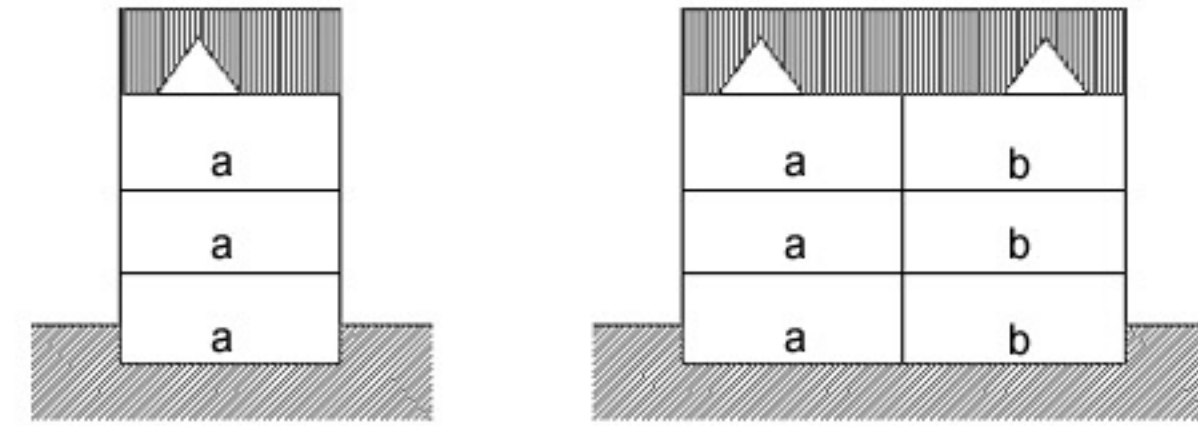

**Setbacks**



Avenue Benny



Avenue Walkley



Avenue Monkland



Avenue Westhill

**Analysis**

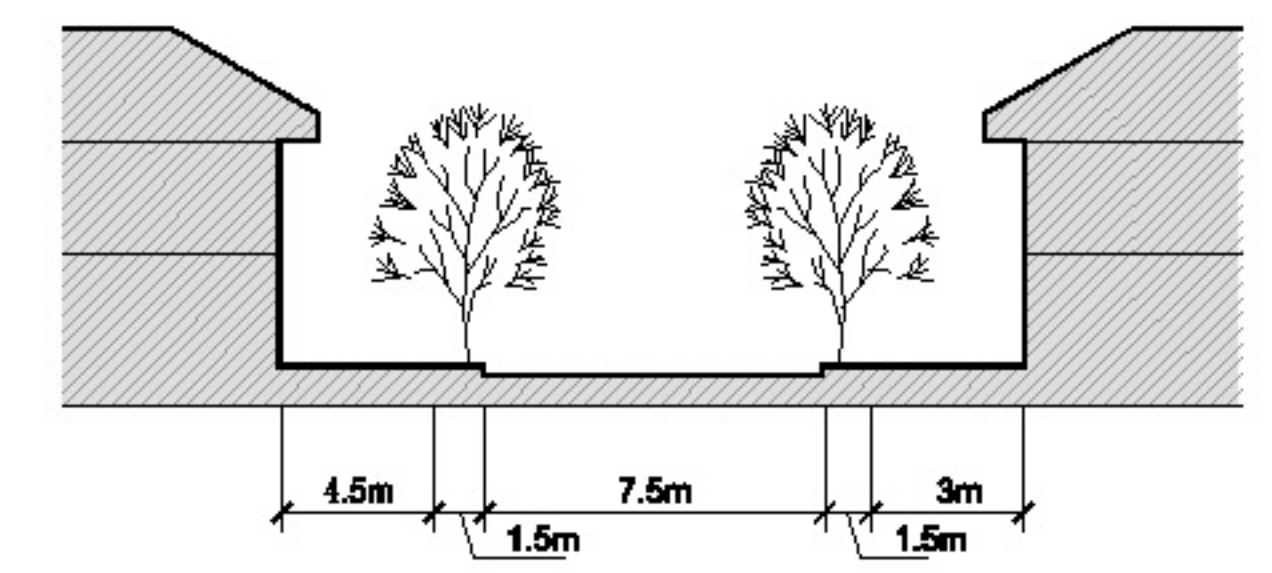
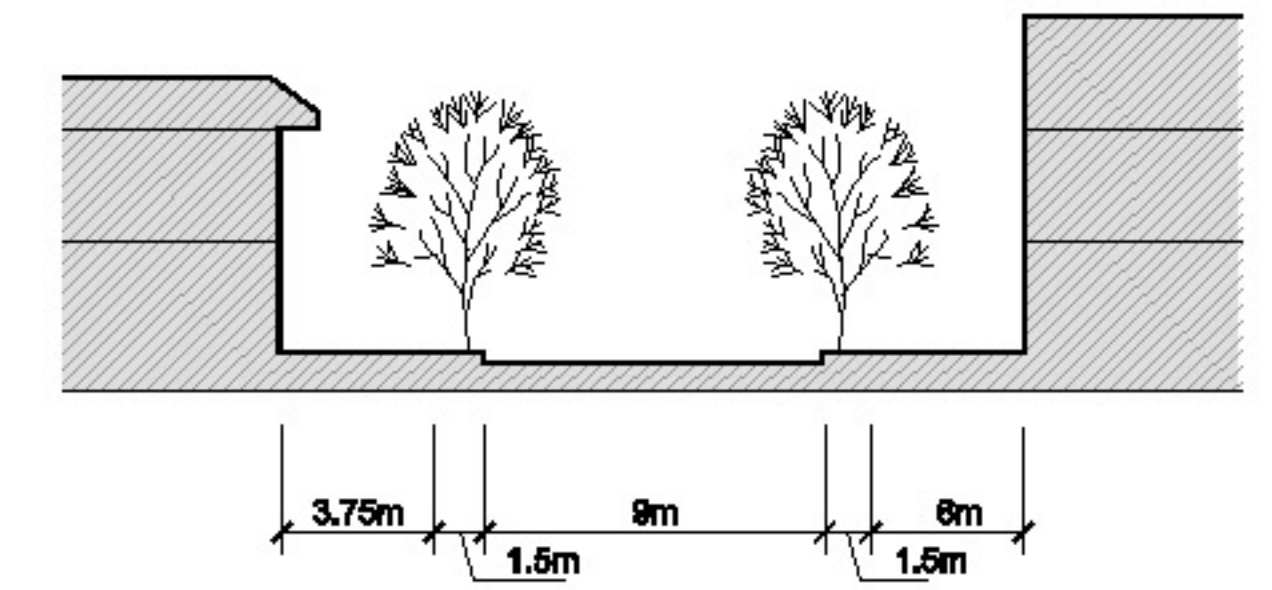
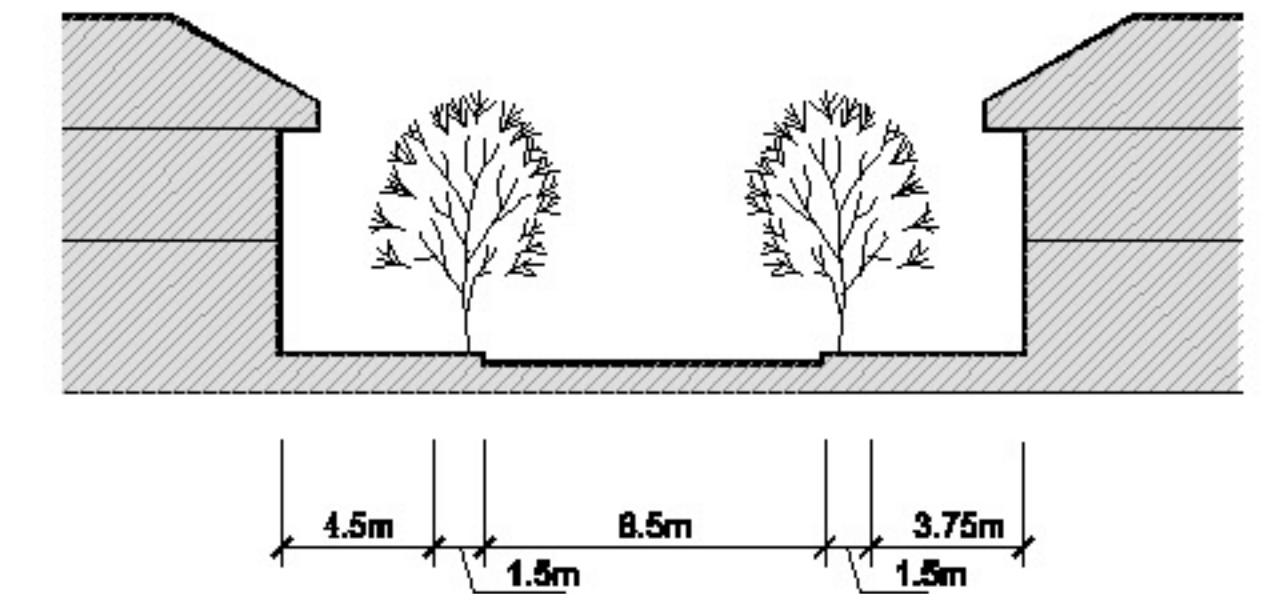
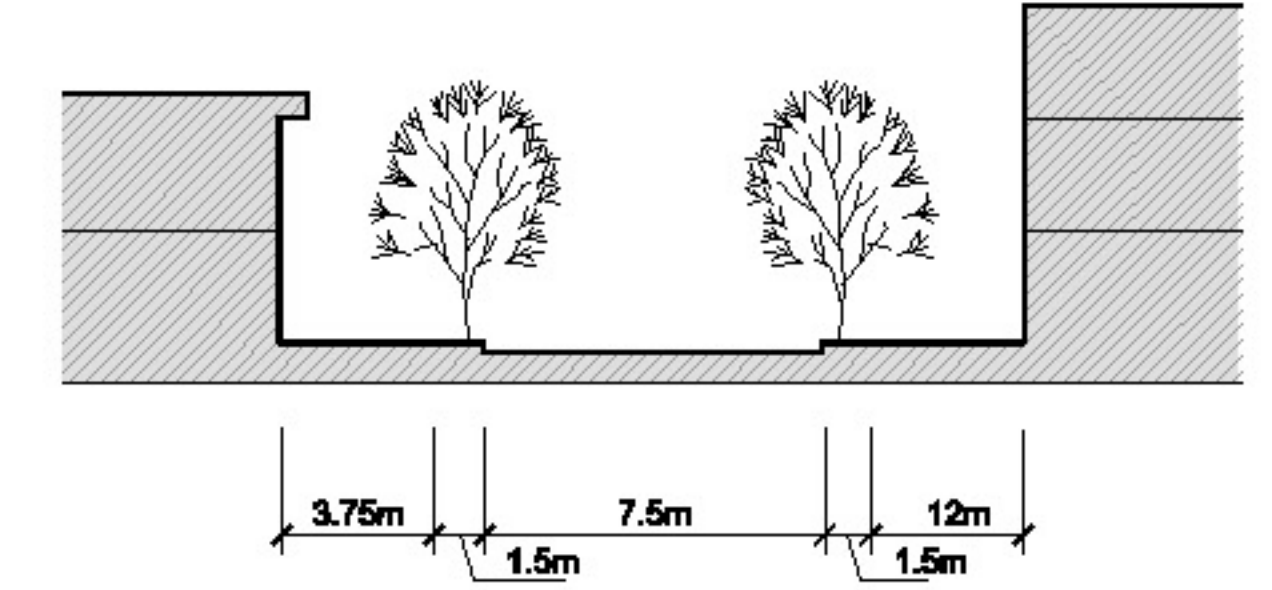

**Heights**



Avenue Benny



Avenue Walkley



Avenue Monkland



Avenue Westhill

**Analysis**

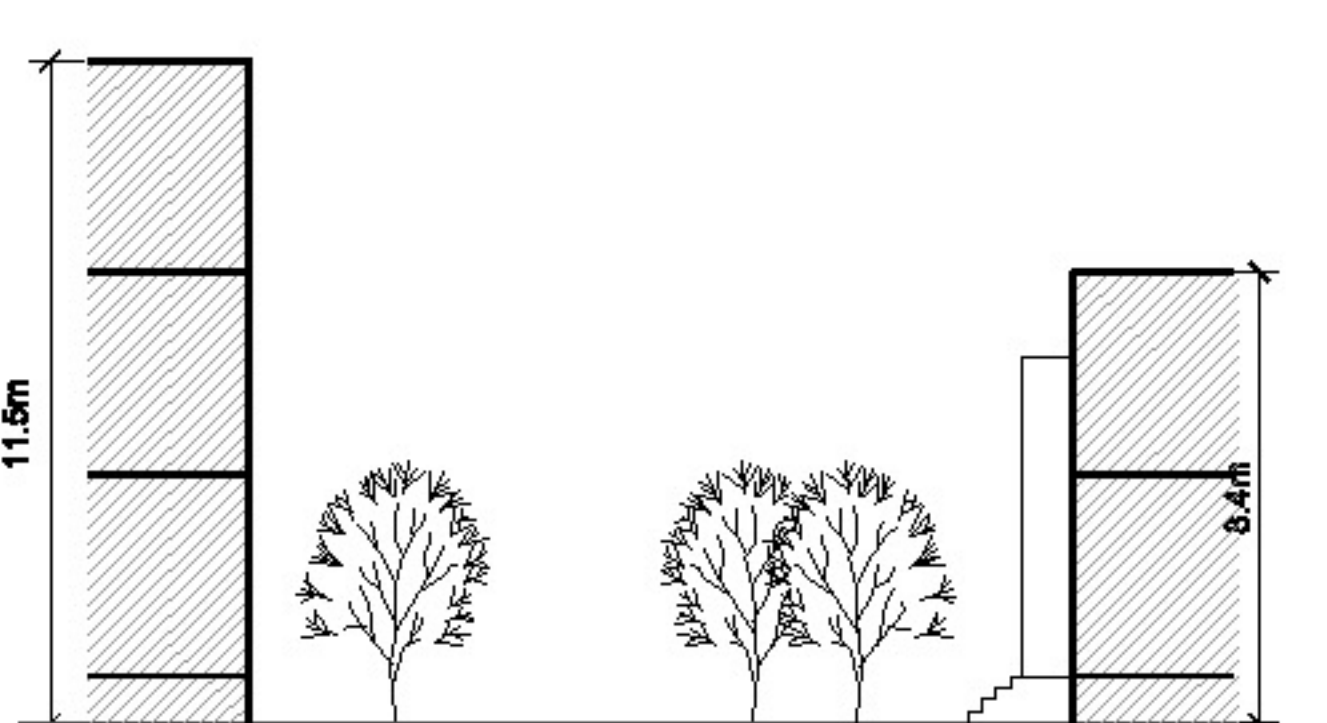

**Parking**



Avenue Benny



Avenue Walkley



Avenue Monkland



Avenue Westhill

**Analysis**

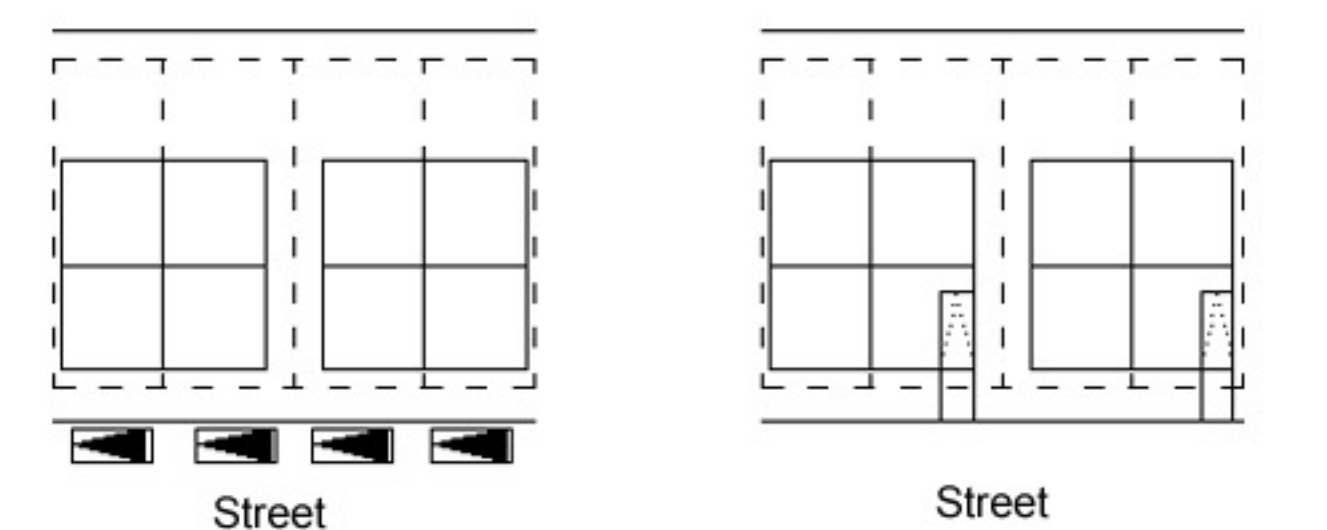
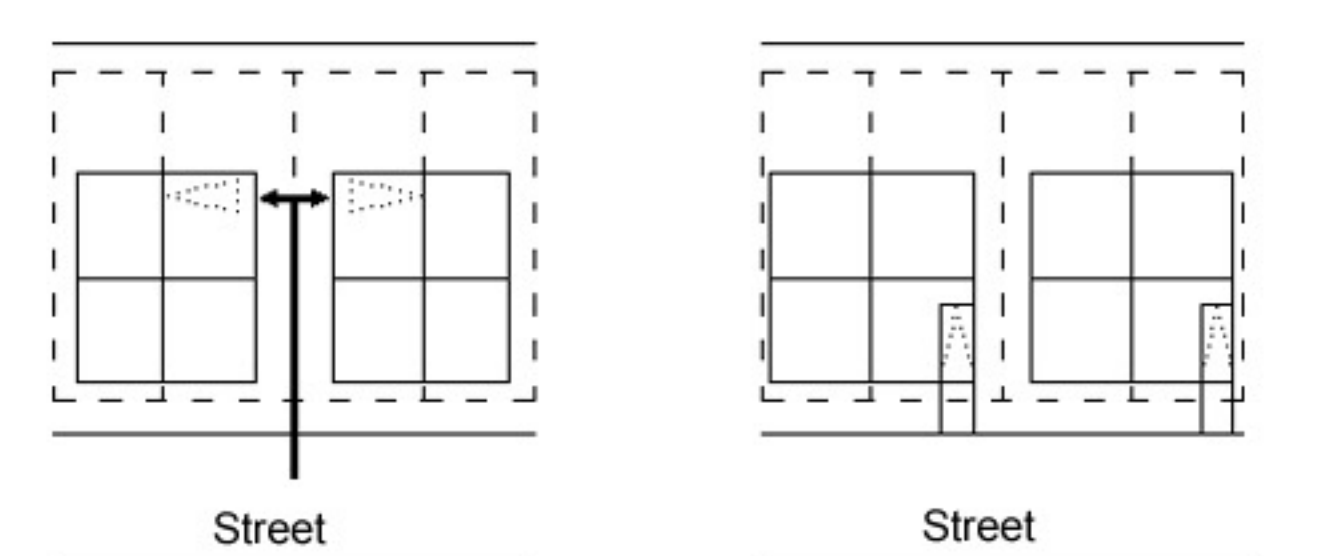
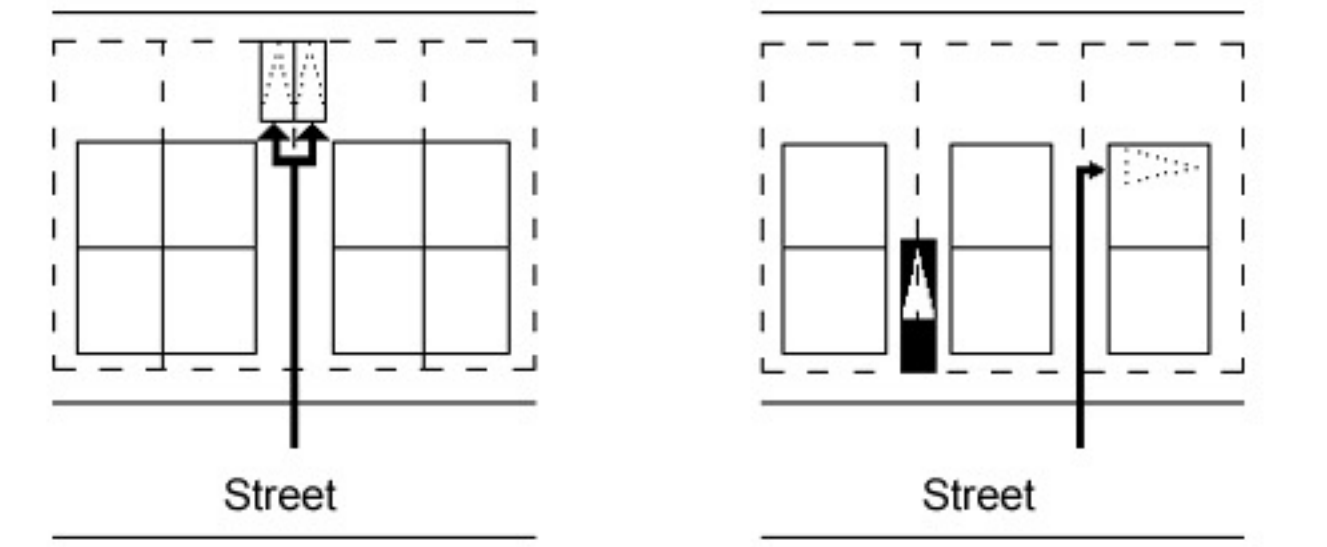
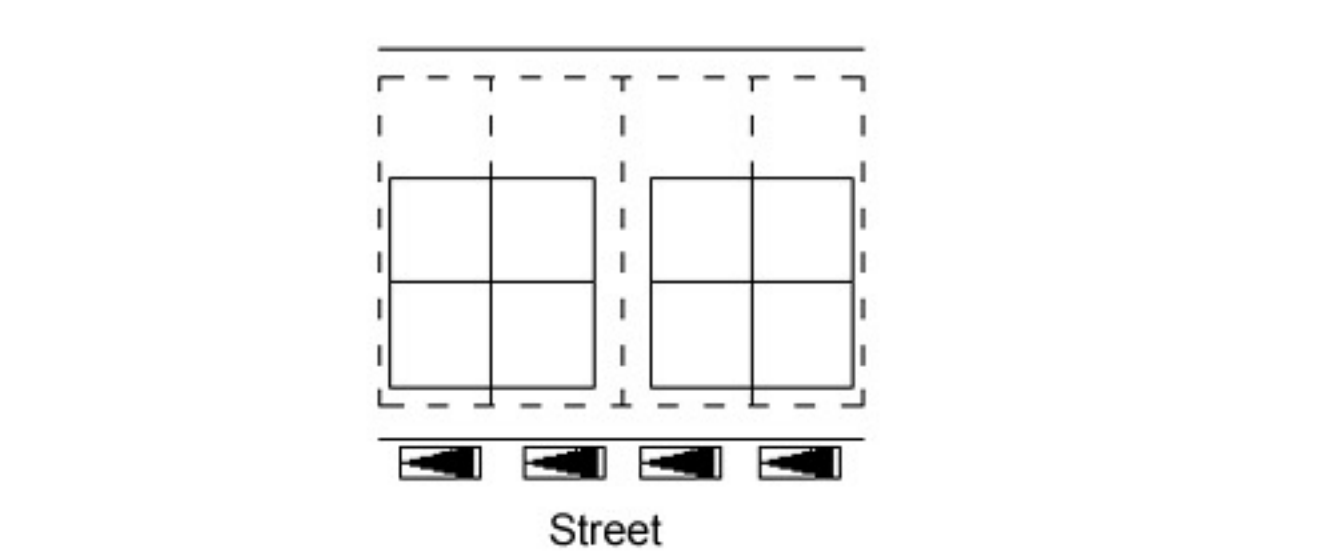
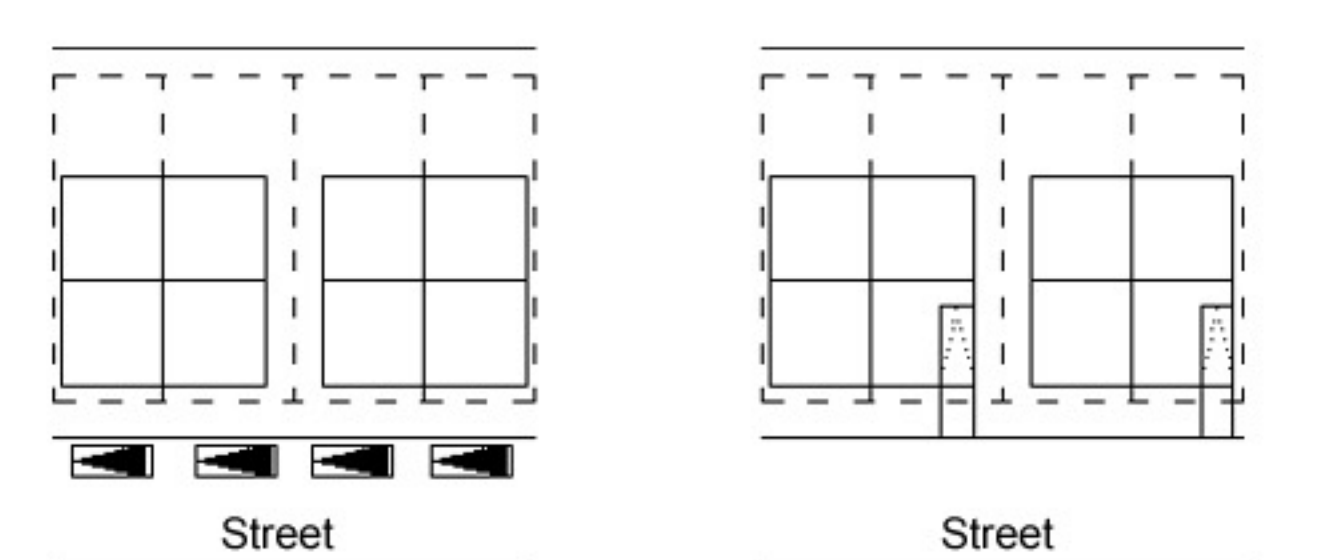

Exterior Features



Cladding Material



Portch / Balcony

Analysis

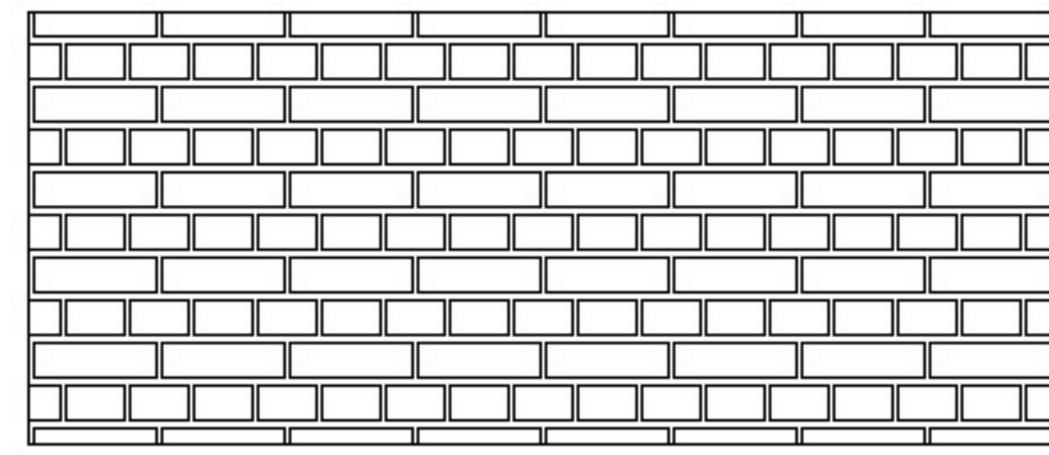

Brick

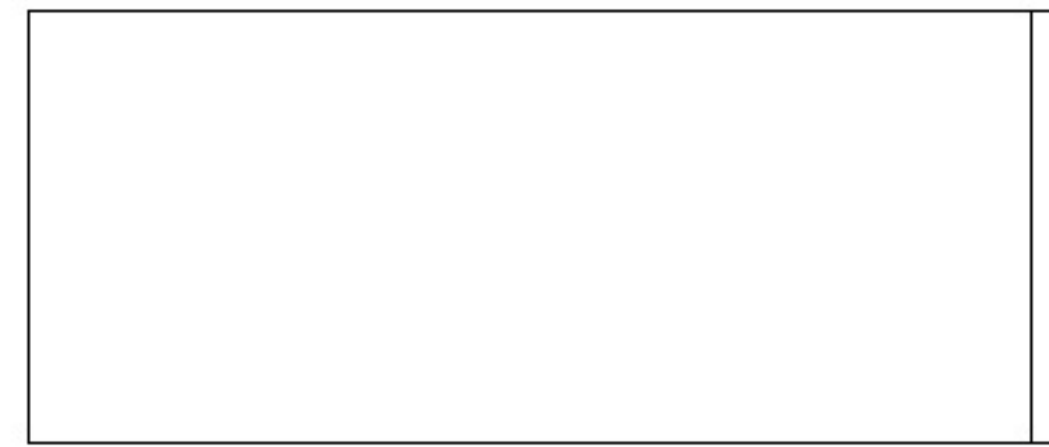

Stucco

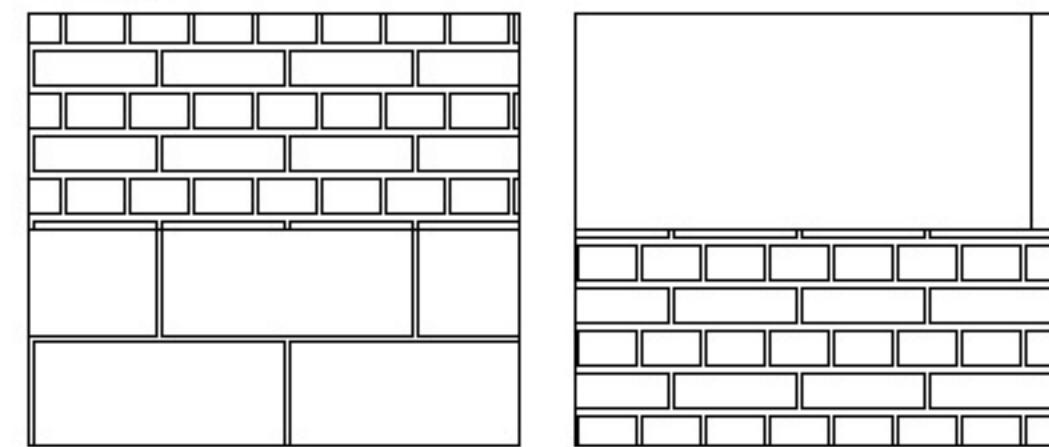

Brick and Stone

Stucco and Brick

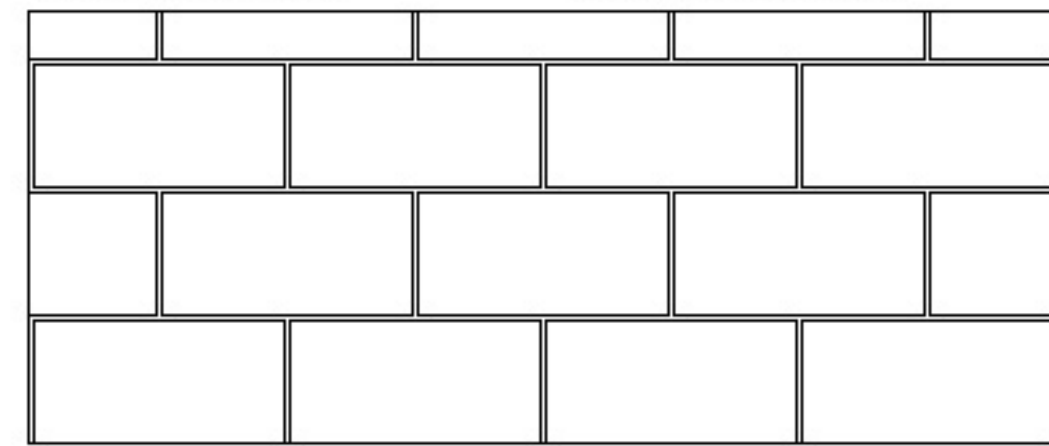

Stone

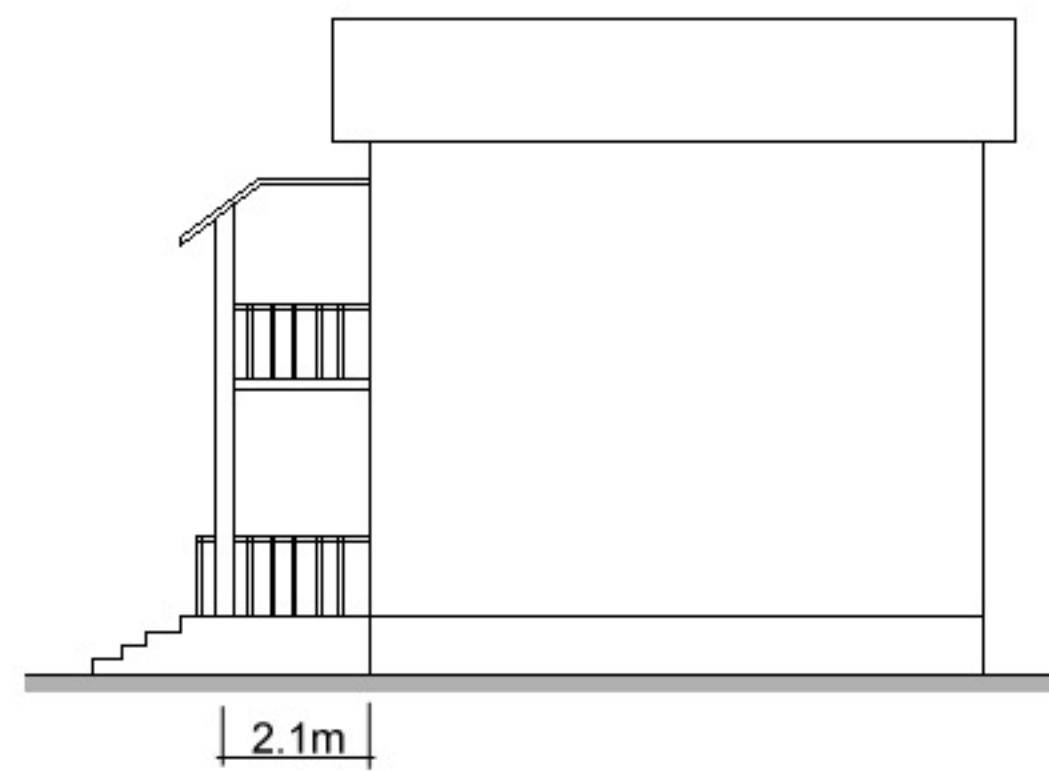

Roofs



Shape



Chimneys

Analysis

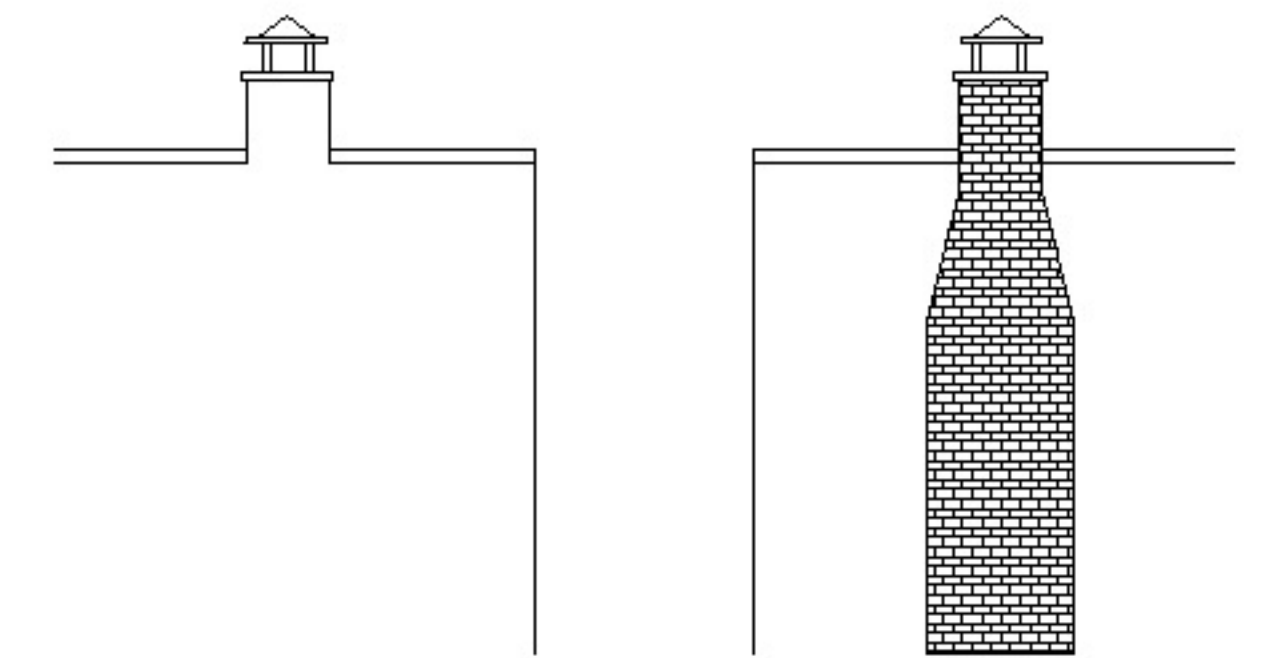
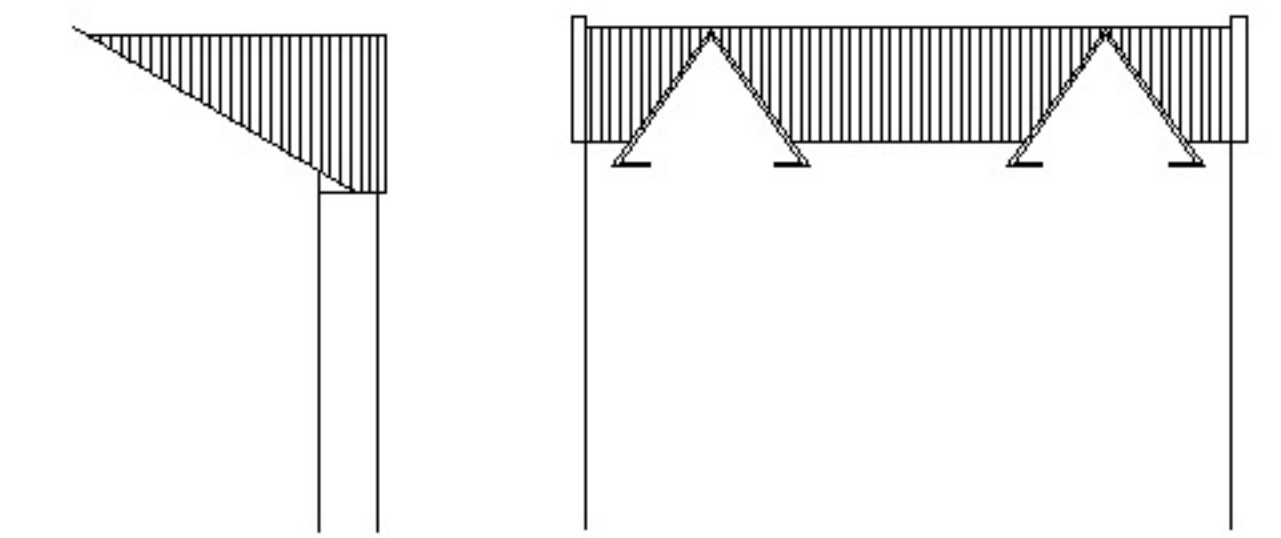
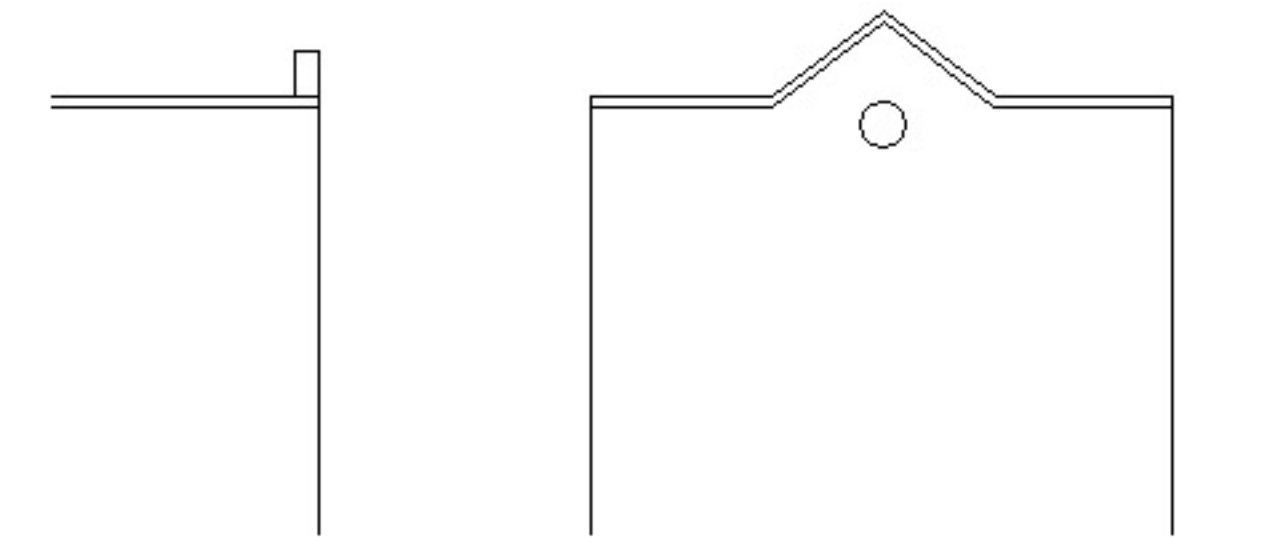
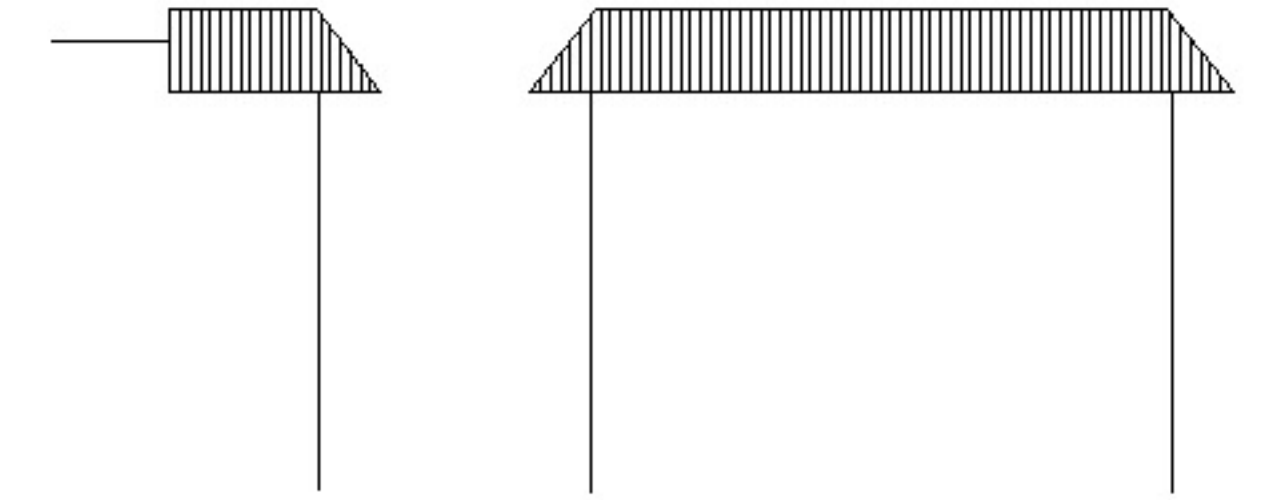

Windows



Type



Materials



Colour

Analysis

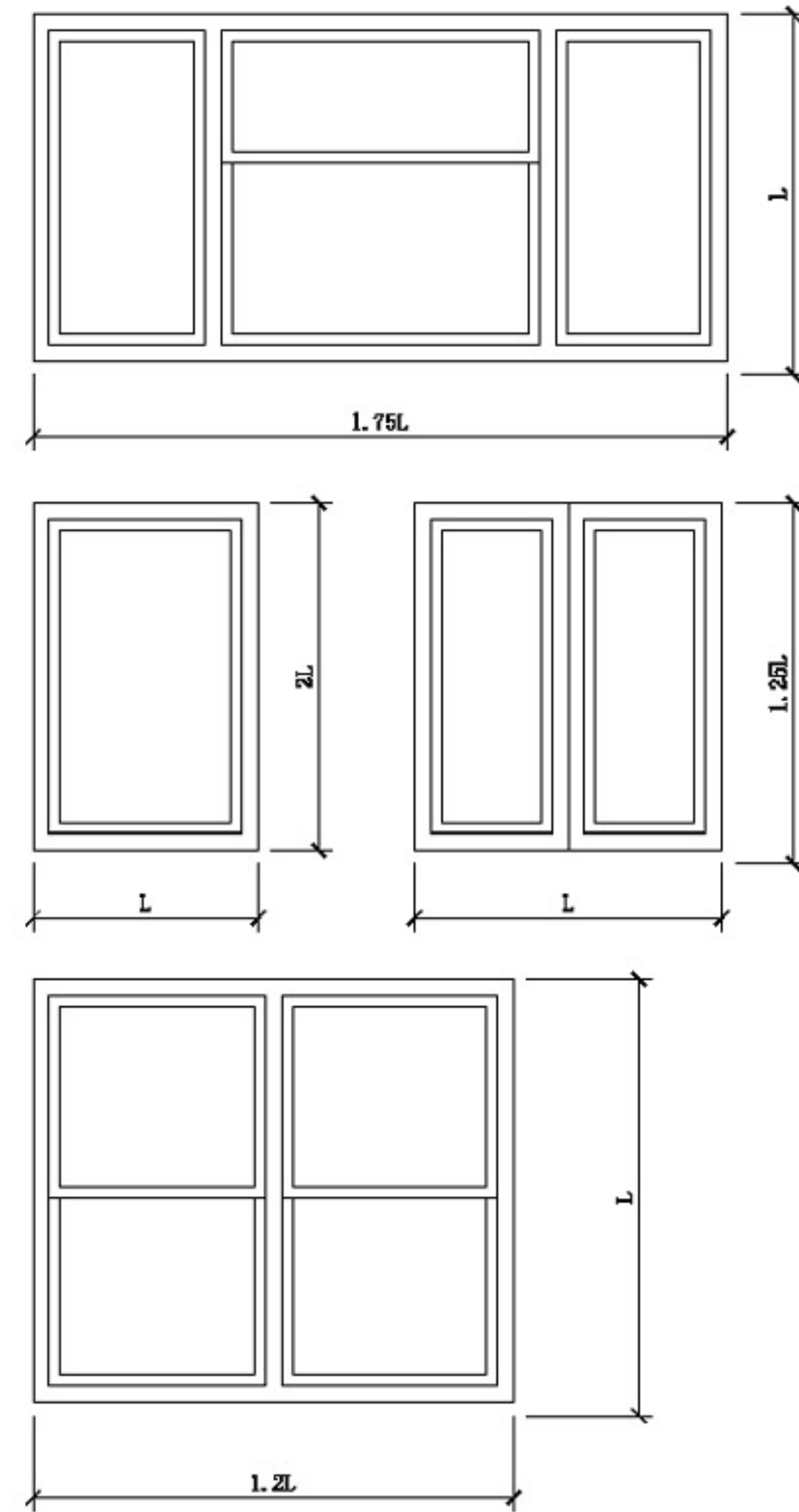

Doors



Type



Materials



Colour

Analysis

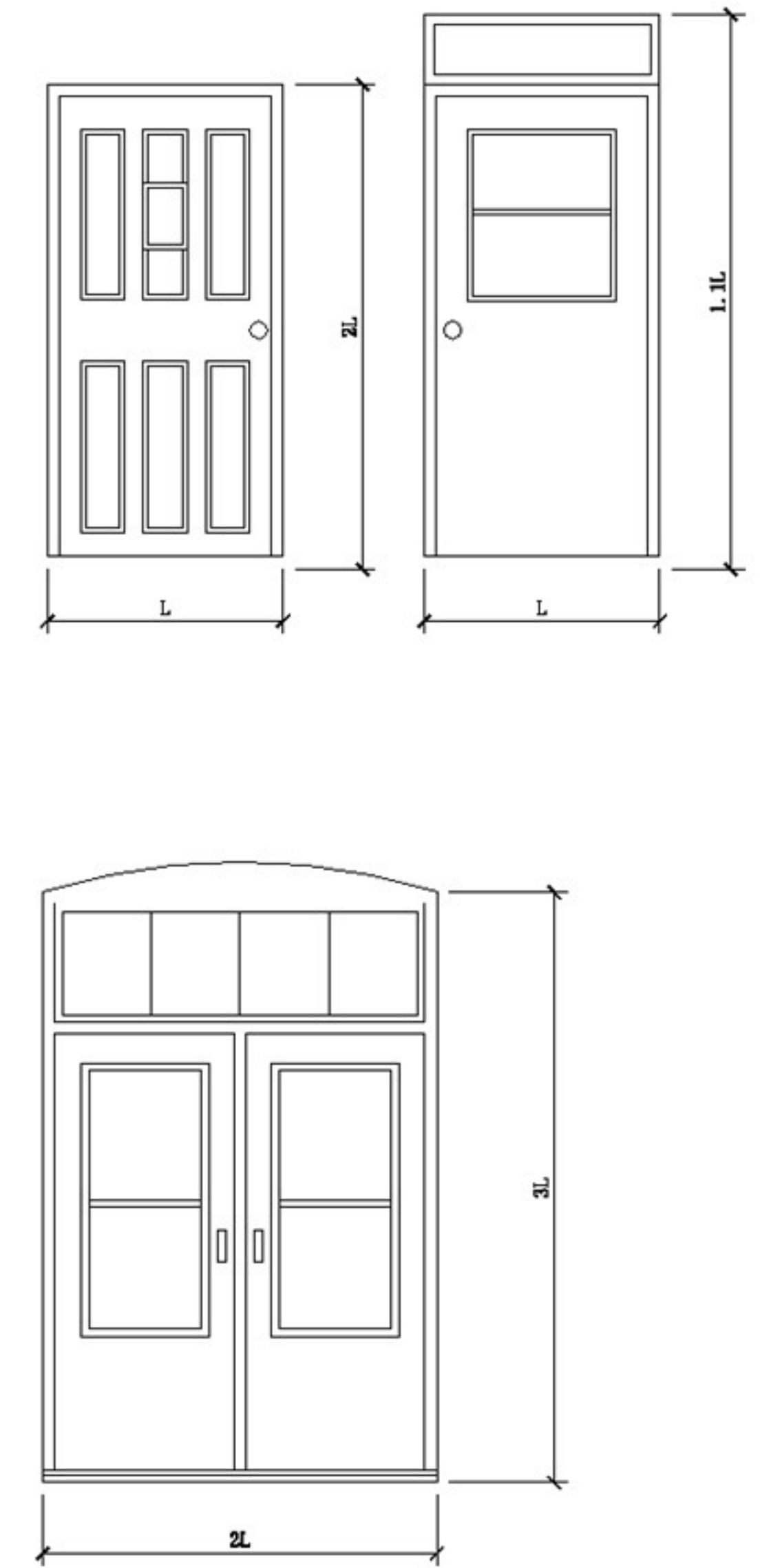

### Typology

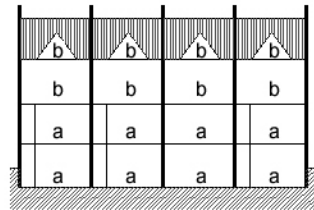
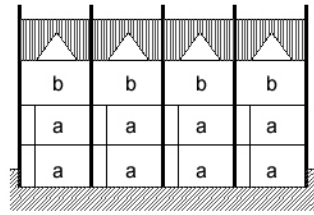

The proposed housing typology for the new project should be single family and multi-family housing in row.

### Setbacks

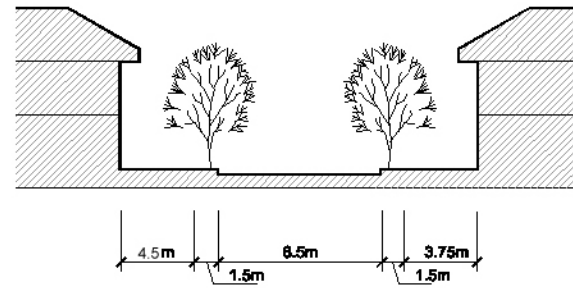

According to the existing setbacks in this area, the recommended setbacks range between 3.75m to 4.5m.

### Exterior Walls

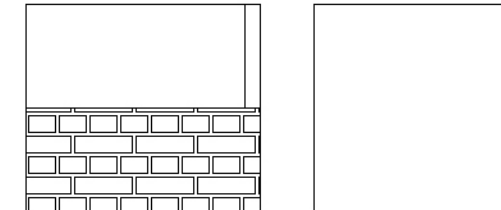
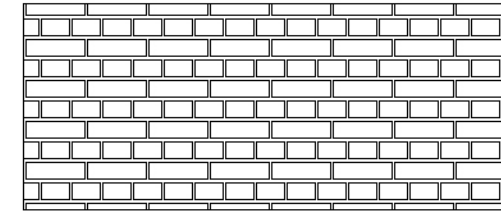

The most common cladding material for this area is brick, stucco and combination of both.

### Roofs

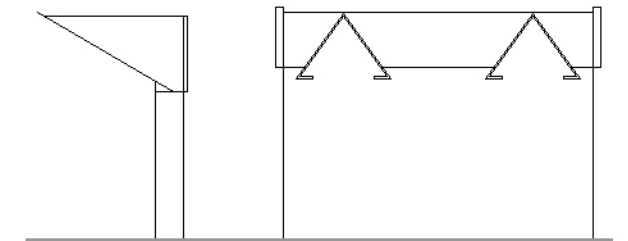
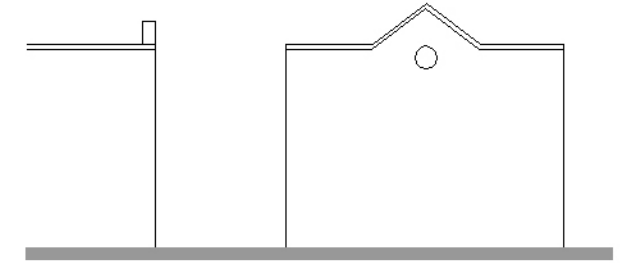

The common roof type in this area is either a flat roof, a simple gable or a combination of gables.

### Height

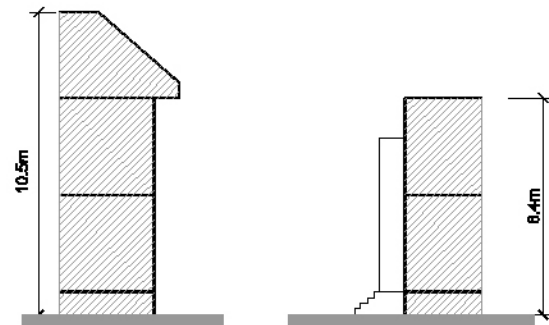

The recommended new housing heights are two storeys with a semi-basement and three storeys with slopped roof.

### Parking

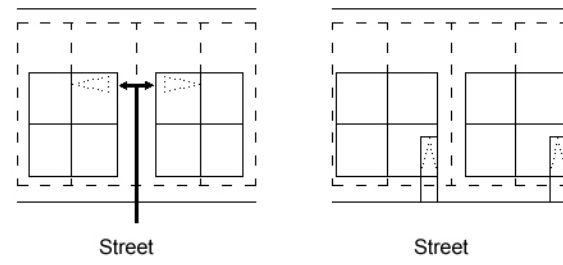
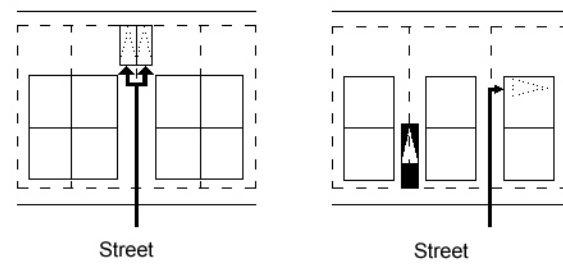

### Windows

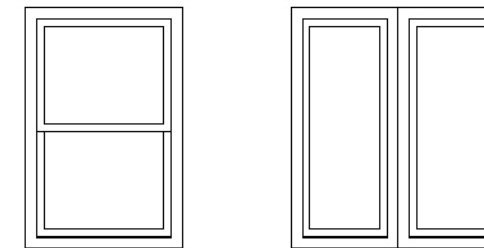

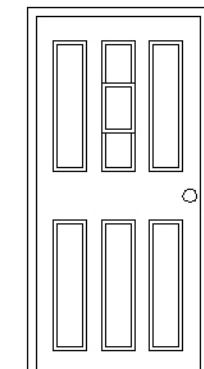

Fixed windows are usually flanked by two windows of another type such as casement, or double hung. As well, most of the houses have only one type of window. The preferred material for windows in this zone is wood. However, the material for some windows are vinyl.

### Doors

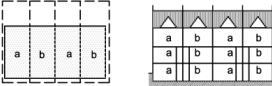
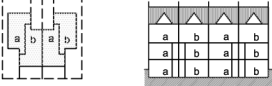
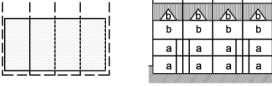
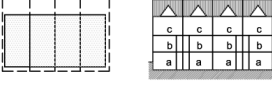

Doors made of wood may have more detail in the form of carving on the door. Wood may be a better choice of door material if more individuality is wanted and wooden door have more sense of cosy home.

**Volumetric Arrangements**

- V1** Single family (built in a row) 
- V2** Zipper lots 
- V3** Multi-family (duplexes) 
- V4** Multi-family (triplexes) 
- V5** Walkup apartment 



**Width**

- W1** Row 4.2 meter (single family)
- W2** Row 4.8 meter (single family)
- W3** Row 5.4 meter (single family)
- W4** Row 6.0 meter (single family)

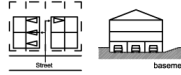
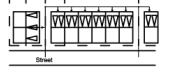
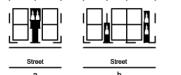
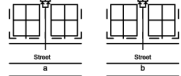

**Grouping**

- G1** Four units in a row
- G2** Six units in a row
- G3** Eight units in a row
- G4-1** Combination of types
- G4-2** Combination of types
- G5-1** Combination of widths
- G5-2** Combination of widths



**Parking**

- P1** Indoor access from the front 
- P2** Indoor side access 
- P3** Indoor back access 
- P4** Outdoor access from the front 
- P5** Outdoor front access with servitude between units 
- P6** Outdoor back access 

**Ground Relation**

- GR1** Units with slab on grade 
- GR2** Units with basement 

**Roof**

- R1** Flat Roof 
- R2** Pitched Roof 
- R3** Pitched Roof with an Attic 



**Interior Completion**

- I1** All Floors Finished
- I2** Unfinished Basement
- I3** Second Floor Unfinished
- I4** Unfinished Attic
- I5** Second Floor and Basement Unfinished





**Wet Service/Utilities**

- U1** Three Bathrooms
- U2** Fittings for Bathroom in the Basement
- U3** One Bathroom + Powder Room
- U4** One Bathroom
- U5** Separated Plumbing
- U6** Back to Back Plumbing



**Facade - Materials**

- Mt1** Siding 
- Mt2** Stucco 
- Mt3** Brick 



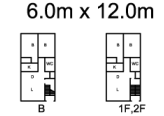

**Facade - Balconies**

- B1** No Balcony 
- B2** Back Only 
- B3** Front Only 
- B4** Front and Back 





**Interior Layout**

- L1** 4.2m x 12.0m 
- L2** 4.8m x 12.0m 
- L3** 5.4m x 12.0m 
- L4** 6.0m x 12.0m 





**Kitchen**

- K1** 
- K2** 
- K3** 
- K4** 







**Bathroom**

- B1** 
- B2** 
- B3** 
- B4** 





**Laundry**

- L1** 
- L2** 
- L3** 
- L4** 



**Storage**

- S1** 
- S2** 
- S3** 
- S4** 
- S5** 
- S6** 
- S7** 

**Flooring**

- F1** Carpet 
- F2** Linoleum 
- F3** Tiles 
- F4** Parquet 



**Cabinets**

- C1** Melamine 
- C2** Oak 



**Bathroom Walls**

- W1** Paint 
- W2** Tiles 



**Landscaping**

- Y1** No Grass 
- Y2** Grass 
- Y3** Deck 



**Heating System**

- H1** Electric 
- H2** Gas 
- H3** Oil 

**Cons. Techniques**

- CT1** Conventional 
- CT2** Prefabricated 

**Marketing Strategies**

- MS1** Offer Package 
- MS2** Menu 



## Volumetric Arrangements

### V1 Single family ( built in a row)

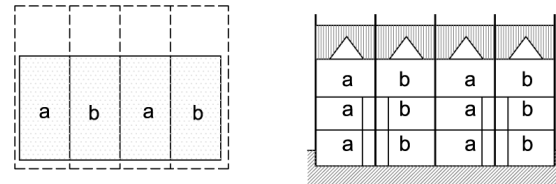

### V2 Zipper lots

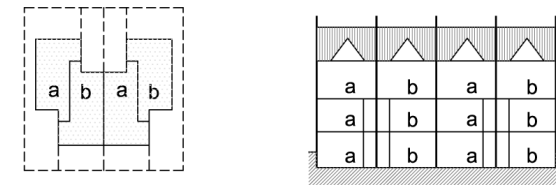

### V3 Multi-family ( duplexes)

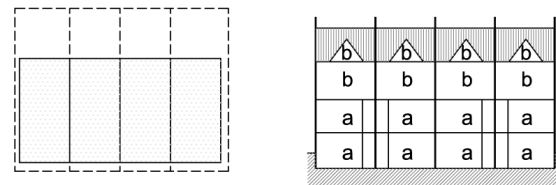

### V4 Multi-family ( triplexs)

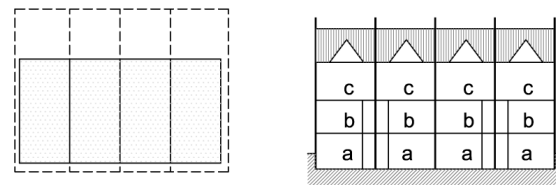

### V5 Walkup Apartment

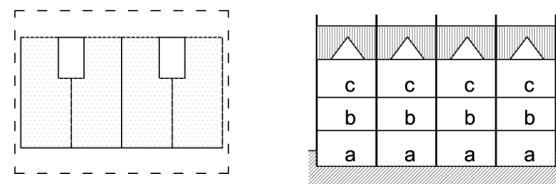

### Comparison of efficiency between units with different volumetric arrangements\*

	Land	Infra.	Construction
<b>V1</b>	1.00	1.00	1.00
<b>V2</b>	1.50**	1.50**	0.95**
<b>V3</b>	2.00**	2.00**	1.80***
<b>V4</b>	3.00**	3.00**	2.60****
<b>V5</b>	3.00**	3.00**	2.70****

\* : Different housing types with same floor area.

\*\* : Estimation.

\*\*\* :Considering extra expense on the finished attic.

\*\*\*\* :Considering extra expense on the additional kitchens, baths, entry/exit, and separate heating and electric.

### Example :

Unit (V1) description : 2-story, 1 full bath, 1 kitchen, finished basement.

Unit (V1) width : 6m unit depth : 12m

Lot depth : 30m

Land cost : \$269.10 / sq.m.

	Land Cost (\$)	Eff.*	Cons.Cost* (\$)	Eff.*
<b>V1</b>	48,438	1.00	113,374	1.00
<b>V2</b>	36,329	1.50	117,031	0.97
<b>V3</b>	24,219	2.00	62,827	1.80
<b>V4</b>	16,146	3.00	42,951	2.64
<b>V5</b>	16,146	3.00	42,446	2.67

Eff. : Efficiency, compared with V1.

Cons. Cost : Construction cost for inner unit.

## Width

### W1 Row 4.2 meter (single family)

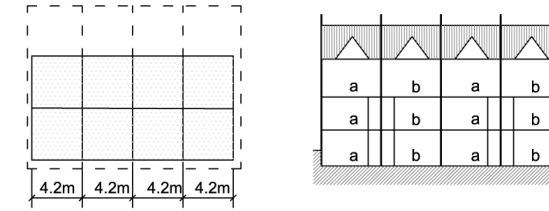

### W2 Row 4.8 meter (single family)

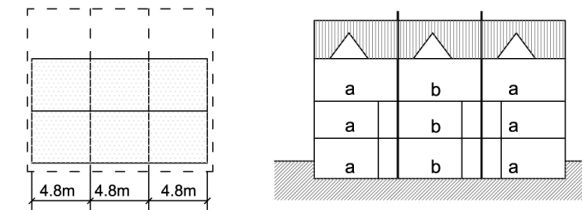

### W3 Row 5.4 meter (single family)

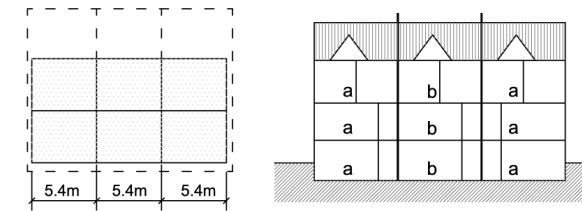

### W4 Row 6.0 meter (single family)

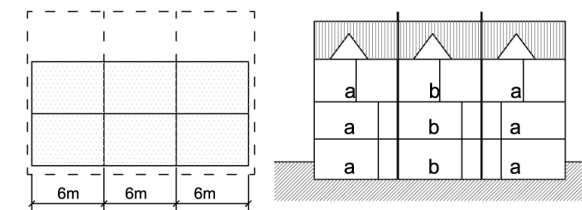

Unit description : 2-story, 1 full bath, 1 half bath, 1 kitchen, finished basement.

Unit width : 4.2m/ 4.8m/ 5.4m/ 6m unit depth : 12m

Lot depth : 30m

Land cost : \$269.10 / sq.m.

	Land Cost (\$)	S.*(%)	Cons. Cost* (\$)	S.*(%)
<b>W1</b>	33,907	30.00	93,616	15.98
<b>W2</b>	38,750	20.00	96,779	13.14
<b>W3</b>	43,594	10.00	103,804	6.83
<b>W4</b>	48,438	0.00	111,416	0.00

Cons. Cost\* : Construction Cost for inner unit.

S\* : Saving, compared with W4.

Saving on the land cost shows inverse ratio that of unit's width.

Base cost per square foot of living area is higher for a smaller unit with narrow width, compared with a bigger unit with wider width.

## Grouping

**G1** Four units in a row

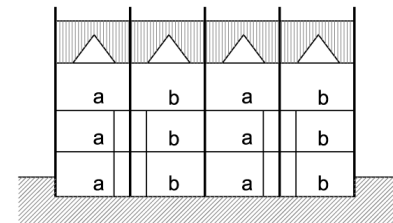

**G2** Six units in a row

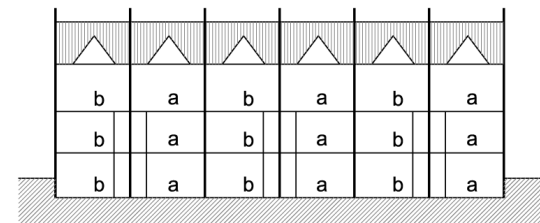

**G3** Eight units in a row

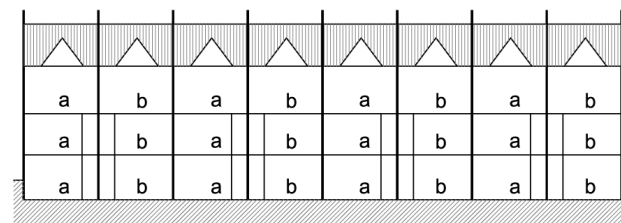

### Comparison between units in a row and single family detached house\*

	Saving (%)		
	Land	Infra.	Building***
<b>G1</b>	50.0**	50.0**	7.50
<b>G2</b>	50.0**	50.0**	8.33
<b>G3</b>	50.0**	50.0**	8.75

### Comparison of efficiency between townhouses with different number of units

	Land	Infra.	Building***
<b>G1</b>	1.00	1.00	1.000
<b>G2</b>	1.07	1.07	1.009
<b>G3</b>	1.11	1.11	1.014

\* : Different housing types with same unit size.

\*\* : Estimation.

\*\*\* : The construction cost of an inner unit of a townhouse is 90% that of a single family detached house.  
The construction cost of an end unit of a townhouse is 95% that of a single family detached house.

### Example :

Unit description : 2-story, 1 full bath, 1 half bath, 1 kitchen, finished basement.

Assumed side setback is one-half that of the unit's width.

Unit width : 6m unit depth : 12m

Lot width : 12m (single family detached house)

6m (townhouse)

Lot depth : 30m

Land cost : \$269.10 / sq.m.

	Land Cost (\$)			Construction Cost (\$)		
	Total	Unit	Eff.*	Total	Unit	Eff.*
<b>Ga*</b>	96,876	96,876	0.63	150,459	150,459	0.925
<b>Gb*</b>	145,314	72,657	0.83	285,871	142,936	0.974
<b>G1</b>	242,190	60,548	1.00	556,698	139,175	1.000
<b>G2</b>	339,066	56,511	1.07	827,524	137,921	1.009
<b>G3</b>	435,942	54,493	1.11	1,098,351	137,294	1.014

Eff\* : Efficiency, compared with G1.

Ga\* : Single family detached house.

Gb\* : Semi-detached house.

## Units-Grouping

**G4-1** Combination of types

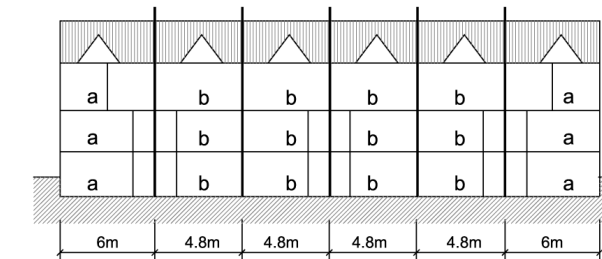

**G4-2** Combination of types

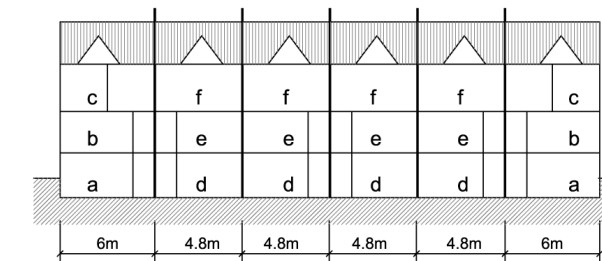

**G5-1** Combination of Widths

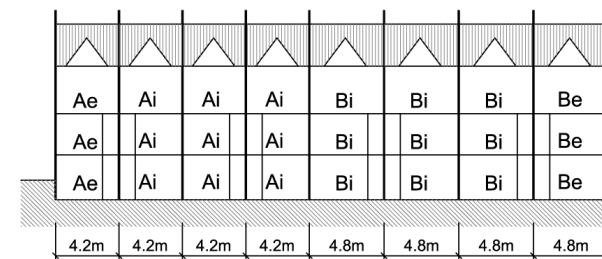

**G5-2** Combination of Widths

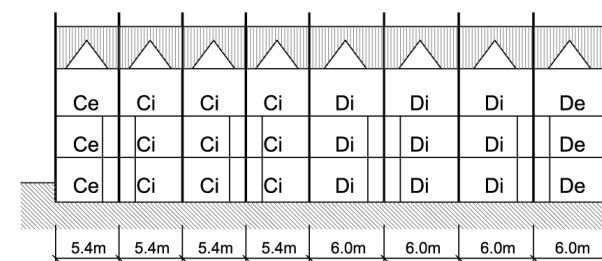

G4-1 description : 2-story, 1 full bath, 1 half bath, 1 kitchen, finished basement.

G4-2 description : 2-story, 1 full bath for each unit, 1 kitchen for each unit, finished basement used as one unit.

Assumed side setback is one-half that of the unit's width.

Unit width : 6m / 4.8m unit depth : 12m

Lot depth : 30m

Land cost : \$269.10 / sq.m.

	Land Cost (\$)			Construction Cost (\$)			
	End U.	Inner U.	S.*(%)	End U.	S.*(%)	Inner U.	S.*(%)
<b>G4-1</b>	72,657	38,750	0.00	142,936	0.00	116,922	0.00
<b>G4-2</b>	24,219	12,917	66.67	54,267	62.03	45,248	61.30

S\* : Saving.

G4-1 : Townhouse.

G4-2 : Plex.

Unit description : 2-story, 1 full bath, 1 half bath, 1 kitchen, finished basement.

Assumed side setback is one-half that of the unit's width.

Unit width : 4.2m/ 4.8m/ 5.4m/ 6m unit depth : 12m

Lot depth : 30m

Land cost : \$269.10 / sq.m.

	Land Cost (\$)	S.*(%)	Cons. Cost*(\$)	S.*(%)
<b>G5-1</b>	326,957		909,653	
<b>Ai</b>	33,907	53.33	110,745	21.28
<b>Ae</b>	50,860	30.00	116,897	16.90
<b>Bi</b>	38,750	46.67	113,553	19.28
<b>Be</b>	58,126	20.00	119,862	14.80
<b>G5-2</b>	414,145		1,041,768	
<b>Ci</b>	43,594	40.00	123,604	12.14
<b>Ce</b>	65,391	10.00	130,471	7.25
<b>Di</b>	48,438	33.33	133,271	5.26
<b>De</b>	72,657	0.00	140,675	0.00

Cons. Cost\* : Construction Cost.

S\* : Saving, compared with De.

Saving on the land cost shows inverse ratio that of unit's width.

## Parking

### P1 Indoor access from the front

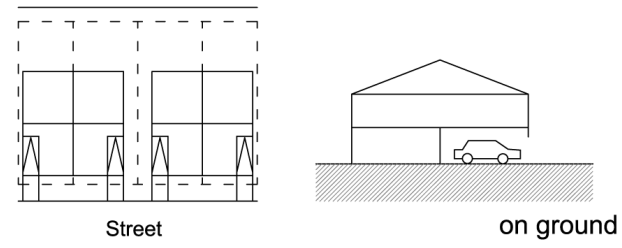

### P2 Indoor side access

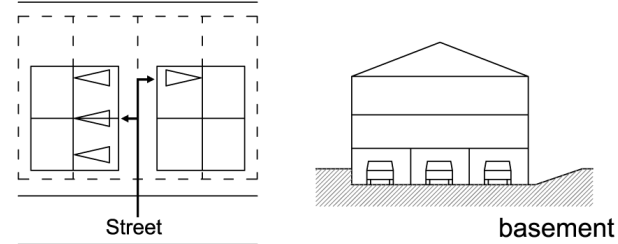

### P3 Indoor back access

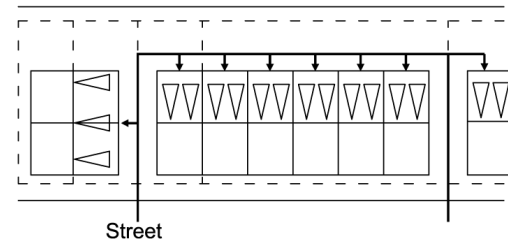

### P4 Outdoor access from the front

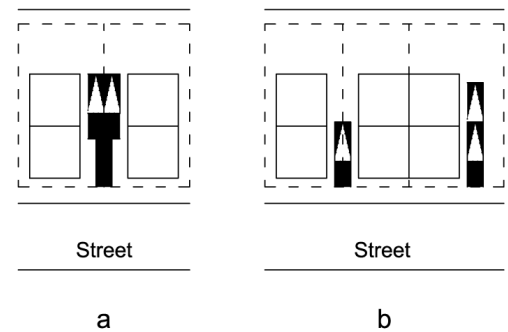

### Built-In Garage (P1)

Constructed under the second floor living space (and above basement level of dwelling). Reduces gross square feet of living area.

### Basement Garage (P2, P3)

Constructed under the roof of the dwelling but below the living area.

### Detached Garage (P5a, P6b)

Constructed apart from the main dwelling. Shares no common area or wall with the dwelling.

	Cost for each parking place (\$)				
	Land	Excavation	Driveway	Building	Total
<b>P1</b>	7,265		655	15,490	23,410
<b>P2</b>	6,458	428	654	7,697	15,237
<b>P3</b>	10,162	227	1,183	5,773	17,345
<b>P4a</b>	9,688		1,340		11,028
<b>P4b</b>	9,688		1,340		11,028
<b>P5a</b>	14,531		2,011		16,542
<b>P5b</b>	14,531		1,341	7,928	23,800
<b>P6a</b>	9,688		1,340		11,028
<b>P6b</b>	9,688		670	7,511	17,869

## Parking

### P5 Outdoor front access with servitude between units

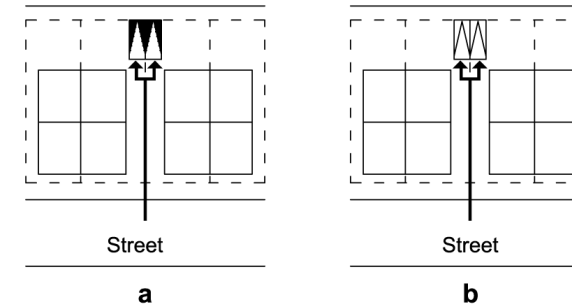

### P6 Outdoor back access

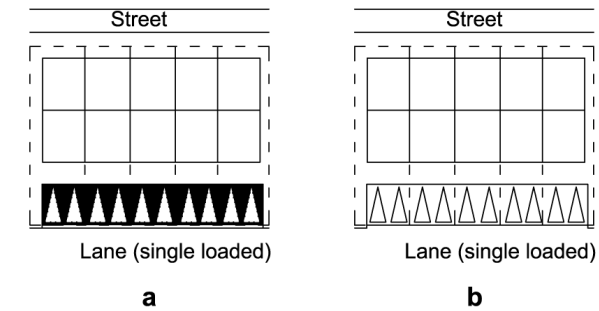

## Ground Relation

### GR1 Units with slab on grade

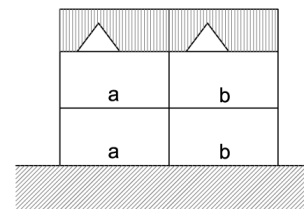

### GR2 Units with basement

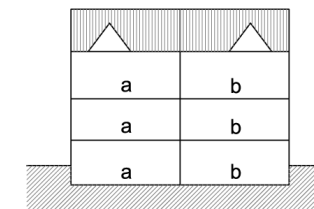

Unit description : 2-story, 1 full bath, 1 half bath, 1 kitchen, with/ without finished/ unfinished basement.

Unit width : 6m unit depth : 12m

		Cons. Cost*(\$)	Eff.*
<b>GR1</b>	No Basement	144,366	1.21
<b>GR2</b>	Unfinished Basement	168,713	1.08
	Finished Basement	182,429	1.00

Cons. Cost\* : Construction Cost.

Eff\* : Efficiency, the bigger the better.

## Roofs

### R1 Flat Roof



### R2 Pitched Roof



### R3 Pitched Roof with an Attic

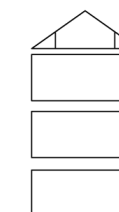

### Comparison of cost per sq. m.(\$)

	Material		Installation		Total		Total
	Frame	Roof	Frame	Roof	Frame	Roof	
<b>R1</b>	16.47	24.65	14.42	20.88	30.89	45.43	76.32
<b>R2</b>	36.38	9.26	24.76	16.25	61.14	25.51	86.65
<b>R3</b>	38.64	19.70	32.19	55.97	70.83	75.67	146.50*

\* : Cost for unfinished attic. Cost for finished attic is \$256.40/sq.m.

### Interior Completion

**I1** All Floors Finished

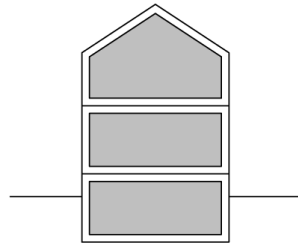

**I2** Unfinished Basement

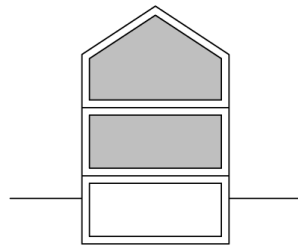

**I3** Second Floor Unfinished

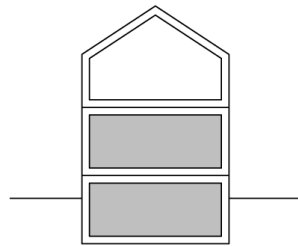

**I4** Unfinished Attic

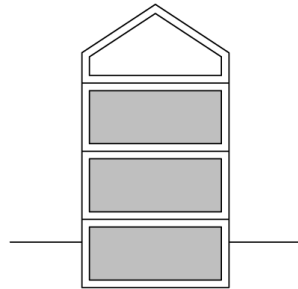

**I5** Second Floor and Basement Unfinished

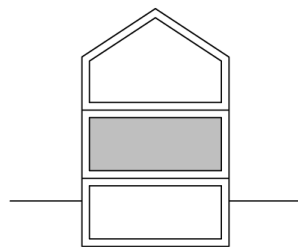

	Cost per unit (\$)				Saving (%)
	4.2m**	4.8m**	5.4m**	6.0m**	
<b>I1</b>	125,744	143,707	161,670	170,659	0.00
<b>I2</b>	116,450	133,086	149,722	157,828	7.45***
<b>I3</b>	118,428	136,247	153,090	161,590	5.57***
<b>I4</b>	129,436	147,926	166,416	175,933	-3.02***
<b>I5</b>	109,134	125,626	141,142	148,759	13.02***

\* : Unit's depth is 12m, inner unit.

\*\* : Width of the unit.

\*\*\* : Average saving, compared with I1.

### Wet Service/Utilities

**U1** Three Bathrooms

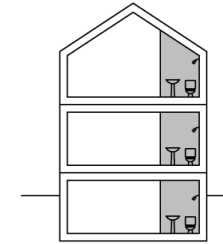

**U2** Fittings for Bathroom in the Basement

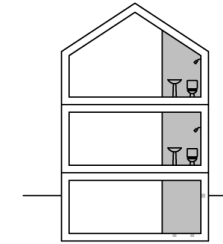

**U3** One Bathroom + Powder Room

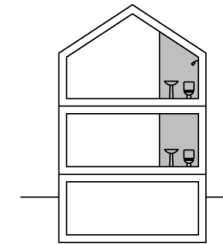

**U4** One Bathroom

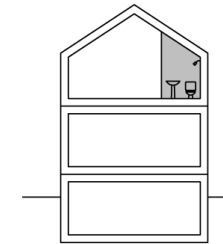

**U5** Separated Plumbing

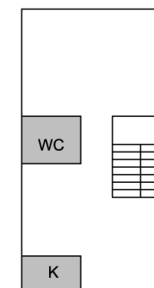

**U6** Back to Back Plumbing

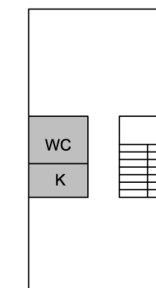

	Cost (\$)	Saving (%)
<b>U1</b>	11,695	0.00
<b>U2</b>	10,740	8.17
<b>U3</b>	6,718	42.56
<b>U4</b>	4,620	60.50

	Cost per linear meter (\$)
<b>Cast Iron Pipe</b> (4" d)	49.62
<b>Copper Pipe</b> (3/4" d)	15.32
<b>Plastic Pipe</b> (1" d)	19.72
<b>Steel Pipe</b> (1" d)	19.19

Example		
	Cost (\$)	Saving (%)
<b>U5</b>	8,006	0.00
<b>U6</b>	7,364	8.02

### Facade Design - Material

**Mt1** Siding

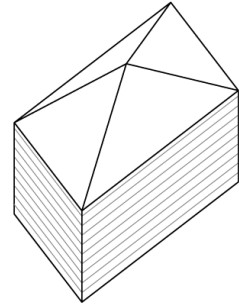

**Mt2** Stucco

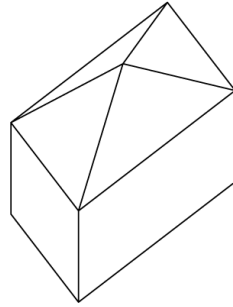

**Mt3** Brick

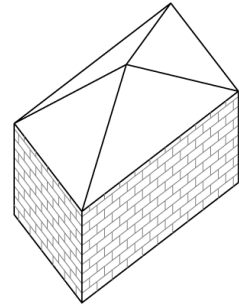

	Cost per sq. m. (\$)		
	Material	Labor	Total
<b>Mt1</b>	17.01	19.05	36.17
<b>Mt2</b>	3.98	28.74	44.67
<b>Mt3</b>	33.80	68.25	102.05

### Facade Design - Balconies

**B1** No Balcony

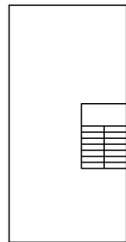

**B2** Back Only

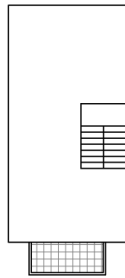

**B3** Front Only

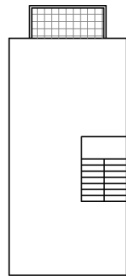

**B4** Front and Back

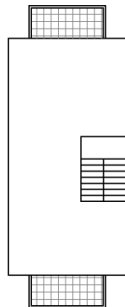

	Cost per sq. m. (\$)		
	2.32 sq. m.	4.65 sq. m.	9.29 sq. m.
<b>B1</b>	0.00	0.00	0.00
<b>B2</b>	339.15	227.29	177.31
<b>B3</b>	339.15	227.29	177.31
<b>B4</b>	678.30	454.58	354.62

### Interior Layout

**L1** 4.2 m x 12.0 m

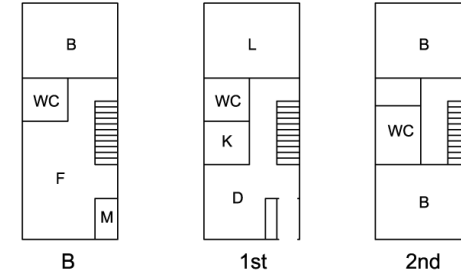

**L2** 4.8 m x 12.0 m

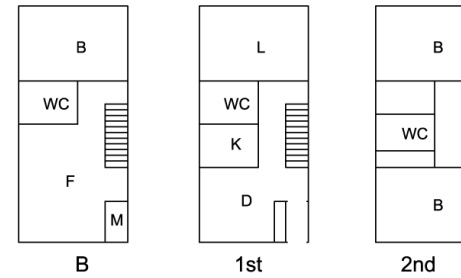

**L3** 5.4 m x 12.0 m

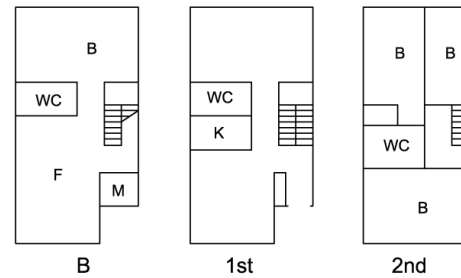

**L4** 6.0 m x 12.0 m

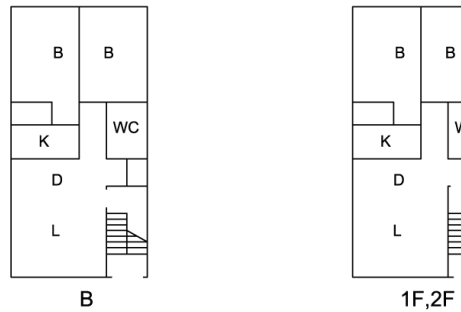

		Interior cost for each floor (\$)				
		Wall	Doors	Bath	Kitchen	Total
<b>L1</b>	B	735.00	1370.52	3898.40		6003.92
	1st	1209.60	1370.52	3898.40	4107.40	10338.08
	2nd	1008.00	2409.40	3898.40		7315.80
<b>L2</b>	B	840.00	1370.52	3898.40		6108.92
	1st	1382.40	1370.52	3898.40	4107.40	10758.72
	2nd	1152.00	2409.40	3898.40		7459.80
<b>L3</b>	B	945.00	1370.52	3898.40		6213.92
	1st	1555.20	1370.52	3898.40	4107.40	10931.52
	2nd	1296.00	3385.68	3898.40		8580.08
<b>L4</b>	B	2304.00	3683.45	3898.40	4107.40	13993.25
	1st	2304.00	3683.45	3898.40	4107.40	13993.25
	2nd	2304.00	3683.45	3898.40	4107.40	13993.25

### Kitchen

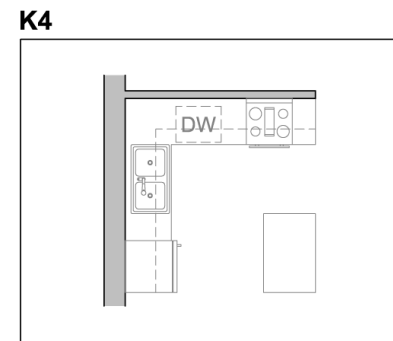
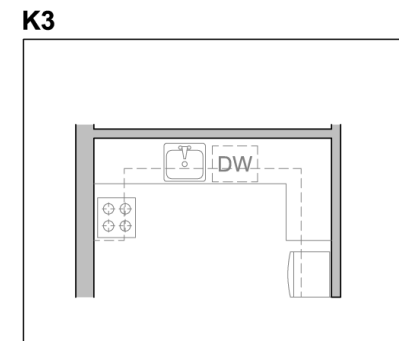
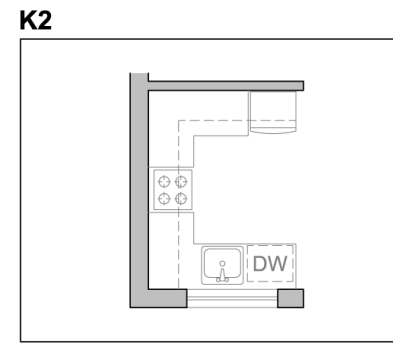
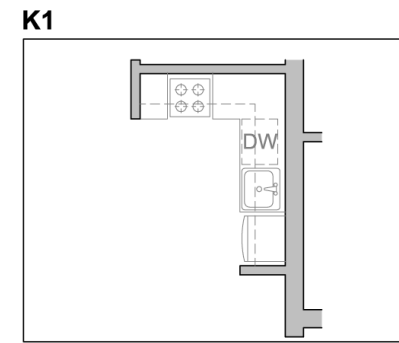

Type	Cost (\$)
<b>K1</b>	2,866
<b>K2</b>	3,525
<b>K3</b>	3,676
<b>K4</b>	3,759

Appliances include refrigerator, range (76.2cm free standing, 1 oven), sink, and dishwasher (all appliances include plumbing and electrical rough-in and hook-ups);  
kitchen system include bottom cabinets, counter top, top cabinets, and soffit framing;  
all in economy grade.

### Laundry

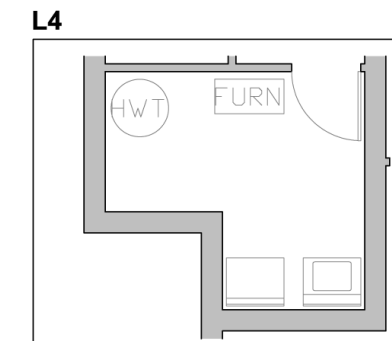
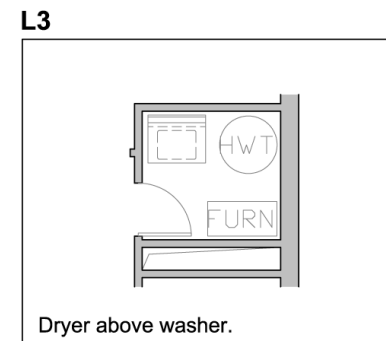
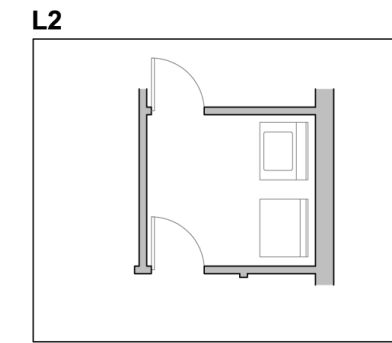
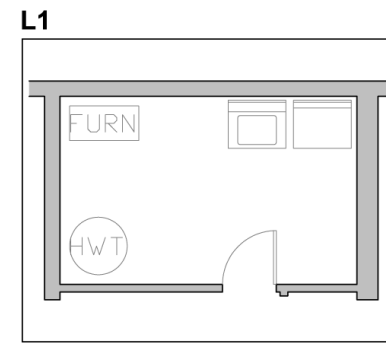

Type	Cost (\$)
<b>L1</b>	3,971
<b>L2</b>	4,007
<b>L3</b>	2,640
<b>L4</b>	3,755

Mechanical facilities not included.  
Floor area is shared by laundry and mechanical when they are arranged in one room.

### Bathroom

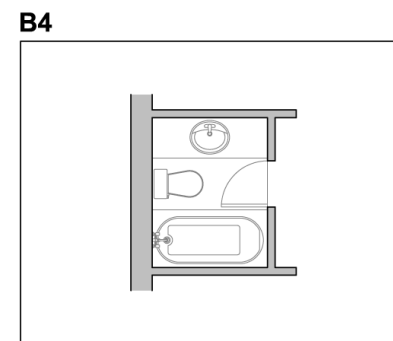
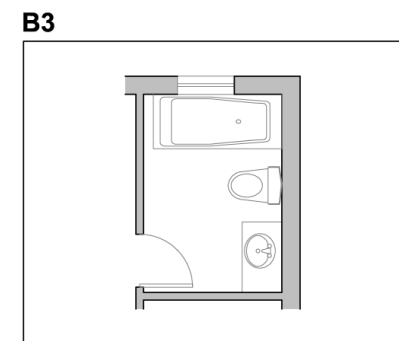
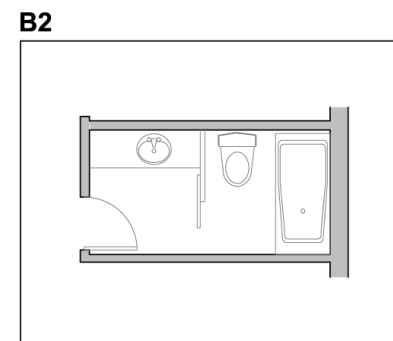
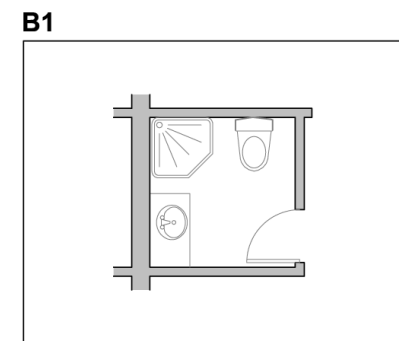

Type	Cost (\$)
<b>B1</b>	2,603
<b>B2</b>	3,038
<b>B3</b>	2,965
<b>B4</b>	2,824

### Storage

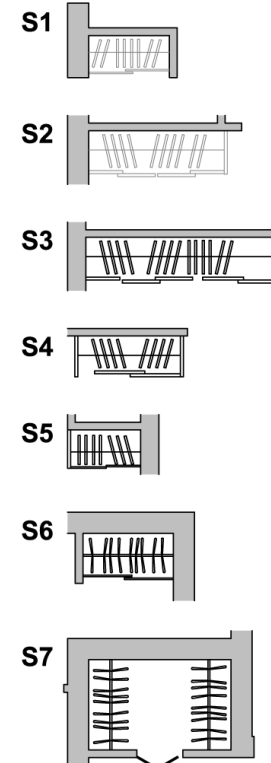

Type	Cost (\$)
<b>S1</b>	304
<b>S2</b>	439
<b>S3</b>	620
<b>S4</b>	300
<b>S5</b>	230
<b>S6</b>	250
<b>S7</b>	414

Flooring				
		Cost per sq. m. (\$)		
		Material	Labor	Total
<b>F1</b>	Carpet	6.57~68.68	6.24~7.53	12.81~75.67
<b>F2</b>	Linoleum	14.53~15.72	7.00	21.53~22.71
<b>F3</b>	Tiles	44.03	17.33	61.36
<b>F4</b>	Parquet	28.53~75.78	26.16~37.46	54.68~113.24

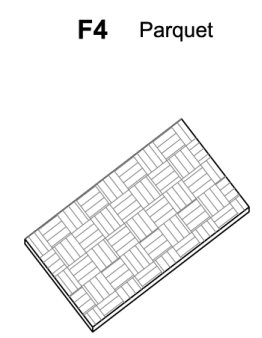
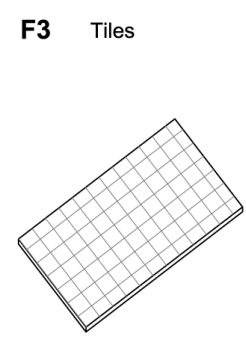
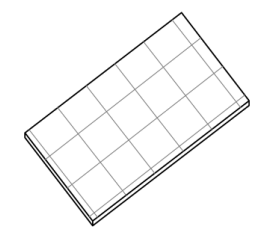
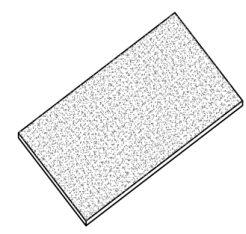

Landscaping				
		Cost per sq. m. (\$)		
		Material	Installation	Total
<b>Y1</b>	No Grass	0.00	0.00	0.00
<b>Y2</b>	Grass	6.35	0.54	6.89
<b>Y3</b>	Deck	69.11	37.03	106.24

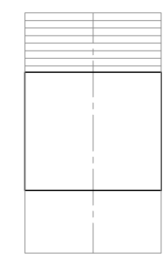
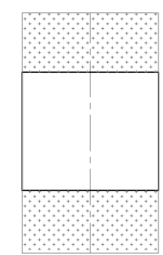
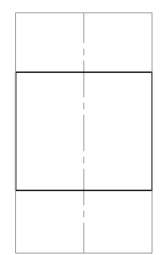

Heating System				
		Cost per system* (\$)		
		Material	Installation	Total
<b>H1</b>	Electric	843.70	969.10	1812.80
<b>H2</b>	Gas	2036.12	1773.24	3809.37
<b>H3</b>	Oil	2316.73	1955.98	4272.71

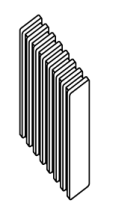
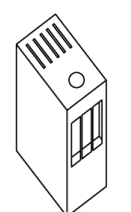
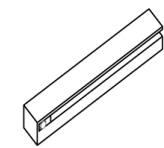

\* : Heating only, 1200 sq. ft. building.

Cabinets				
		Cost per linear meter (\$)		
		Material	Labor	Total
<b>C1</b>	Melamine	142.92	29.27	172.18
<b>C2</b>	Oak	524.03	44.39	568.42

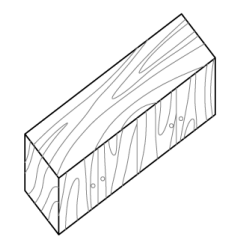
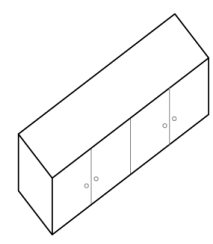

Construction Techniques		
	Form	Enhance affordability
<b>CT1</b>	Conventional	1. Speed up construction by a. reduce on-site labor, b. allow for year-round construction, c. higher safety and comfort level for workers.  1. Lower material costs by a. quantity purchasing of materials, b. mass production assembly techniques, c. use of less skilled labor.
<b>CT2</b>	Prefabricated components	
	Modular housing	
	Manufactured housing	

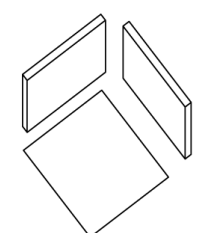
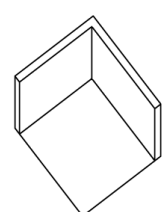

Manufactured housing reduces by about one third the required income to carry a home compared to a conventionally built home of the same size (source: CMHC).

Bathroom Walls				
		Cost per sq. m. (\$)		
		Material	Labor	Total
<b>W1</b>	Paint	12.92	28.31	41.23
<b>W2</b>	Tiles	24.00	16.47	40.47

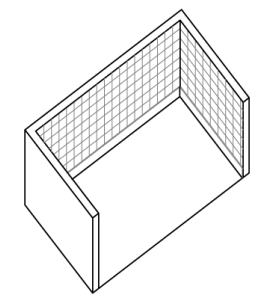
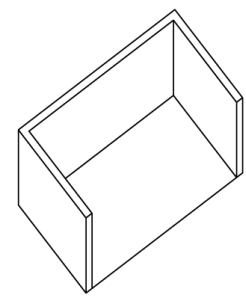

Marketing Strategies	
<b>MS1</b>	Offer Package
<b>MS2</b>	Menu

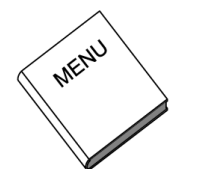
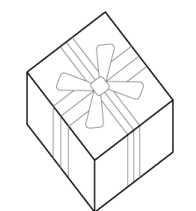

## Planning Options

The geographic area on which we concentrated our planning efforts was the market sector at the west end of the site. We regarded the option suggested by Sala et Barbarese, Architects in their original proposal as a departure point. According to our estimation the cost of the two-storey single-family townhouses in the proposed scheme would be \$149,952. The cost of the three-storey single-family townhouses would be \$214,283, affordable to a buyer with an income of over \$60,000, which is the upper end of the buyers' affordability scale. In the original plan there was also a design for large walk-up units at a cost of \$134,466 and smaller units at a cost of \$87,967. We therefore wanted to offer alternative schemes that will include units with lower costs than the original options. We based our target cost on the level of income in the study area and we wanted to offer as wide as possible range of affordable units. We also bore in mind the demographic make-up of the population in the district which one assumes will constitute the bulk of the homebuyers.'

We therefore prepared five additional planning options. In each option we gradually increased the density and, as a result, the number of units, which contributed to lowering the dwellings' costs. Densification, however, is a double-edged sword. When more units are built, the advantage is lower cost since more units share the cost of land and infrastructure. Yet, at the same time, more cars have to be accommodated on the site, which may lower the overall curb appeal of the project. There is, therefore, a need to find a balance between number of units built, parking, and open spaces.

The instructions that we were given at the outset of the study were that no changes would be possible in the overall master plan, to which we had to remain close. We therefore had to work within the confines of the units themselves.

The total number of units in Option 1 (original scheme) was 89. In Option 2 we increased the total number of units to 105. We also introduced two new types: a row of triplexes at the southern edge of the site, and a walk-up apartment building with three apartments per floor. We suggested that the parking in the single-family units could have entrances from the front, but it could easily have an entrance from the back with an alley. The overall cost of the project as a result was found to be \$11,215,248. The density is 116 units per hectare. One needs to note that the majority of the units are under \$90,000, which puts them within a comfortable affordability range.

The number of units in Option 3 rose to 111. Also, the composition of the units changed. We introduced a new type: 5.4-meter-wide duplex. The unit, common in NDG, permits large and small households to share the same structure and therefore we assumed, has a high marketing potential.

The cost of an upper unit of the duplex is estimated to be \$68,703 and the lower \$116,012. The number of triplexes was also increased. The higher density creates a parking challenge. The parking can be, once again, at the back or at the front. Back entrance parking will likely affect the size of the rear yard and this is a worthwhile consideration.

Another new type was introduced in Option 4. Zipper lots contributed to the increase of the overall number of units, bringing the total to 119. The advantage with this design is the more efficient use of land. It is, in fact, a variation of semi-detached since each unit has its own direct entrance from the front. Yet, the land is used more efficiently since the units are "zipped" into each other. The trade-off is in the reduced outdoor space and the fact that the front units have front parking, which provides a bad image to the street. One needs to note that the majority of the units are within a comfortable affordability range.

In Option 5, the entire western row is made of duplexes and triplexes. The overall number of units rose to 125. There are only 30 units with a cost above \$100,000, which makes the option highly affordable. The challenge is parking. We suggested that in order to maintain this high density level, all parking at the western side will be outdoors at the rear. This will be done at the expense of the backyard size. We kept the walk-up units at the same ratio with underground parking.

The share of the triplexes and, as a result, the overall number of units, rose in Option 6. We offered 45 units of 6-meter-wide triplexes with an average floor area of 75 square meters. Although these are single-floor units, we believe that similar to the Next Home design, which was originated at McGill, the structure can be arranged whereby the buyers will be offered a choice of the number of floors that they wish to acquire. The row can be designed to be a mix of duplexes and triplexes. The units in this alternative are, once again, comfortably affordable and will enable single-person households to become homeowners.



**Overview of Planning Options**

**Planning Option-1(Original) : 4.8m Wide SF Units and Walkup(two units per floor)**

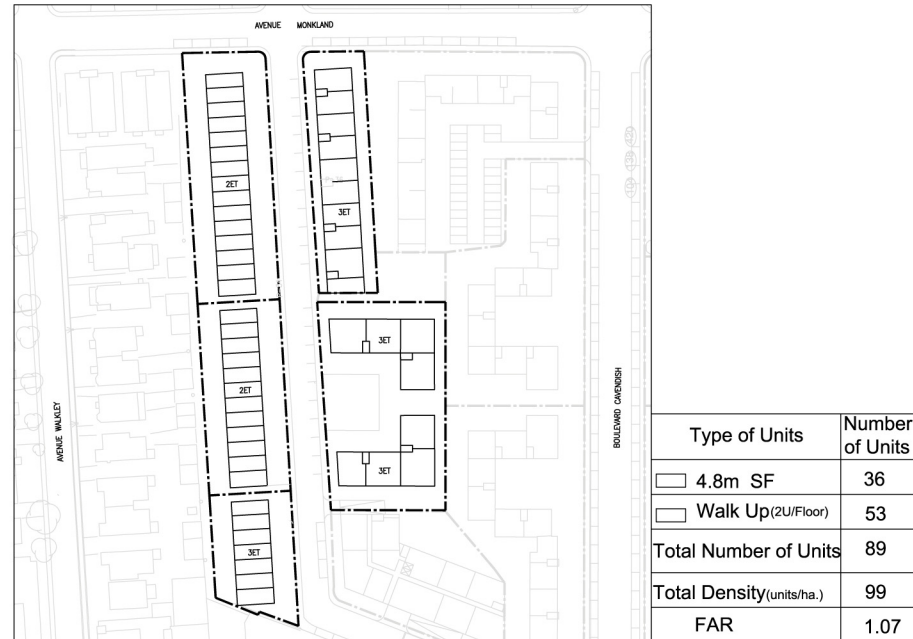

**Planning Options-2 : 5.4m Wide Triplex and 4.8m Wide SF**

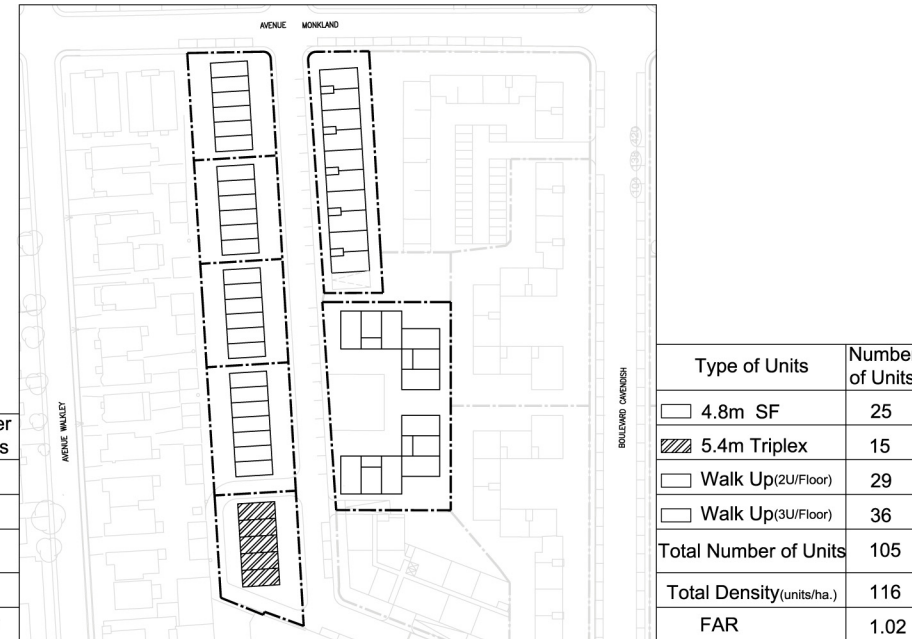

**Planning Options-3 : 6m Wide Triplex, 5.4m Wide Duplex and 4.2m Wide SF**

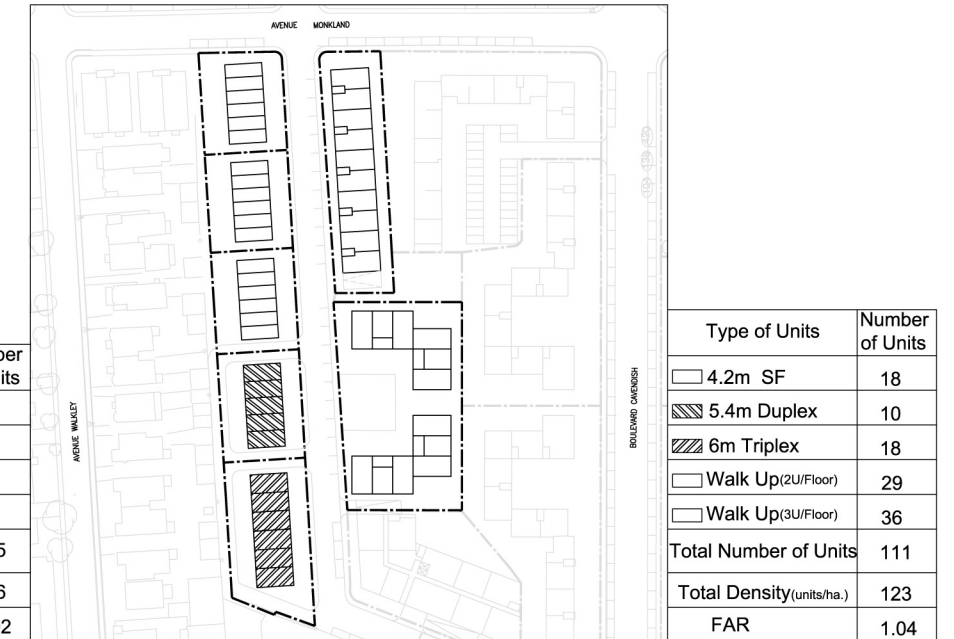

**Planning Options-4 : Zipper Lot and 5.4m Width Triplex**

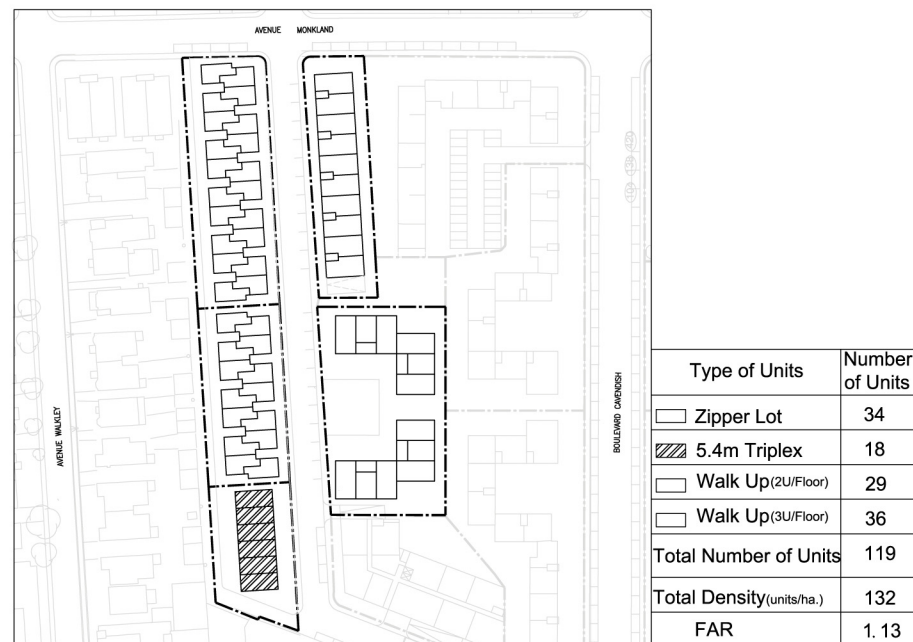

**Planning Option-5 : 6m Wide Triplex and 5.4m Wide Duplex**

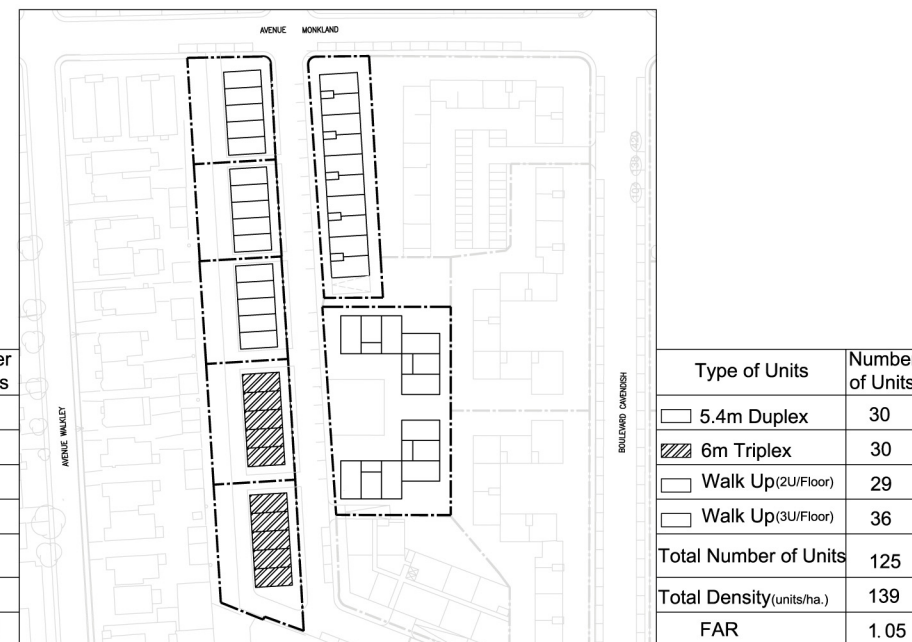

**Planning Option-6 : More 6m Wide Triplex and Fewer 5.4m Wide Duplex**

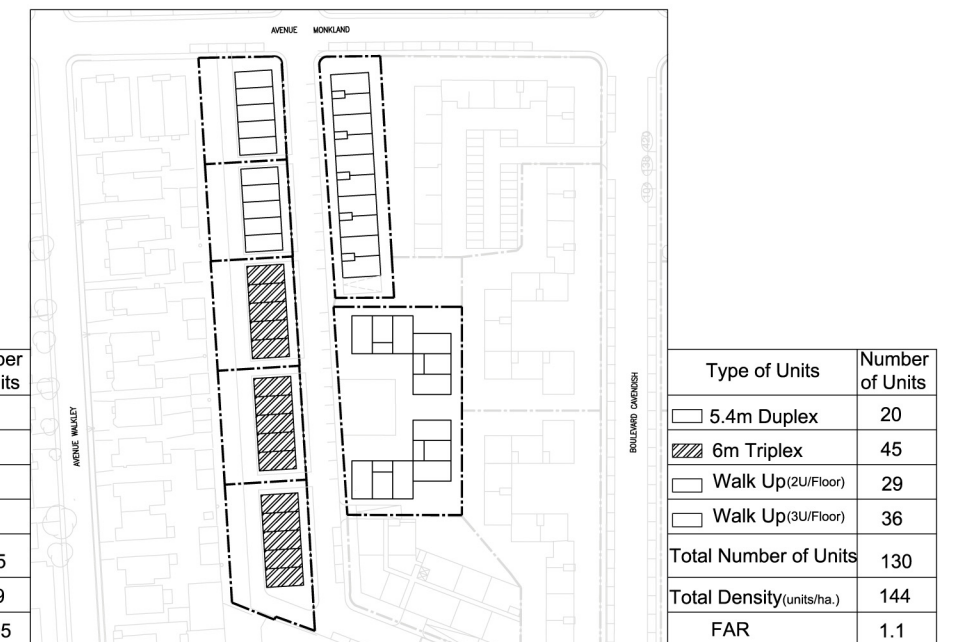

**Planning Option-1(Original) : 4.8m Wide SF Units and Walkup(two units per floor)**

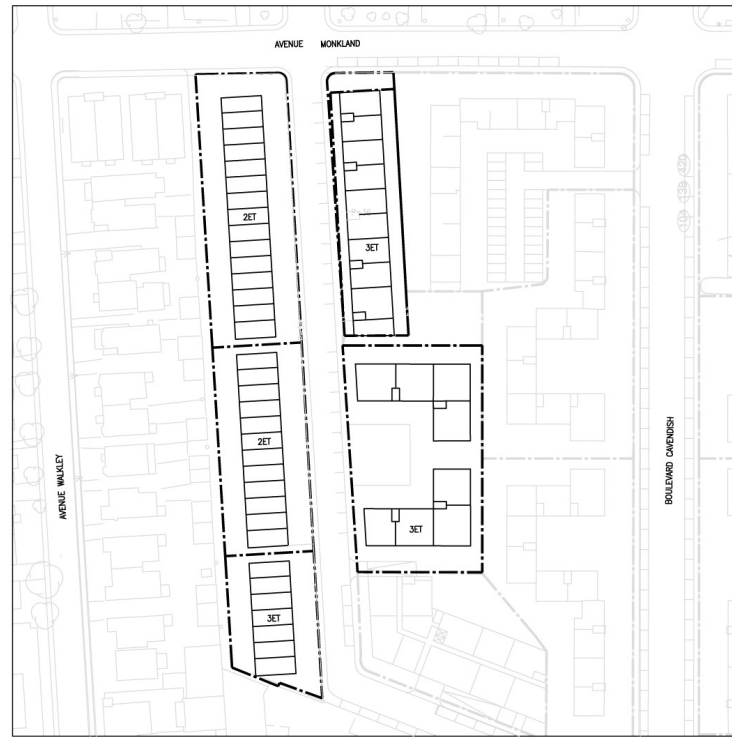

1. Units

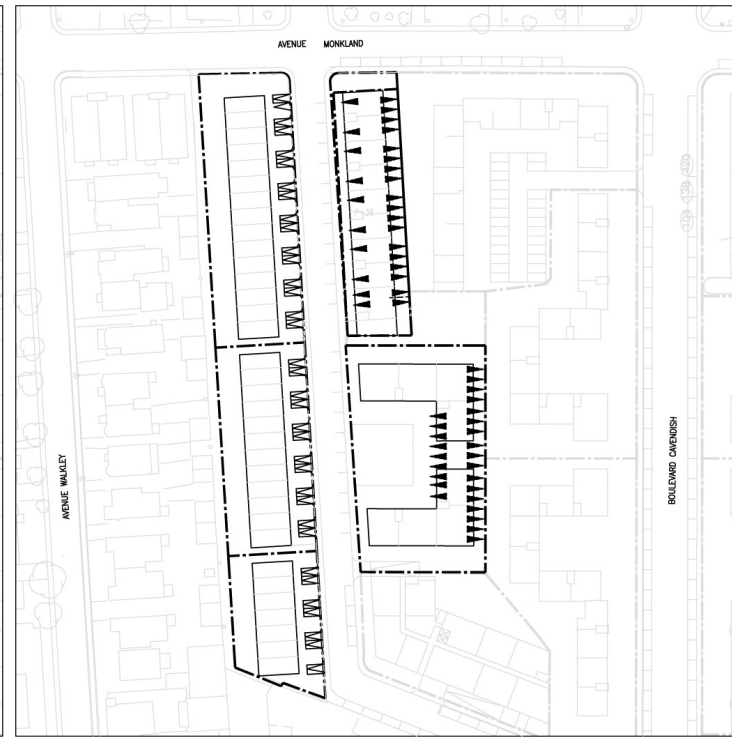

2. Parking and Circulation

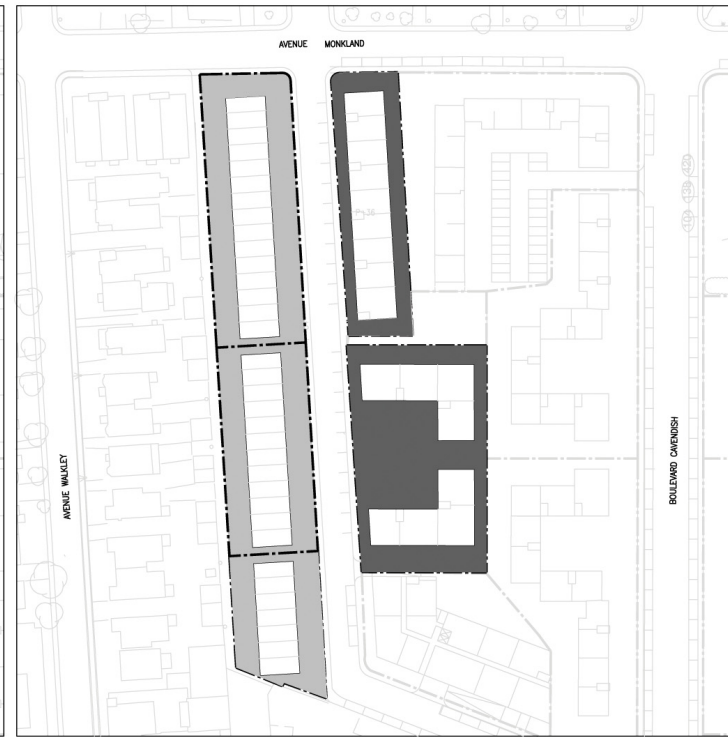

3. Openspace and Landscape

Building	Item	Unit (\$/s.m.)	Quantity (s.m.)	Cost (\$)
4.8mSF 2-story	Land	269	3,817	1,026,773
	Construction	816	3,110	2,536,602
	Landscape	30	2,262	68,843
	<b>Total*</b>			<b>4,177,051</b>
4.8mSF 3-story	Land	269	1,020	274,380
	Construction	888	1,210	1,074,800
	Landscape	29	617	18,055
	<b>Total*</b>			<b>1,572,320</b>
7.32m W 2u	Land	269	1,527	410,763
	Construction	714	2,565	1,832,593
	Landscape	8	649	5,443
	<b>Total*</b>			<b>2,586,119</b>
11.32m W 2u	Land	269	2,658	715,002
	Construction	717	2,988	2,143,104
	Landscape	11	1,662	18,586
	<b>Total*</b>			<b>3,308,196</b>
<b>Total</b>				<b>11,643,686</b>

4. Overall alternative cost

\* : Including Overhead & Profit (15%).

Legend	Type of Units	Number of Units	Density of Each Block	FAR of Each Block
[Symbol]	4.8m SF	36	74	0.86
[Symbol]	Walk Up(2U/Floor)	53	127	1.33
Total Number of Units		89		
Total Density(units/ha.)		99		
FAR		1.07		

Legend	Type of Units	Parking	
		Indoor [Symbol]	Outdoor [Symbol]
[Symbol]	4.8m SF	36	
[Symbol]	Walk Up(2U/Floor)	53	
Total Number of Parking		89	

Legend	Type of Units	Openspace(m <sup>2</sup> )	
		Private [Symbol]	Public [Symbol]
[Symbol]	4.8m SF	2880	
[Symbol]	Walk Up(2U/Floor)	2390	
Total Area (m <sup>2</sup> )		5270	

Cost per dwelling unit\* (\$)

Dwelling	Land	Construction	Landscape	Total**
4.8mSF 2-story	34,217	93,202	2,452	149,352
4.8mSF 3-story	34,217	149,664	2,452	214,283
7.32m W 2u	14,164	62,141	188	87,967
11.32m W 2u	29,792	86,352	774	134,456

\* : Inner unit.

\*\* : Including Overhead & Profit (15%).

**Planning Option-2 : 5.4m Wide Triplex and 4.8m Wide SF Units**

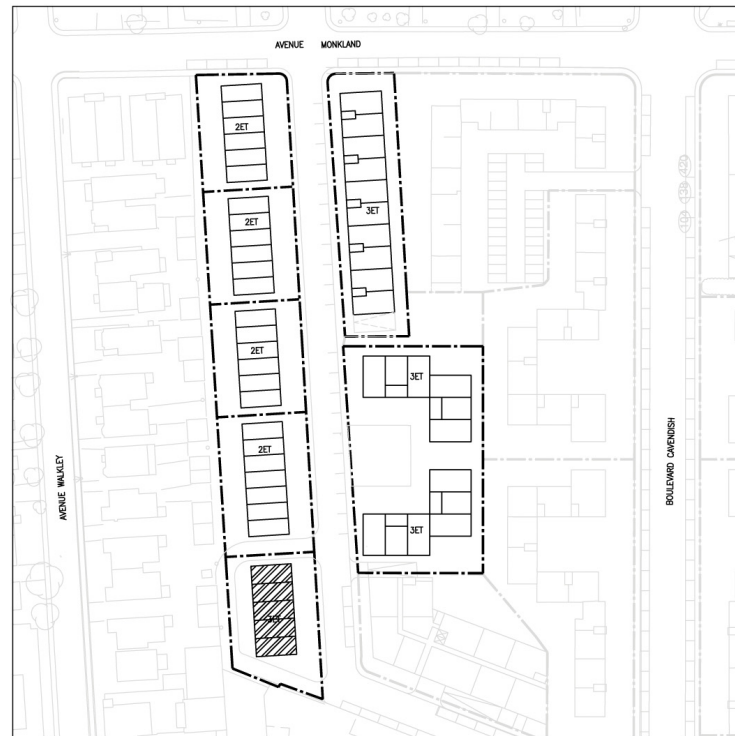

1. Units

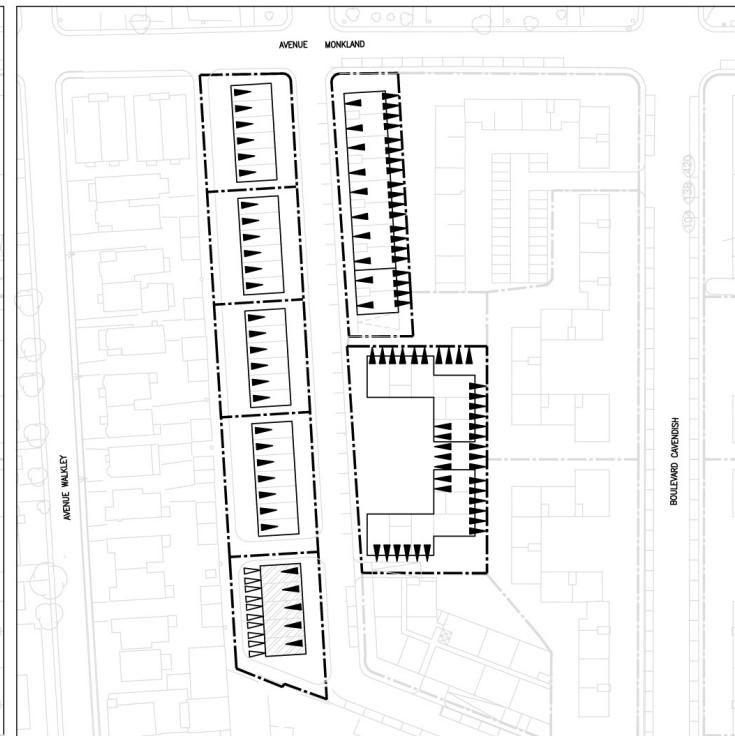

2. Parking and Circulation



3. Openspace and Landscape

Building	Item	Unit (\$/s.m.)	Quantity (s.m.)	Cost (\$)
4.8mSF 2-story	Land	269	3,817	1,026,773
	Construction	823	2,880	2,370,346
	Landscape	28	2,377	65,692
	<b>Total*</b>			<b>3,982,233</b>
5.4m Triplex	Land	269	1,020	274,380
	Construction	929	972	903,285
	Landscape	35	696	24,469
	<b>Total*</b>			<b>1,382,454</b>
W 2u	Land	269	1,527	410,763
	Construction	742	2,435	1,806,090
	Landscape	7	715	4,980
	<b>Total*</b>			<b>2,555,108</b>
W 3u	Land	269	2,658	715,002
	Construction	729	2,922	2,131,740
	Landscape	11	1,684	18,869
	<b>Total*</b>			<b>3,295,453</b>
<b>Total</b>				<b>11,215,248</b>

4. Overall alternative cost

\* : Including Overhead & Profit (15%).

Legend	Type of Units	Number of Units	Density of Each Block	FAR of Each Block
	4.8m SF	25	83	0.8
	5.4m Triplex	15		
	Walk Up(2U/Floor)	29	155	1.28
	Walk Up(3U/Floor)	36		
Total Number of Units		105		
Total Density(units/ha.)		116		
FAR		1.02		

Legend	Type of Units	Parking	
		Indoor ■	Outdoor □
	4.8m SF	25	
	5.4m Triplex	9	6
	Walk Up(2U/Floor)	29	
	Walk Up(3U/Floor)	36	
Total Number of Parking		105	

Legend	Type of Units	Openspace(m <sup>2</sup> )	
		Private ■	Public ■
	4.8m SF	2240	
	5.4m Triplex		445
	Walk Up(2U/Floor)		715
	Walk Up(3U/Floor)		1680
Total Area (m <sup>2</sup> )		5080	

Cost per dwelling unit\* (\$)

Dwelling	Land	Construction	Landscape	Total**
4.8mSF 2-story	34,217	93,202	2,452	149,352
5.4m Triplex	18,292	58,183	1,631	89,822
W 2u	13,692	59,393	166	84,239
W 3u	19,861	57,263	524	89,295

\* : Inner unit.

\*\* : Including Overhead & Profit (15%).

**Planning Options-3 : 6m Wide triplex,5.4m Wide Duplex and 4.2m Wide SF Units**

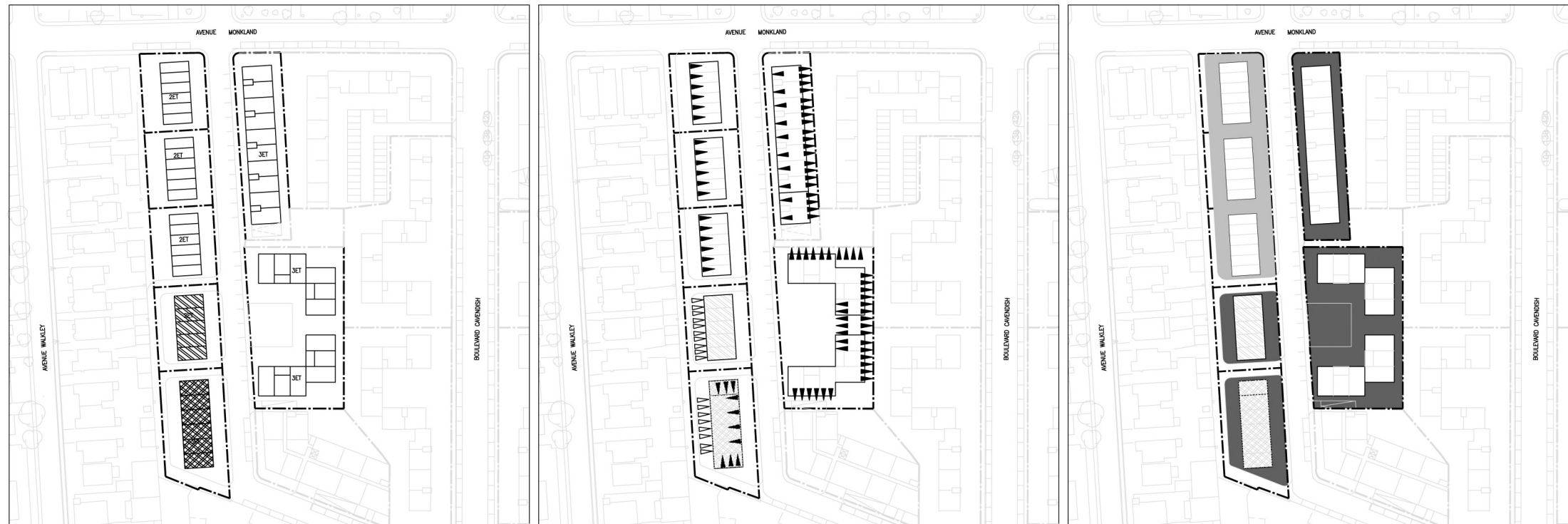

1. Units

2. Parking and Circulation

3. Openspace and Landscape

Building	Item	Unit (\$/s.m.)	Quantity (s.m.)	Cost (\$)
4.2mSF 2-story	Land	269	2,588	696,172
	Construction	911	1,814	1,653,522
	Landscape	28	1,681	47,267
	<b>Total*</b>			<b>2,756,505</b>
5.4m Duplex	Land	269	933	250,977
	Construction	837	648	542,542
	Landscape	34	609	20,613
	<b>Total*</b>			<b>936,252</b>
6.0m Triplex	Land	269	1,303	350,507
	Construction	891	1,296	1,154,778
	Landscape	32	871	27,894
	<b>Total*</b>			<b>1,763,156</b>
W 2u	Land	269	1,527	410,763
	Construction	742	2,435	1,806,090
	Landscape	7	715	4,980
	<b>Total*</b>			<b>2,555,108</b>
W 3u	Land	269	2,658	715,002
	Construction	729	2,922	2,131,740
	Landscape	11	1,684	18,869
	<b>Total*</b>			<b>3,295,453</b>
<b>Total</b>				<b>11,306,474</b>

4. Overall alternative cost

\* : Including Overhead & Profit (15%).

Legend	Type of Units	Number of Units	Density of Each Block	FAR of Each Block
[White Box]	4.2m SF	18		
[Diagonal Lines]	5.4m Duplex	10	95	0.83
[Cross-hatch]	6m Triplex	18		
[White Box]	Walk Up(2U/Floor)	29		
[White Box]	Walk Up(3U/Floor)	36	155	1.28
<b>Total Number of Units</b>		<b>111</b>		
<b>Total Density(units/ha.)</b>		<b>123</b>		
<b>FAR</b>		<b>1.04</b>		

Legend	Type of Units	Parking	
		Indoor ■	Outdoor □
[White Box]	4.2m SF	18	
[Diagonal Lines]	5.4m Duplex	4	6
[Cross-hatch]	6m Triplex	10	8
[White Box]	Walk Up(2U/Floor)	29	
[White Box]	Walk Up(3U/Floor)	36	
<b>Total Number of Parking</b>		<b>111</b>	

Legend	Type of Units	Openspace(m <sup>2</sup> )	
		Private ■	Public ■
[White Box]	4.2m SF	1570	
[Diagonal Lines]	5.4m Duplex	390	
[Cross-hatch]	6m Triplex	560	
[White Box]	Walk Up(2U/Floor)	715	
[White Box]	Walk Up(3U/Floor)	1680	
<b>Total Area (m<sup>2</sup>)</b>		<b>4915</b>	

Cost per dwelling unit\* (\$)

Dwelling	Land	Construction	Landscape	Total**	
4.2mSF 2-story	29,940	90,203	2,402	140,927	
5.4m Duplex	U	20,078	38,015	1,649	68,703
	L	30,117	68,289	2,474	116,012
6.0m Triplex	19,473	62,358	1,550	95,888	
W 2u	13,692	59,393	166	84,239	
W 3u	19,861	57,263	524	89,295	

\* : Inner unit.

\*\* : Including Overhead & Profit (15%).

**Planning Options-4 : Zipper Lot and 5.4m Width Triplex**

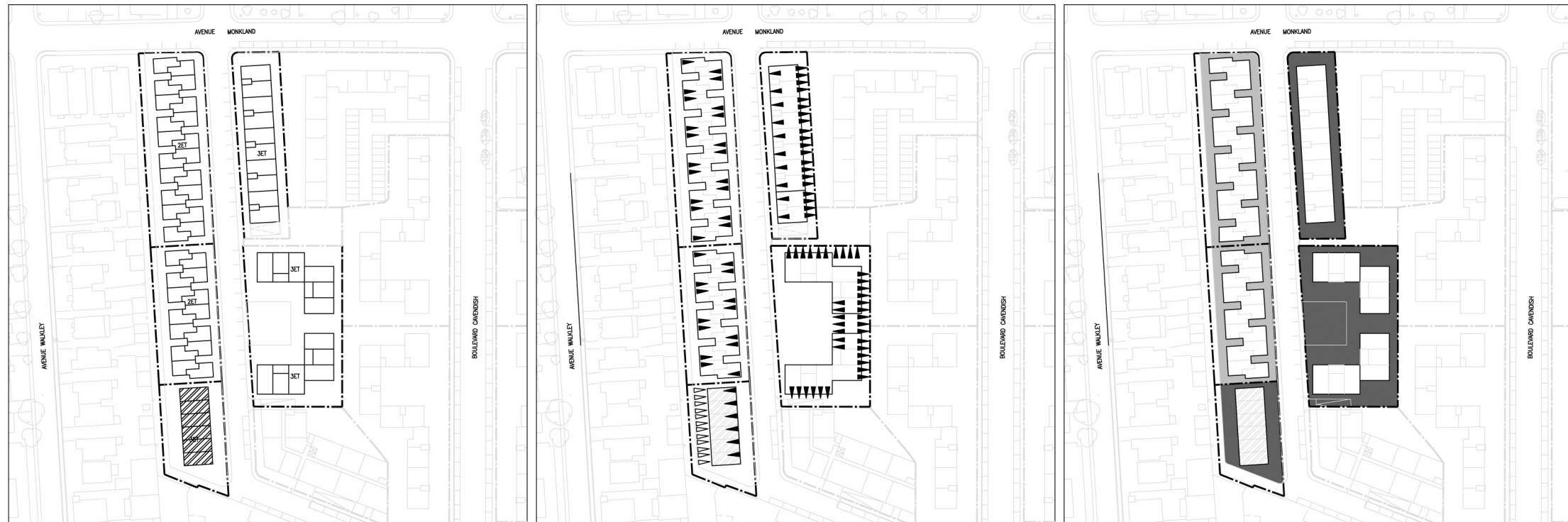

1. Units

2. Parking and Circulation

3. Openspace and Landscape

Building	Item	Unit (\$/s.m.)	Quantity (s.m.)	Cost (\$)
Zipper Lot	Land	269	3,678	989,382
	Construction	1,100	3,580	3,939,976
	Landscape	30	1,888	56,558
	Total*			5,733,803
5.4m Triplex	Land	269	1,135	305,315
	Construction	924	1,166	1,077,834
	Landscape	28	746	20,633
	Total*			1,614,349
W 2u	Land	269	1,527	410,763
	Construction	742	2,435	1,806,090
	Landscape	7	715	4,980
	Total*			2,555,108
W 3u	Land	269	2,658	715,002
	Construction	729	2,922	2,131,740
	Landscape	11	1,684	18,869
	Total*			3,295,453
<b>Total</b>				<b>13,287,199</b>

4. Overall alternative cost

\* : Including Overhead & Profit (15%).

Legend	Type of Units	Number of Units	Density of Each Block	FAR of Each Block
[White Box]	Zipper Lot	34	108	1
[Hatched Box]	5.4m Triplex	18		
[White Box]	Walk Up(2U/Floor)	29	155	1.28
[White Box]	Walk Up(3U/Floor)	36		
Total Number of Units		119		
Total Density(units/ha.)		132		
FAR		1.13		

Legend	Type of Units	Parking	
		Indoor ■	Outdoor □
[White Box]	Zipper Lot	34	
[Hatched Box]	5.4m Triplex	10	8
[White Box]	Walk Up(2U/Floor)	29	
[White Box]	Walk Up(3U/Floor)	36	
Total Number of Parking		119	

Legend	Type of Units	Openspace(m <sup>2</sup> )	
		Private ■	Public ■
[White Box]	Zipper Lot	1600	
[Hatched Box]	5.4m Triplex	525	
[White Box]	Walk Up(2U/Floor)	715	
[White Box]	Walk Up(3U/Floor)	1680	
Total Area (m <sup>2</sup> )		4520	

Cost per dwelling unit\* (\$)

Dwelling	Land	Construction	Landscape	Total**
Zipper Lot	26,732	113,444	1,441	162,860
5.4m Triplex	16,962	58,183	1,146	87,735
W 2u	13,692	59,393	166	84,239
W 3u	19,861	57,263	524	89,295

\* : Inner unit.

\*\* : Including Overhead & Profit (15%).

**Planning Option-5 : 6m Wide Triplex and 5.4m Wide Duplex**



1. Units

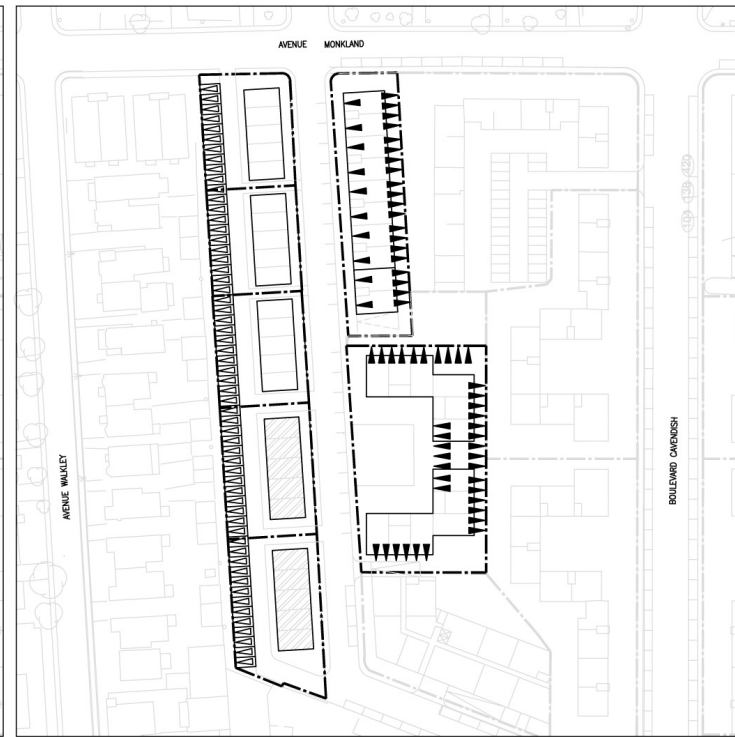

2. Parking and Circulation

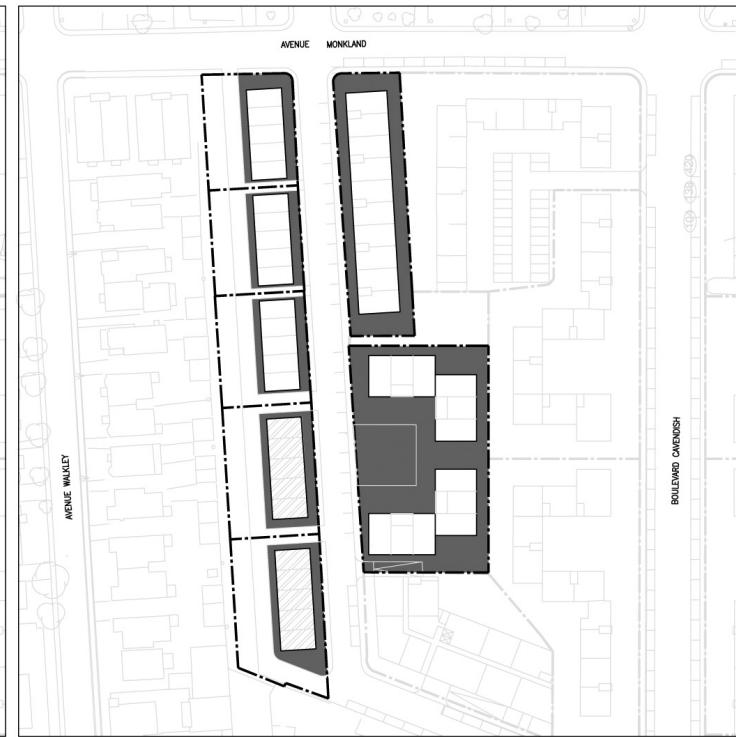

3. Openspace and Landscape

Building	Item	Unit (\$/s.m.)	Quantity (s.m.)	Cost (\$)
5.4m Duplex	Land	269	2,617	703,973
	Construction	837	1,944	1,627,626
	Landscape	28	1,645	46,095
	<b>Total*</b>			<b>2,734,348</b>
6.0m Triplex	Land	269	2,200	591,800
	Construction	883	1,440	1,270,818
	Landscape	26	1,480	39,210
	<b>Total*</b>			<b>2,187,102</b>
W 2u	Land	269	1,527	410,763
	Construction	742	2,435	1,806,090
	Landscape	7	715	4,980
	<b>Total*</b>			<b>2,555,108</b>
W 3u	Land	269	2,658	715,002
	Construction	729	2,922	2,131,740
	Landscape	11	1,684	18,869
	<b>Total*</b>			<b>3,295,453</b>
<b>Total</b>				<b>10,772,011</b>

4. Overall alternative cost

\* : Including Overhead & Profit (15%).

Legend	Type of Units	Number of Units	Density of Each Block	FAR of Each Block
	5.4m Duplex	30	124	0.85
	6m Triplex	30		
	Walk Up(2U/Floor)	29	155	1.28
	Walk Up(3U/Floor)	36		
Total Number of Units		125		
Total Density(units/ha.)		139		
FAR		1.05		

Legend	Type of Units	Parking	
		Indoor ■	Outdoor □
	5.4m Duplex	30	
	6m Triplex	30	
	Walk Up(2U/Floor)	29	
	Walk Up(3U/Floor)	36	
Total Number of Parking		125	

Legend	Type of Units	Openspace(m <sup>2</sup> )	
		Private ■	Public ■
	5.4m Duplex	545	
	6m Triplex	485	
	Walk Up(2U/Floor)	715	
	Walk Up(3U/Floor)	1680	
Total Area (m <sup>2</sup> )		3425	

Cost per dwelling unit\* (\$)

Dwelling	Land	Construction	Landscape	Total**	
5.4m Duplex	U	18,773	38,015	1,229	66,720
	L	28,159	68,289	1,844	113,036
6.0m Triplex	19,727	41,531	1,307	71,950	
W 2u	13,692	59,393	166	84,239	
W 3u	19,861	57,263	524	89,295	

\* : Inner unit.

\*\* : Including Overhead & Profit (15%).

**Planning Option-6 : More 6m Wide Triplex and Fewer 5.4m Wide Duplex**

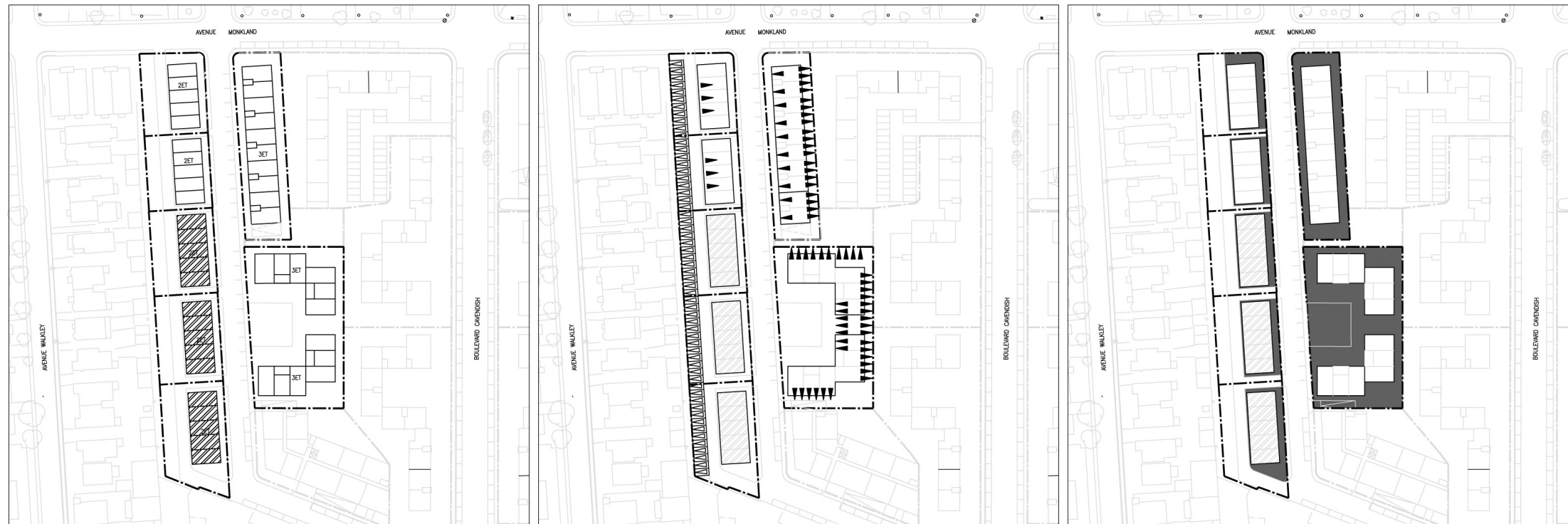

1. Units

2. Parking and Circulation

3. Openspace and Landscape

Building	Item	Unit (\$/s.m.)	Quantity (s.m.)	Cost (\$)
5.4m Duplex	Land	269	1,747	470,010
	Construction	837	1,296	1,085,084
	Landscape	26	1,099	30,546
	<b>Total*</b>			<b>1,823,486</b>
6.0m Triplex	Land	269	3,085	829,862
	Construction	883	2,160	1,906,227
	Landscape	28	2,005	55,458
	<b>Total*</b>			<b>3,210,279</b>
W 2u	Land	269	1,527	410,763
	Construction	742	2,435	1,806,090
	Landscape	7	715	4,980
	<b>Total*</b>			<b>2,555,108</b>
W 3u	Land	269	2,658	715,002
	Construction	729	2,922	2,131,740
	Landscape	11	1,684	18,869
	<b>Total*</b>			<b>3,295,453</b>
<b>Total</b>				<b>10,884,326</b>

4. Overall alternative cost

\* : Including Overhead & Profit (15%).

Legend	Type of Units	Number of Units	Density of Each Block	FAR of Each Block
	5.4m Duplex	20	134	0.94
	6m Triplex	45		
	Walk Up(2U/Floor)	29	155	1.28
	Walk Up(3U/Floor)	36		
Total Number of Units		130		
Total Density(units/ha.)		144		
FAR		1.1		

Legend	Type of Units	Parking	
		Indoor	Outdoor
	5.4m Duplex	6	14
	6m Triplex		45
	Walk Up(2U/Floor)	29	
	Walk Up(3U/Floor)	36	
Total Number of Parking		130	

Legend	Type of Units	Openspace(m <sup>2</sup> )	
		Private	Public
	5.4m Duplex	310	
	6m Triplex	500	
	Walk Up(2U/Floor)	715	
	Walk Up(3U/Floor)	1680	
Total Area (m <sup>2</sup> )		3205	

Cost per dwelling unit\* (\$)

Dwelling	Land	Construction	Landscape	Total**	
5.4m Duplex	U	18,800	38,015	1,222	66,743
	L	28,201	68,289	1,833	113,071
6.0m Triplex	18,441	41,531	1,232	70,385	
W 2u	13,692	59,393	166	84,239	
W 3u	19,861	57,263	524	89,295	

\* : Inner unit.

\*\* : Including Overhead & Profit (15%).

Option-1 (Original Design)

**Advantage ----** In option1, each unit has its own private backyard and the area of private open space is the biggest among the six options. Another appealing point in option1 is all units, except for the walkup units, are single family homes. This type of housing will provide a comfortable living environment by reducing disturbance from other units.

**Disadvantage -** In option1, although single family housing will create a relatively comfortable living environment, the disadvantage it brings out is also obvious. The density in option1 is the lowest and cost for the units are the most expensive among the six options. Since there are only two types of housing, single family unit and walkup units, the range of unit choices is narrow. Another disadvantage is that there is no parking garage in the single family units. Outdoor parking is unappealing in winter.

Option-2

**Advantage ----** In option 2, because the overall units number is increased by adding the 5.4m wide triplexs, the density is increased accordingly. This change will help to decrease the cost of triplex unit. So, compared with option1, three types of units are provided in option 2 with lower price. All parking solutions for 4.8m wide single family units are indoor parking.

**Disadvantage -** In option2, the triplexs help to decrease the cost of unit and increase the density, however, the units in the triplexs will sacrifice the private open space. Especially, the units in upper floor will not have space for outdoor activities. Since more parking space is needed. Because of the increased units number, some of the parking solution for the triplexs is outdoor parking in the backyard. So some of green space will be lost.

Option-3

**Advantage ----** In option 3, the advantage is that there are more types of unit with different cost to meet range of potential buyers' need. More choices are provided in option3. There are five types of units, 4.2m SF, 5.4m duplex, 6.0m triplex, and the other two kinds of walkup units. The cost ranges from \$140,927 to \$68,703 to meet people with different. Another appealing advantage is most of parking solution is indoor.

**Disadvantage -** Option 3 has the same weakness as the option 2. Although the density and units number are increased greatly, the units in triplexs and duplex will sacrifice some quality of living environment, such as losing the backyard. Especially, the units in upper floor will not have space for outdoor activities. Since more parking space is needed because of increase of units number, some of the parking solution for triplexs and duplex is outdoor parking in the backyard. So more greenspace area will be decreased.

Option-4

**Advantage ----** A new type of unit, zipper lot, is introduced in option 4. The advantage is the zipper lot can accommodate more units than the regular lot, and all units are single family house without sacrificing the density. The area of zipper lot unit is bigger than that of other types of units. In option 4, there are other three types of units except of zipper lot units. Most of parking solution in option 4 is indoor parking.

**Disadvantage -** The weakness of option 4 is the private open space of zipper lot is much less than that of the 4.2m SF and 4.8m SF, although zipper lot unit is single family home. This is because the zipper lot units take up more ground area floor, as a result it affects the area of greenspace. The second disadvantage is the cost of zipper lot unit is the highest, because the architectural area of zipper lot unit is bigger than any other type of single family unit.

Option-5

**Advantage ----** In option 5, since all the units are duplexs and triplexs, the density and total unit number are increased further. The cost of each type unit is decreased greatly, which ranges from 113,036 to 66,720. The cost is the most appealing point in the option 5.

**Disadvantage -** The disadvantage of option 5 is obvious. High density will lead to sacrifice the quality of the living environment. First, the unit in plexs is less comfortable than that in single family house. Second, the unit in the duplex or triplex will not have private open space for outdoor activity. Third, because more parking space is needed, the lane and parking lot take up more green space.

Option-6

**Advantage ----** Based on the option 5, more 6.0m wide triplexs replace the 5.4m wide duplexs, so the density and total unit number are increased further. And the cost of 6.0m wide triplex unit is lower than that in option 5. The cost of all the units ranges from \$113,071 to \$66,743. The cost is the most appealing point in the option 6.

**Disadvantage -** The option 6 has the similar disadvantage as the option 5. High density will lead to sacrifice the quality of living environment. First, the unit in plexs is less comfortable than that in single family house. Second, the unit in the duplex or triplex will not have private openspace for outdoor activity. Third, because more parking space is needed, the lane and parking lot take up more greenspace.

Table of Units Type, Units Number and Density of Six options

	4.2m SF	4.8m SF	5.4m Duplex	5.4m Triplex	6m Triplex	Zipper Lot	Walk Up (two units per floor)	Walk Up (three units per floor)	Total Units Number	Total Density
Option-1		36					53		89	99
Option-2		25		15			29	36	105	116
Option-3	18		10		18		29	36	111	123
Option-4				18		34	29	36	119	132
Option-5			30		30		29	36	125	139
Option-6			20		45		29	36	130	144



Several design principles inspired the conception of the proposed homes. They all aim at creating affordable housing that will be acceptable by, and suitable to, the needs of the anticipated buyers as well as fit with the neighborhood's character. In order to reduce cost we have adapted several cost reduction measures that were reflected in all the proposed buildings.

Reduced size was a key feature in all the designs. Smaller homes are at times harder to design than larger ones, since one tries to avoid the appearance of cramped space. What we tried to do is to introduce large front and back openings in order to increase the amount of natural light that will help create a sense of space. Another strategy was to locate the stairs along the longitudinal wall, to thereby not block the core area of the unit. A measure that helped to alleviate the sense of smallness was to have an open plan concept. Combining spaces (primarily on lower levels) will not only make the home feel larger, but will result in cost savings as less partitions are built.

Having a simple shape will contribute to lowering cost and to reducing construction time as well. The tendency is often to assume that one needs to complicate the building form in order to make it appealing. Affordable homes can be simple, yet elegant at the same time. A complex home with numerous corners will affect the cost of the foundation, the walls, and the roof. Complex roofs may also be responsible for poor energy management and, therefore, we tried to avoid them in the Benny Farm project. A simple shaped design will also take less time to construct, which will result in lower cost.

Building taller rather than wider was another approach to cost reduction. Two big-ticket items in the cost of housing are commonly land and infrastructure. Building vertically rather than horizontally can contribute to reducing the building cost of these items. In addition, more homes are using the same foundation, which also constitutes a cost savings. By selecting the proper roof angle, attics can be introduced and the space finished at the outset or at a later date. The other advantage of building taller is contribution to better energy management of the building. Since heat rises, the upper floors and the attic will require less energy to keep warm. Another advantage that taller buildings provide has to do with urban appearance and human scale. When properly proportioned, taller buildings will render a much nicer and comfortable scale to the street.

Joining units was another cost reduction measure. Both NDG and the Benny Farm area have well-established traditions of row housing, which we followed. The savings will be numerous. Land and infrastructure are key features. If the homes are sold as condominiums (those smaller than 5.4 m wide), one sewer cut connection can be done for the entire row, thereby saving more. The cost of side walls can also be reduced. As far as energy management is concerned, by joining units, one can assure that heat lost in one unit will be gained by the unit next door. Inner units will therefore be highly efficient.

When joining units to create a row, we have avoided the creation of a very long row. Such a design will foster repetition and monotony, we feared. It will also require the residents to pass through their units if they want to reach their backyard rather than approaching the rear from the outside. We also attempted to offer choices with regard to the parking garages. Narrow homes with a number of successive garage doors are not appealing and we therefore attempted to avoid them.

Suitability between people's demographic and economic status and the offered homes was another key aspect in the units' design. We considered both the entire project and the units themselves as a flexible system. Reversibility was a principal guide in all our units' design. The homes can all be constructed with indoor or outdoor parking. Their interior is also flexible to allow the kitchen to be placed at the front or the rear of the unit. As society becomes more diverse, one can expect to see single-person and family households willing to buy units in the same building. We therefore suggested flexibility of interior layouts, and that a choice of building sub-components be offered to buyers. In the six-meter-wide triplex and the three-unit walk-up a buyer can purchase two floors, or adjacent units rather than one. The space can easily be combined to become a single dwelling. We also recommend that arrangements will be made to house disabled people and choices of suitable building components be made for them.

Leaving some spaces and/or components for buyer completion was another cost reduction strategy that we employed in the unit design. Basements or attics can be left unpartitioned and can be completed when means become available. The work can be done by the occupants themselves or by hired contractors. Recent years saw the growth of home renovation centres. Components also became easier to install due to the simplification in their manufacturing process. As a result, one needs to adopt an evolutionary approach to the construction of a home and see it as an ongoing process that might take years and be fitted to the occupants' life cycle changes. In our cost calculation we also demonstrated how much can be saved if certain areas in the house were to be left unfinished.

In all the units, in order to save on plumbing cost, we have attempted to place the wet functions in close proximity to each other. When wet functions exist on other floors, we attempted to stack them vertically. Some bathrooms can also be left un- or partially-finished for later completion.

Despite the fact that we did not provide construction documents, we strongly recommend that attention be paid to the choice of good basic construction materials. Affordable homes need to be properly constructed in order to prevent future investment in maintenance and upgrade. Cost reduction can be achieved through reduction or better management of space rather than lowering quality standards. Alternative exterior wall sections that contribute to better energy management, while remaining cost-effective, must be explored.

Paying attention to the unit's "curb appeal" was another key aspect in our design. Affordability need not imply cheap looking. By creating simple design, yet articulating it with features like decks and balconies, one can also introduce elegance. Colour can also add appeal to a project when carefully chosen. We therefore recommend that attention be paid to stressing individual units by using different shades, or even by allowing the occupants to select them. Attention should also be paid to streetscape and to the landscape in front of each unit in order to further accentuate the dwelling's appeal.

	ROW HOUSE: 4.2M	ROW HOUSE: 4.8M	ZIPLLOT	DUPLEX: 5.4M	TRIPLEX: 5.4M	TRIPLEX: 6.0M	WALKUP: 2 UNITS/F	WALKUP: 3 UNITS/F
Basement	<p>Finished Unfinished Garage</p>	<p>Finished Unfinished Garage</p>	<p>Garage Unfinished</p>	<p>Finished Unfinished Garage</p>	<p>Unfinished Garage</p>	<p>Finished Garage 1 Garage 2</p>	<p>Garage</p>	<p>Garage</p>
Ground Floor								
Second Floor							<p>(Typical Floor)</p>	<p>(Typical Floor)</p>
Third Floor								
Attic	<p>Finished Unfinished</p>	<p>Finished Unfinished</p>	<p>Finished Unfinished</p>	<p>Finished Unfinished</p>	<p>Finished Unfinished</p>	<p>Finished Unfinished</p>		
Cost								

**ROW HOUSE: 4.2M WIDE**

**FLOOR PLANS 1:200**

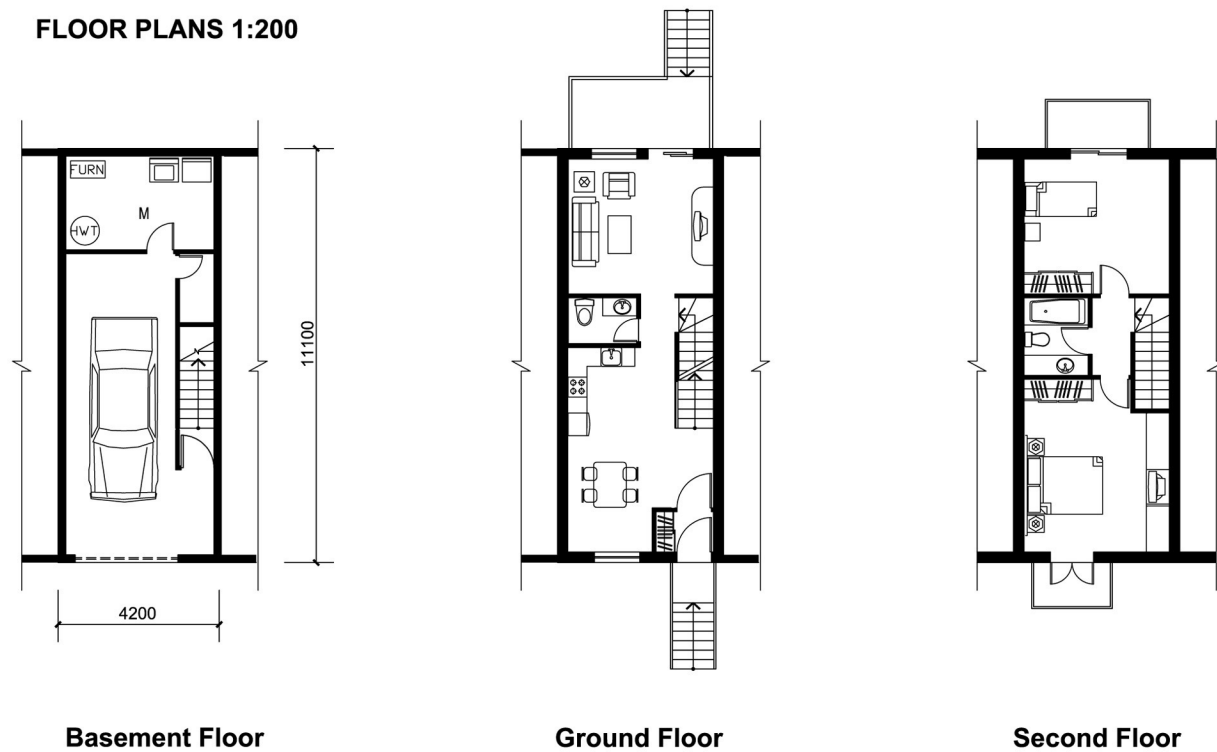

**Basement Floor**

**Ground Floor**

**Second Floor**



**TYPE OF UNIT**

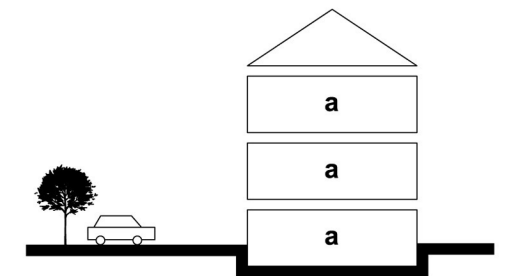

**UNIT INFORMATION**

Area	Basement	46.2 m <sup>2</sup>
	First Floor	46.2 m <sup>2</sup>
	Second Floor	46.2 m <sup>2</sup>
	<b>Total</b>	<b>138.6 m<sup>2</sup></b>

**SECTION/ELEVATION 1:200**



**A-A Section**

**Front Elevation**

**Rear Elevation**

**PLANNING OPTION**

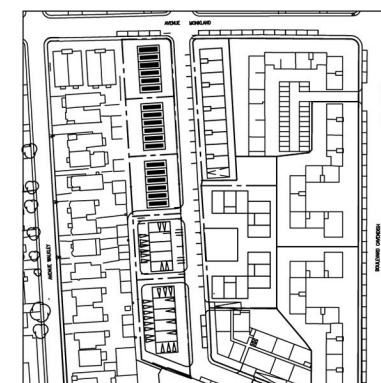

**Option 3**

**COST ANALYSIS**

Item	Unit (\$/s.m.)	Quality (s.m.)	Cost (\$)
Land	269	111	29,940
Construction	895	101*	90,203
Landscape**	39	61	2,402
<b>Total**</b>			<b>140,927</b>

\* : Living area.  
 \*\* : Including driveway system, sidewalk system, wood deck for single family, and grass.  
 \*\*\* : Including Overhead & Profit (15%); inner unit, all floors finished.

**Construction Cost Reduction Alternatives**

	Inner Unit		End Unit*	
	Cost (\$)	Saving (%)	Cost (\$)	Saving (%)
All Floors Finished	90,203	0.00	95,181	0.00
Basement Unfinished	85,596	5.11	90,460	4.96
Second Floor Unfinished	82,887	8.11	87,865	7.69
Basement & Second Floor Unfinished	78,280	13.22	83,144	12.65

\* : For the townhouse/rowhouse, the end unit costs more on the land and the landscape as it does on the construction, compared with the inner unit.

**ROW HOUSE: 4.8M WIDE**

**FLOOR PLANS 1:200**

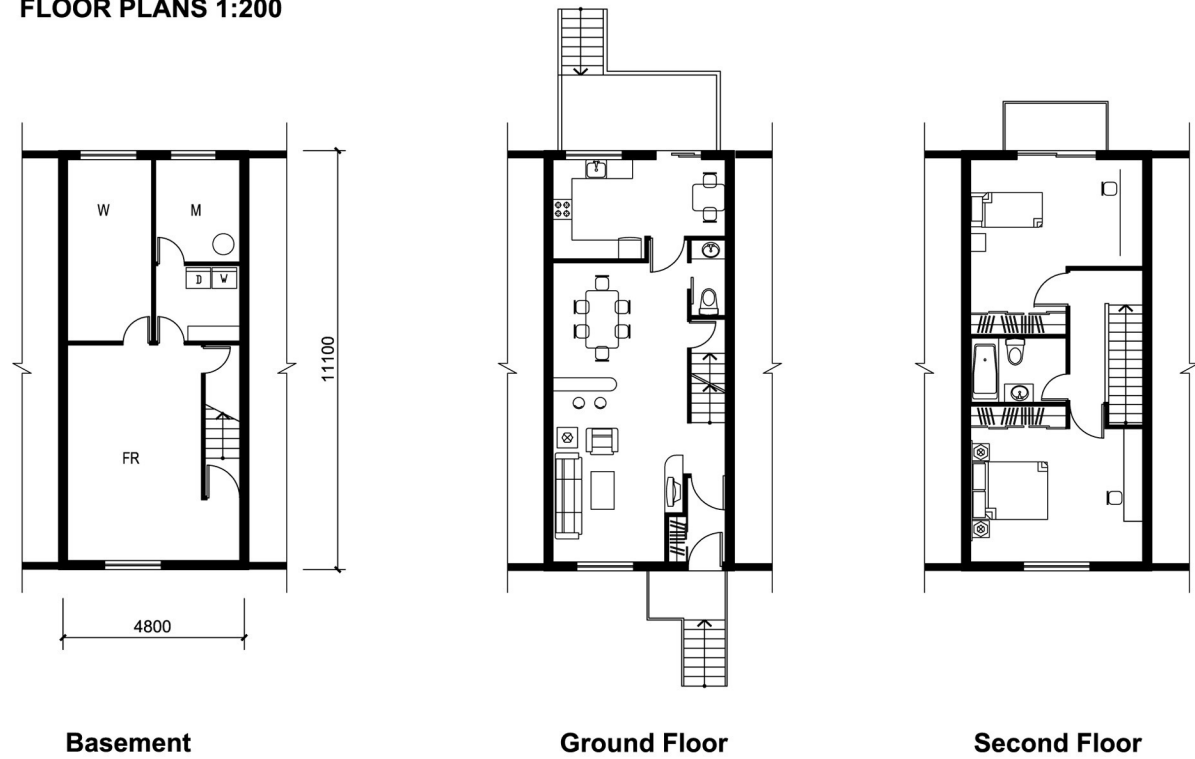

**TYPE OF UNIT**

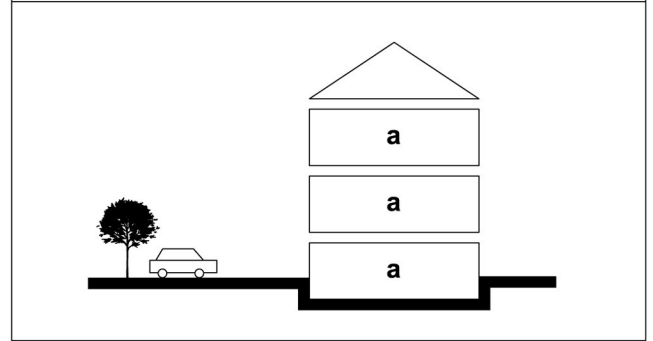

**UNIT INFORMATION**

Area	Basement	52.8 m <sup>2</sup>
	First Floor	52.8 m <sup>2</sup>
	Second Floor	52.8 m <sup>2</sup>
	<b>Total</b>	<b>158.4 m<sup>2</sup></b>

**SECTION/ELEVATION 1:200**



**PLANNING OPTION**

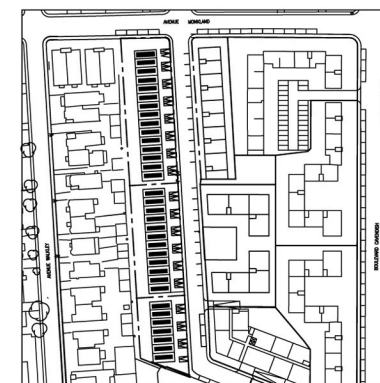

**COST ANALYSIS**

Item	Unit (\$/s.m.)	Quality (s.m.)	Cost (\$)
Land	269	127	34,217
Construction	810	115*	93,202
Landscape**	35	70	2,452
<b>Total***</b>			<b>149,352</b>

\* : Living area.  
 \*\* : Including driveway system, sidewalk system, wood deck for single family, and grass.  
 \*\*\* : Including Overhead & Profit (15%); inner unit, all floors finished.

**Construction Cost Reduction Alternatives**

	Inner Unit		End Unit*	
	Cost (\$)	Saving (%)	Cost (\$)	Saving (%)
All Floors Finished	93,202	0.00	98,239	0.00
Basement Unfinished	87,956	5.63	92,870	5.47
Second Floor Unfinished	85,742	8.00	90,779	7.59
Basement & Second Floor Unfinished	80,496	13.63	85,410	13.06

\* : For the townhouse/rowhouse, the end unit costs more on the land and the landscape as it does on the construction, compared with the inner unit.

**ROW HOUSE: ZIPPER LOT**

**FLOOR PLANS 1:200**



**PERSPECTIVE**



**TYPE OF UNIT**

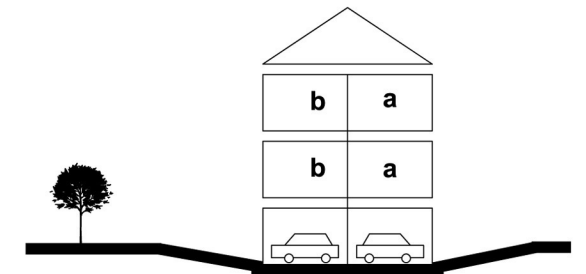

**UNIT INFORMATION**

Area	Basement	44.8 m <sup>2</sup>
	First Floor	44.8 m <sup>2</sup>
	Second Floor	44.8 m <sup>2</sup>
	<b>Total</b>	<b>134.4 m<sup>2</sup></b>

**SECTION/ELEVATION 1:200**



**PLANNING OPTION**

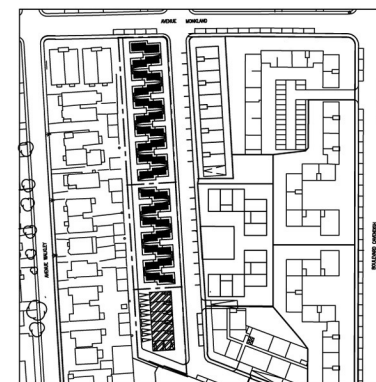

**COST ANALYSIS**

Item	Unit (\$/s.m.)	Quality (s.m.)	Cost (\$)
Land	269	99	26,732
Construction	1077	105*	113,444
Landscape**	31	47	1,441
<b>Total***</b>			<b>162,860</b>

\* : Living area.  
 \*\* : Including driveway system, sidewalk system, and grass.  
 \*\*\* : Including Overhead & Profit (15%); inner unit, all floors finished.

**Construction Cost Reduction Alternatives**

	Inner Unit		End Unit*	
	Cost (\$)	Saving (%)	Cost (\$)	Saving (%)
All Floors Finished	113,444	0.00	123,804	0.00
Basement Unfinished	105,309	7.17	115,216	6.94
Second Floor Unfinished	104,864	7.56	115,224	6.93
Basement & Second Floor Unfinished	96,729	14.73	106,636	13.87

\* : For the Zipper Lot built in a row, the end unit costs more on the land and the landscape as it does on the construction, compared with the inner unit.

DUPLEX: 5.4M WIDE

FLOOR PLANS: 1:200



PERSPECTIVE



TYPE OF UNIT

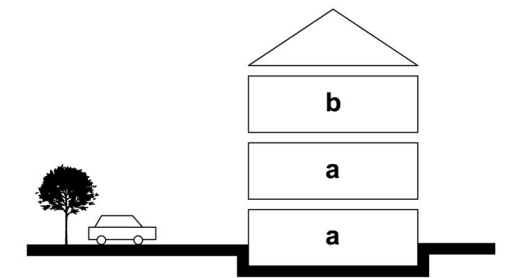

UNIT INFORMATION

Area	Basement	62.6 m <sup>2</sup>
	First Floor	62.6 m <sup>2</sup>
	Second Floor	66.1 m <sup>2</sup>
	<b>Total</b>	<b>191.3 m<sup>2</sup></b>

SECTION/ELEVATIONS: 1:200



PLANNING OPTION

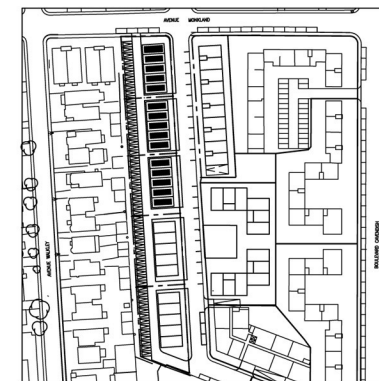

COST ANALYSIS

Item		Unit (\$/s.m.)	Quality (s.m.)	Cost (\$)
Land	U*	269	75	20,078
	L*	269	112	30,117
Construction	U	587	65**	38,015
	L	1,054	65**	68,289
Landscape***	U	34	49	1,649
	L	34	73	2,474
Total****	U			68,703
	L			116,012

\* : Upper unit-second floor; Lower unit- basement and first floor.  
 \*\* : Living area.  
 \*\*\* : Including driveway system, sidewalk system, and grass.  
 \*\*\*\* : Including Overhead & Profit (15%); inner unit, all floors finished.

Construction Cost Alternatives\*

	Inner Unit		End Unit**	
	Cost (\$)	Saving (%)	Cost (\$)	Saving (%)
Second Floor Finished	38,015	0.00	39,986	0.00
Second Floor + Unfinished Attic	40,297	-6.00	42,267	-5.70
Second Floor + Finished Attic	42,008	-10.50	43,979	-9.99

\* : For the upper unit.  
 \*\* : For the duplex, the end unit costs the same on the land and the landscape compared with the inner unit.

TRIPLEX: 5.4M WIDE

FLOOR PLANS: 1:200



PERSPECTIVE



TYPE OF UNIT

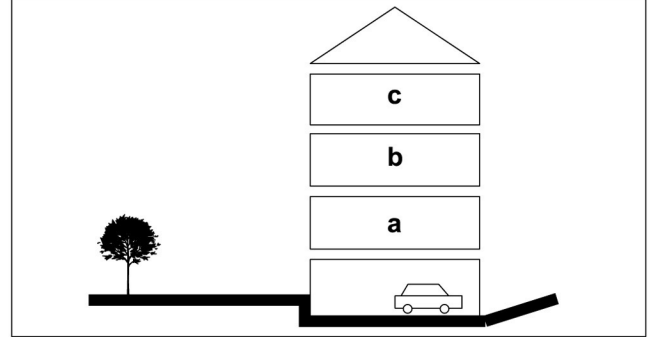

UNIT INFORMATION

Area	Basement	62.6 m <sup>2</sup>
	First Floor	62.6 m <sup>2</sup>
	Second Floor	66.1 m <sup>2</sup>
	Third Floor	66.1 m <sup>2</sup>
	Total	257.4 m <sup>2</sup>

SECTION/ELEVATIONS: 1:200

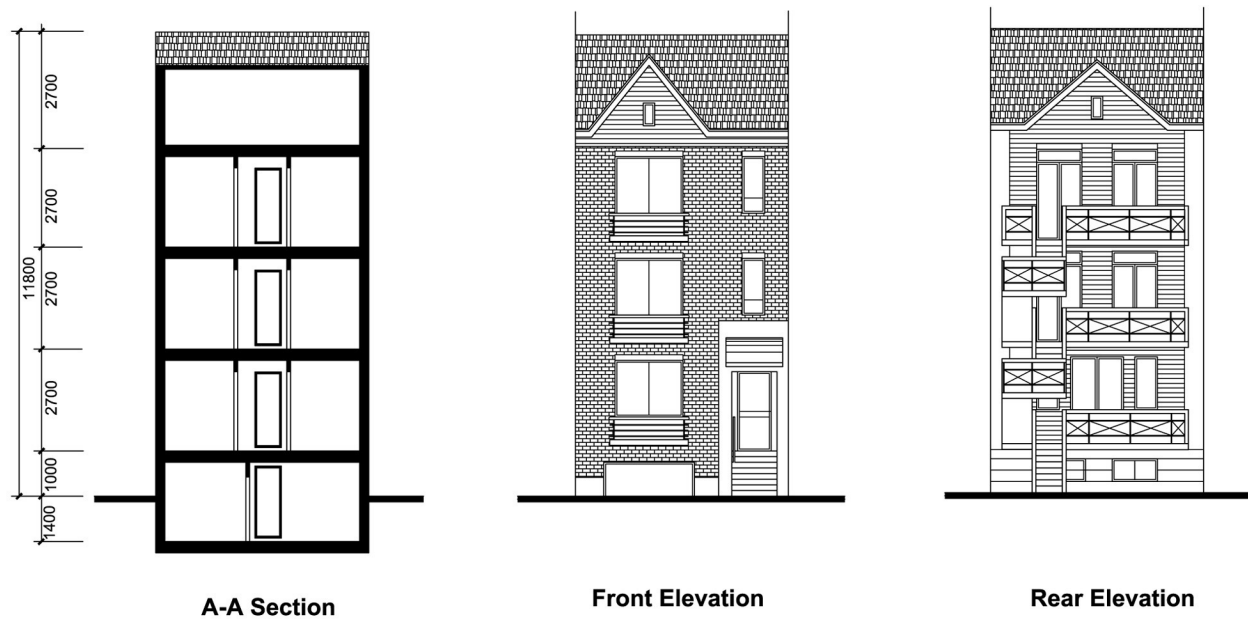

PLANNING OPTION

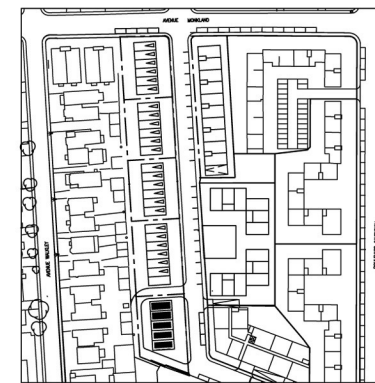

COST ANALYSIS

Item	Unit (\$/s.m.)	Quality (s.m.)	Cost (\$)
Land	269	68	18,292
Construction	898	65*	58,183
Landscape**	35	46	1,631
Total***			89,822

\* : Living area.  
 \*\* : Including driveway system, sidewalk system, and grass.  
 \*\*\* : Including Overhead & Profit (15%); inner unit, all floors finished.

Construction Cost Alternatives

	Cost (\$)	
	Inner Unit	End Unit*
All Floors Finished	58,183	63,273

\* : For the triplex, the end unit costs the same on the land and the landscape compared with the inner unit.

**DUPLEX: 6.0M WIDE - Indoor Parking, End Unit**

**FLOOR PLANS: 1:200**

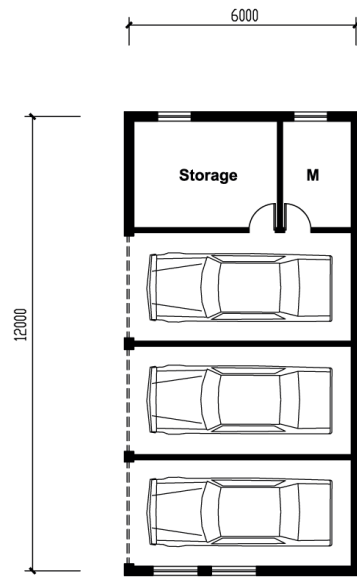

**Basement**

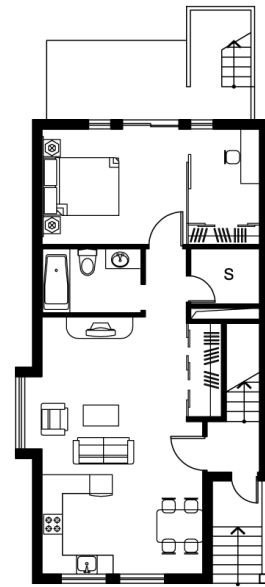

**First Floor**

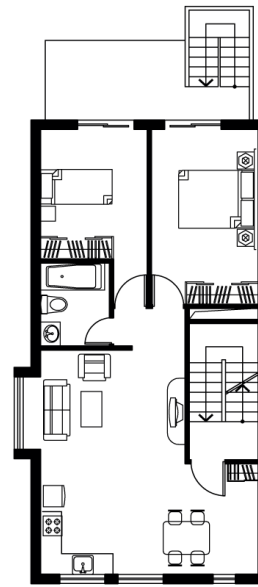

**2nd, 3rd Floor**

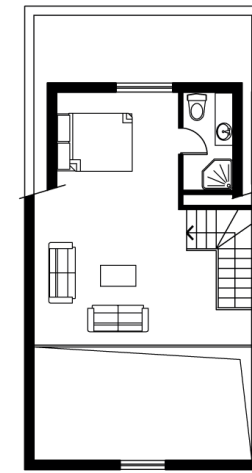

**Attic**

**TYPE OF UNIT**

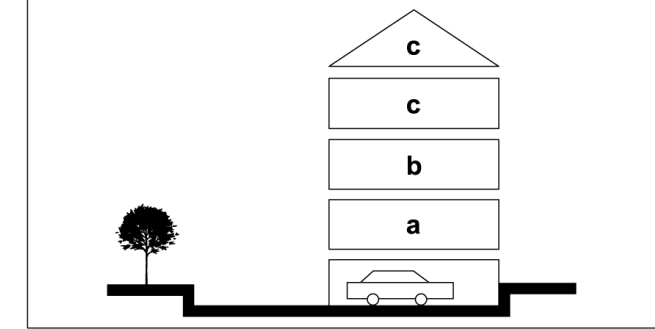

**UNIT INFORMATION**

Area	Basement	73.4 m <sup>2</sup>
	First Floor	74.0 m <sup>2</sup>
	Second Floor	74.5 m <sup>2</sup>
	Third Floor	74.5 m <sup>2</sup>
	Attic	38.2 m <sup>2</sup>
<b>Total</b>		<b>191.3 m<sup>2</sup></b>

**SECTION/ELEVATIONS: 1:200**



**A-A Section**

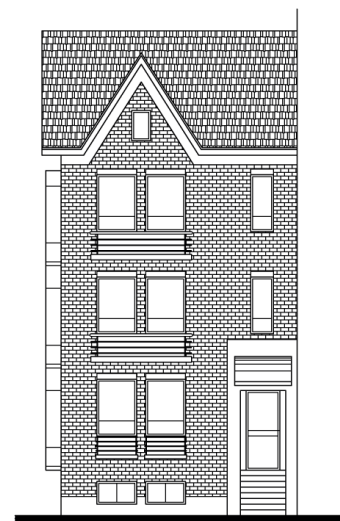

**Front Elevation**



**Rear Elevation**

**PLANNING OPTION**

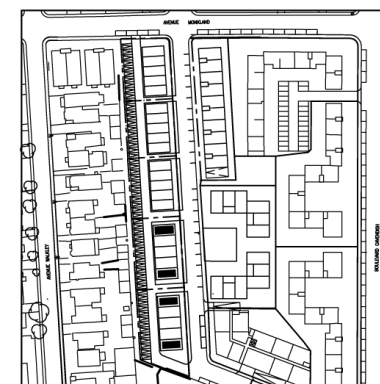

**Option 5**

**COST ANALYSIS**

Item	Unit (\$/s.m.)	Quality (s.m.)	Cost (\$)
Land	269	72	19,473
Construction	866	72*	62,358
Landscape**	32	48	1,550
<b>Total***</b>			<b>95,888</b>

\* : Living area.  
 \*\* : Including driveway system, sidewalk system, and grass.  
 \*\*\* : Including Overhead & Profit (15%); inner unit, all floors finished.

**Construction Cost Alternatives**

	Cost (\$)	
	Inner Unit	End Unit*
All Floors Finished	62,358	67,747

\* : For the triplex, the end unit costs the same on the land and the landscape compared with the inner unit.



**TRIPLEX: 6.0M WIDE - Outdoor Parking, Inner Unit**

**FLOOR PLANS: 1:200**



**PERSPECTIVE**



**TYPE OF UNIT**

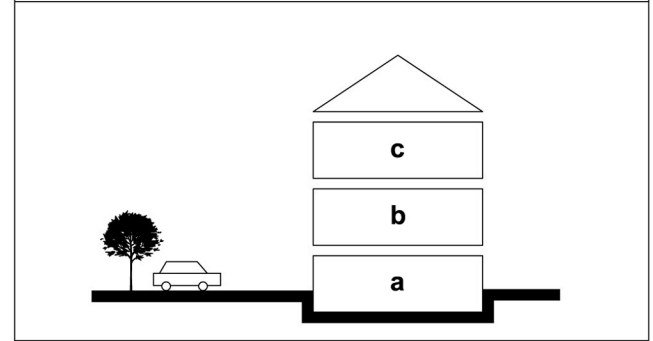

**UNIT INFORMATION**

Area	Basement	73.4 m <sup>2</sup>
	First Floor	72.9 m <sup>2</sup>
	Second Floor	73.4 m <sup>2</sup>
	Third Floor	73.4 m <sup>2</sup>
	<b>Total</b>	<b>293.1 m<sup>2</sup></b>

**COST ANALYSIS**

Item	Unit (\$/s.m.)	Quality (s.m.)	Cost (\$)
Land	269	73	19,727
Construction	577	72*	41,531
Landscape**	26	49	1,307
<b>Total***</b>			<b>71,950</b>

\* : Living area.  
 \*\* : Including driveway system, sidewalk system, and grass.  
 \*\*\* : Including Overhead & Profit (15%); inner unit, all floors finished.

**Construction Cost Alternatives**

	Cost (\$)	
	Inner Unit	End Unit*
All Floors Finished	41,531	43,605

\* : For the triplex, the end unit costs the same on the land and the landscape compared with the inner unit.

**SECTION/ELEVATIONS: 1:200**



**PLANNING OPTION**

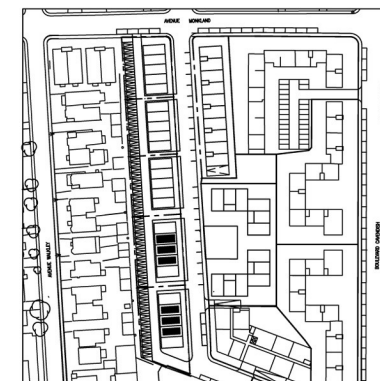

**WALKUP: 2 UNITS/FLOOR**

**FLOOR PLANS: 1:200**

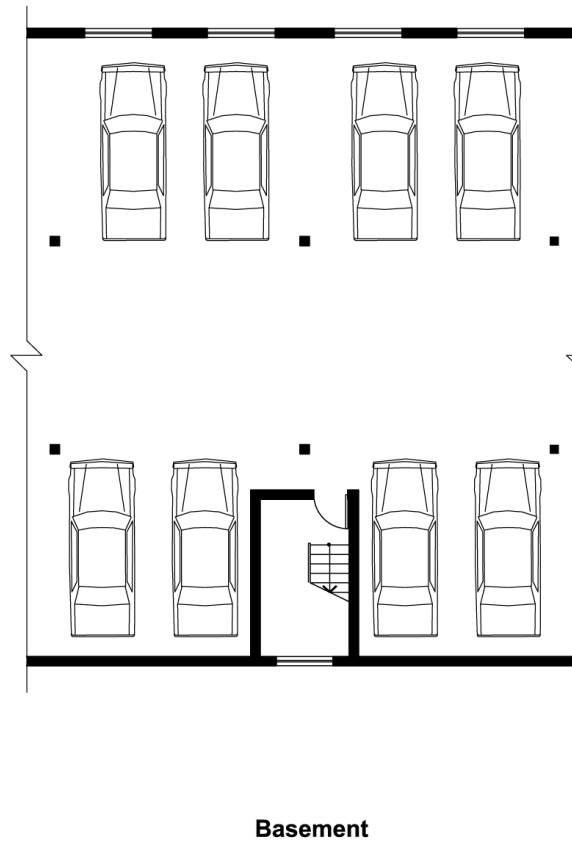
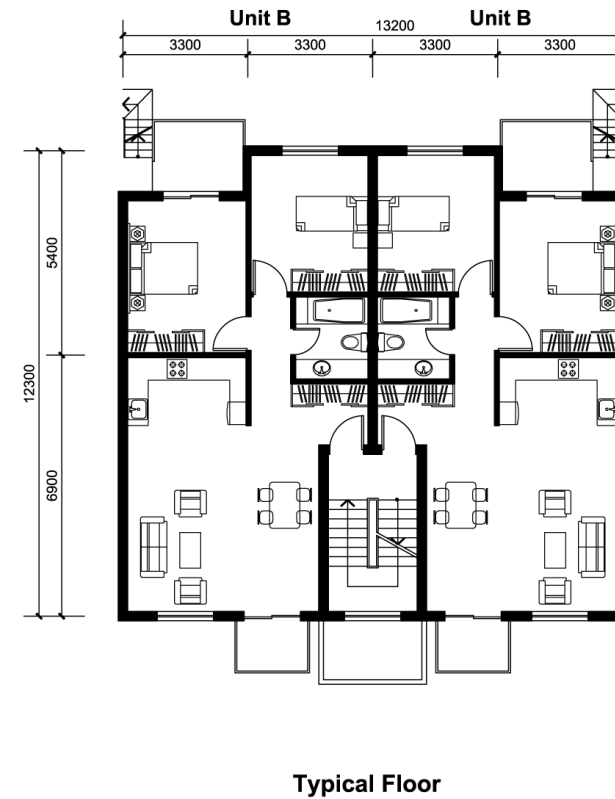
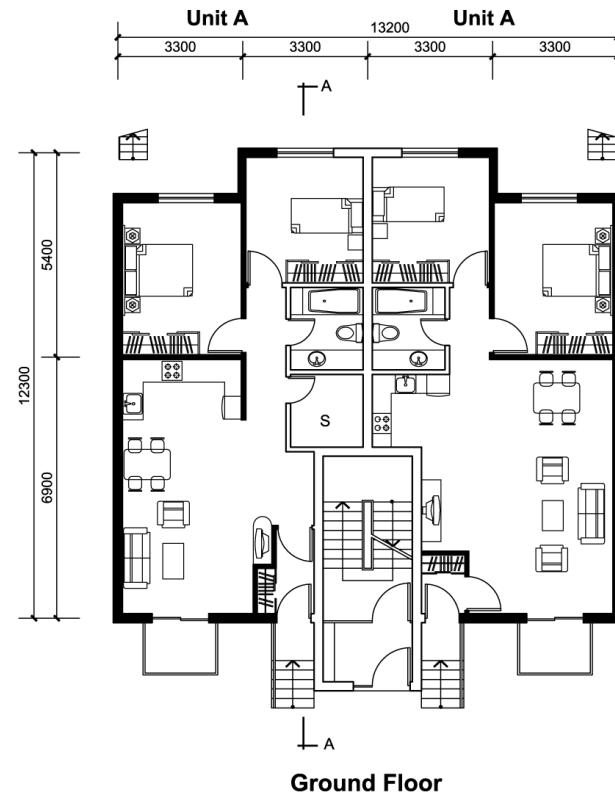

**SECTION/ELEVATIONS: 1:200**

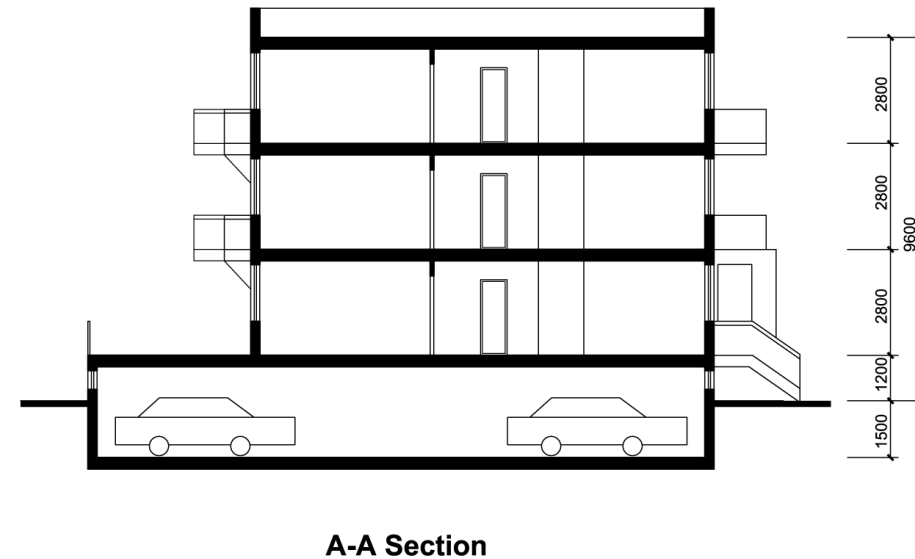
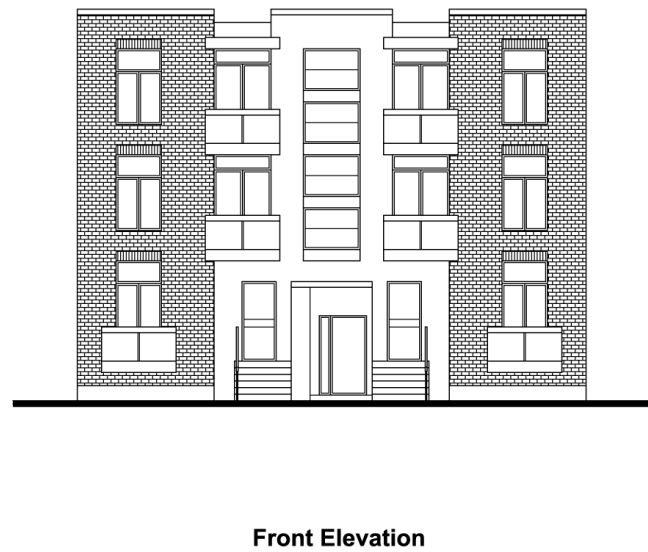

**PLANNING OPTION**

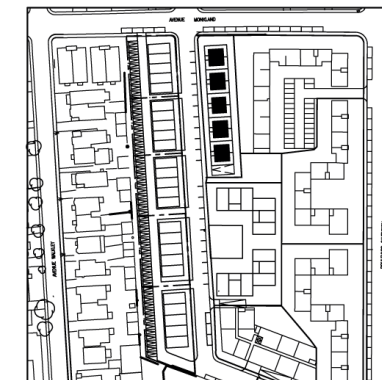

**TYPE OF UNIT**

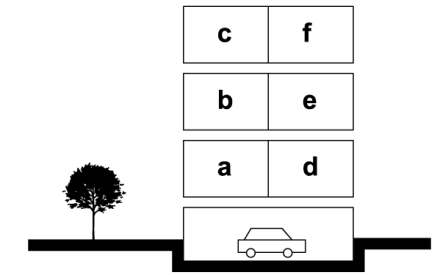

**UNIT INFORMATION**

Area	Unit A	81.6 m <sup>2</sup>
	Unit B	81.6 m <sup>2</sup>
Total		489.6 m <sup>2</sup>

**COST ANALYSIS**

Item	Unit (\$/s.m.)	Quantity (s.m.)	Cost (\$)
Land	269	51	13,692
Construction	732	81*	59,393
Landscape**	7	24	166
<b>Total***</b>			<b>84,239</b>

\* : Living area.  
 \*\* : Including driveway system, sidewalk system, and grass.  
 \*\*\* : Including Overhead & Profit (15%); inner unit, all floors finished.

**Construction Cost Alternatives**

	Cost (\$)	
	Inner Unit	End Unit*
All Floors Finished	59,393	63,443

\* : For the triplex, the end unit costs the same on the land and the landscape compared with the inner unit.

**WALKUP: 3 UNITS/FLOOR**

**FLOOR PLANS: 1:250**

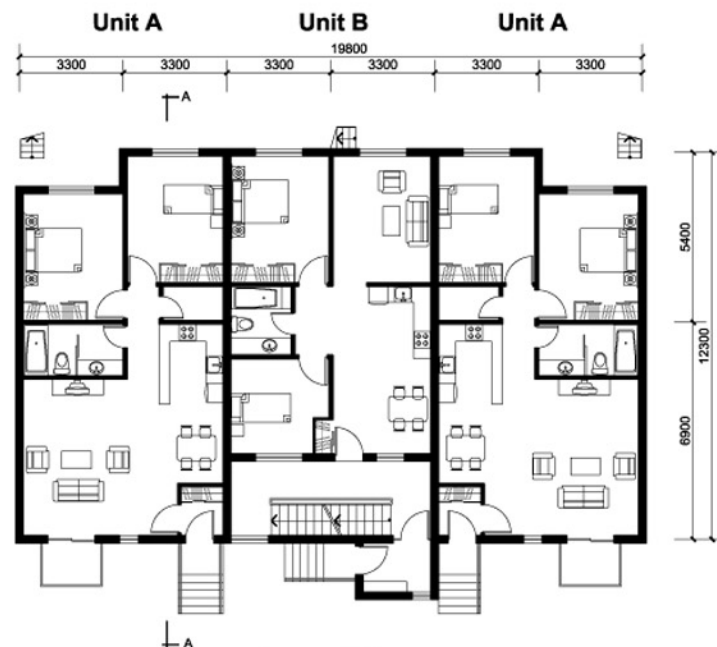

**Ground Floor**

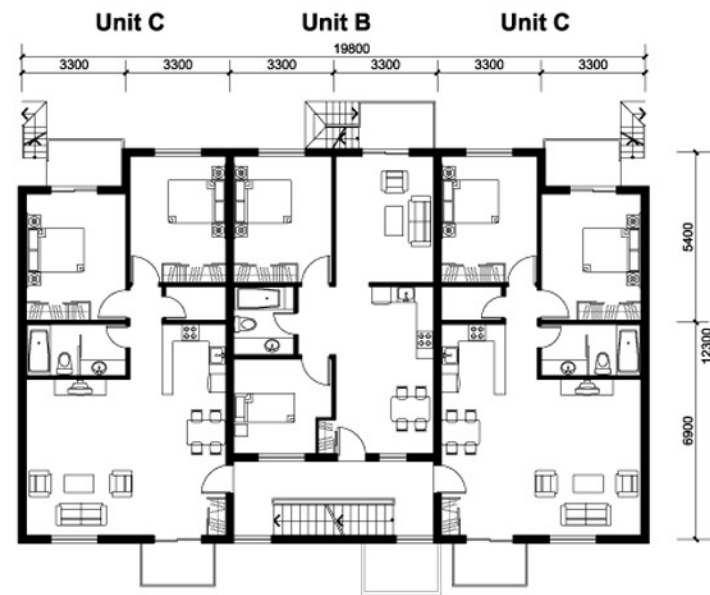

**Typical Floor**

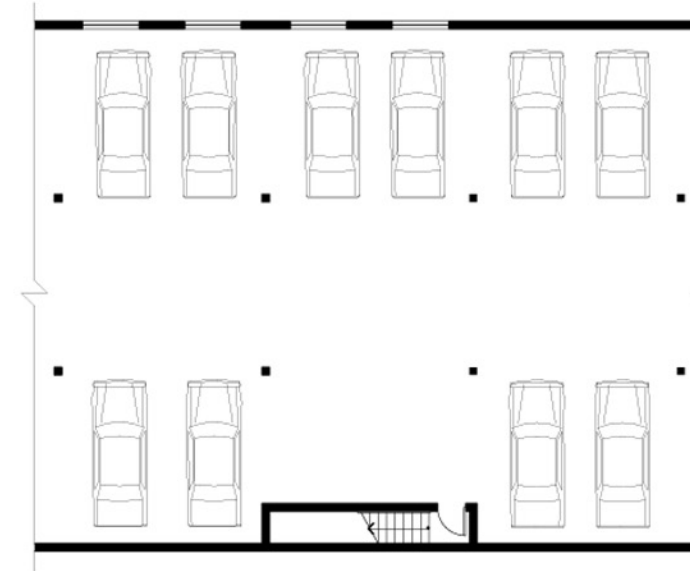

**Basement**

**SECTION/ELEVATIONS: 1:250**



**Front Elevation**

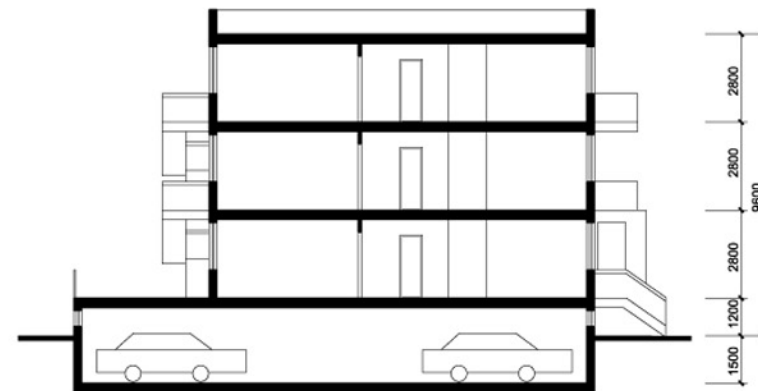

**A-A Section**

**PLANNING OPTION**



**TYPE OF UNIT**

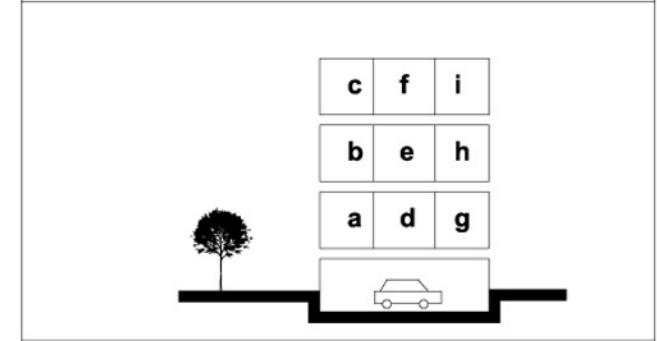

**UNIT INFORMATION**

Area	Unit A	85.8 m <sup>2</sup>
	Unit B	70.1 m <sup>2</sup>
	Unit C	85.8 m <sup>2</sup>
	Total	725.1 m <sup>2</sup>

**COST ANALYSIS**

Item	Unit (\$/s.m.)	Quality (s.m.)	Cost (\$)
Land	269	74	19,861
Construction	705	81*	57,263
Landscape**	11	47	524
Total***			89,295

\* : Living area.  
 \*\* : Including driveway system, sidewalk system, and grass.  
 \*\*\* : Including Overhead & Profit (15%); inner unit, all floors finished.

**Construction Cost Alternatives**

	Cost (\$)	
	Inner Unit	End Unit*
All Floors Finished	57,263	61,167

\* : For the triplex, the end unit costs the same on the land and the landscape compared with the inner unit.

## Conclusions and Recommendations

Design and construction of affordable housing for Benny Farm requires that the initiator follow a process. The process will ensure that the build designs will suit the target population both demographically and economically. At the same time it will ensure that a present and future value be built up for the project as a whole. These studies led us to the drawing of several conclusions.

### Socio-economic Profile

- The large number of single-person households justify considering smaller units. Offering duplexes and triplexes as well as small walk-up units will not only suit the demographic character of potential buyers, but will help reach affordability targets.
- Current indicators point to a population annual income of less than \$50,000. This, once again, poses an affordability challenge that will only be compensated for by increasing the density and by offering small size units.
- There is a substantial pool of renters in the area from which, one can assume, many of the buyers will be drawn. Many of the renters are older—mature households—and some have even saved the necessary down payment.

### Affordability

- Based on the household's income profile in NDG and the Benny Farm area, the potential buyer's income may range from \$24,454 to \$60,000. Depending on the percentage of the down payment, units for these buyers should range in price from \$70,000 to \$200,000, with the majority on lower cost units. It is also expected that a sizeable number of buyers will be single persons with one income.

### Zoning

- One of the most constraining challenges in the project's design is parking. Despite the need to increase density, one parking spot per unit can be maintained. The project is currently well-served by public transit and one would assume that some of the residents will have no car at all.

### Architectural Context

- The mark of a successful infill project lies in the ability to weave it in nicely with the existing context. Great achievements were made by maintaining some of the structures on the site. A similar effort must be made so that the new buildings will be designed in concert with neighboring existing buildings. Aspects that one must pay attention to are the units' typology, setbacks, parking height, exterior materials and features, roofs, doors, and windows. These are the visible and sometimes hidden elements that make old and new look unified.

### Cost Reduction Strategies

- There should be a range of cost-reduction strategies, each contributing to an overall reduction. Yet, the most effective strategies will be those that will reduce width, move from single- to multi-family types, build in groups and have the car parked outdoors.

### Planning Options

- In order to achieve the affordability target, there must be a wider ranger of dwellings than the one offered in the original proposal. More family units must be added. Our Options 2, 3 and 5, which were elaborated above, offer the biggest potential to achieve units with costs as low as \$70,000, which will enable households with lower income to purchase a home.

### Unit Design

- In order to achieve affordability, certain principles must be maintained in the unit design. They are size reduction, simple shape, building taller rather than wider, joining of units, offering a choice of dwelling layout and interior finishes, leaving some spaces unfinished, efficient location of wet functions, good selection of building products and components, and design with a curb appeal.

**Cost Comparison of Different Type of Units**

Type of unit	Planning Option	Comparison	Land			Construction			Landscape			Total Cost (\$)	Affordable for Family with Household Income around***(\$)	
			Cost* (\$)	Unit**(\$/s.m.)	Analysis	Cost* (\$)	Unit**(\$/s.m.)	Analysis	Cost* (\$)	Unit**(\$/s.m.)	Analysis			
<b>4.2m SF 2-story</b>	3		29,940	269	Reduction of the width of the lot	90,203	911	Smaller unit, but the cost per square metre is higher than that of a bigger one	2,402	28	Smaller lot, indoor parking; fewer pavement for both driveway and walkway	140,927	40,430 (Close to MTL Average)	
<b>4.8m SF 2-story</b>	1		34,217	269	More units in a row reduces the consumption of land for the whole building/project, but not for that of an inner or end unit	93,202	816	More units in a row (inner units cost less than end units)	2,452	30		149,352	42,847 (Close to NDG Average)	
	2		34,217	269		93,202	823	Less units in a row (end units cost more than inner units)	2,452	28	Less units in a row: less pavement, which is expensive; more lawn, which is cheaper	149,352	42,847 (Close to NDG Average)	
<b>4.8m SF 3-story</b>	1		34,217	269		149,664	888	More living areas:lower base cost More levels:higher base cost	2,452	29		214,283	61,475 (Close to Assumed Buyer-High)	
<b>Zipper Lot</b>	4		26,732	269	Reduction of the width of the lot at only one end; Make the most use of the depth of the lot	113,444	1,100	Complexity of the layout; More exterior walls and windows	1,441	30	Long walkway leads to the main entrance	162,860	46,722 (Close to NDG Average)	
<b>5.4m Duplex</b>	<b>U</b>	3		20,078	269	Share of the land ownership	38,015	837	Use of attic is an efficient solution compared with a full story	1,649	34	Side and back driveways: more pavement	68,703	19,710 (Lower than B.F. Median)
				30,117	269		68,289	837		2,474	34		116,012	33,282 (Close to B.F. Average)
	<b>L</b>	5		18,773	269		38,015	837		Shorter walkway: less pavement	1,229	28	66,720	19,141 (Lower than B.F. Median)
				28,195	269		68,289	837			1,844	28	113,036	32,429 (Close to NDG Median)
	<b>U</b>	6		18,800	269		38,015	837		1,222	26	66,743	19,148 (Lower than B.F. Median)	
				28,201	269		68,289	837		1,833	26	113,071	32,439 (Close to NDG Median)	
<b>5.4m Triplex 2-story</b>	2		18,292	269	Less units in a row	58,183	929	Less units in a row	1,631	35	Less units in a row; Side and back driveways	89,822	25,769 (Close to B.F. Median)	
	4		16,962	269	More units in a row	58,183	924	More units in a row	1,146	28		87,735	25,170 (Close to B.F. Median)	
<b>6.0m Triplex 3-story</b>	3		19,473	269	More units in a row	62,358	891	One more story	1,550	32	Side and back driveways	95,888	27,509 (lower than Assumed Buyer-Low)	
<b>6.0m Triplex 2-story</b>	5		19,727	269		41,531	883		1,307	26		71,950	20,642 (Lower than B.F. Median)	
	6		18,441	269	More units share the land ownership	41,531	883		1,232	28		70,385	20,193 (Lower than B.F. Median)	
<b>7.32m W2u</b>	1		14,164	269		62,141	714		188	8		87,967	25,237 (Close to B.F. Median)	
<b>11.32m W2u</b>	1		29,792	269		86,352	717		774	11		134,456	38,574 (Lower than MTL Average)	
<b>W2u</b>	2, 3, 4, 5, 6		13,692	269	Get one more unit by narrowing the wedth of the unit	59,393	742	Smaller unit, but the cost per square metre is higher than that of a bigger one	166	7	More units share the common space	84,239	24,167 (Close to B.F. Median)	
<b>W3u</b>	2, 3, 4, 5, 6		19,861	269	Get more units by narrowing the wedth of the unit	57,263	729	Smaller unit, but the cost per square metre is higher than that of a bigger one; Share of the common facilities	524	11	More units share the common space	89,295	25,618 (Close to B.F. Median)	

\* : Cost for the inner unit.

\*\* : Cost per square metre for the whole building.

\*\*\* : See "Table : Income, Home Price and Downpayment" at page "AFFORDABILITY".