

A Sensible Route Over Mount Royal: Reducing carbon emissions, traffic delays, and improving safety

Brief submitted by the *Ad Hoc Bicycle Advisory Group*
OCPM Public Consultation, Mount Royal Access Roads
November 2018

**Presented in the interests of all users of the mountain
Focusing on the needs of Bicycle Riders, Pedestrians, the Less Mobile,
and Motorists**

Lane configuration at the site of the collision that led to the death of Clément Ouimet

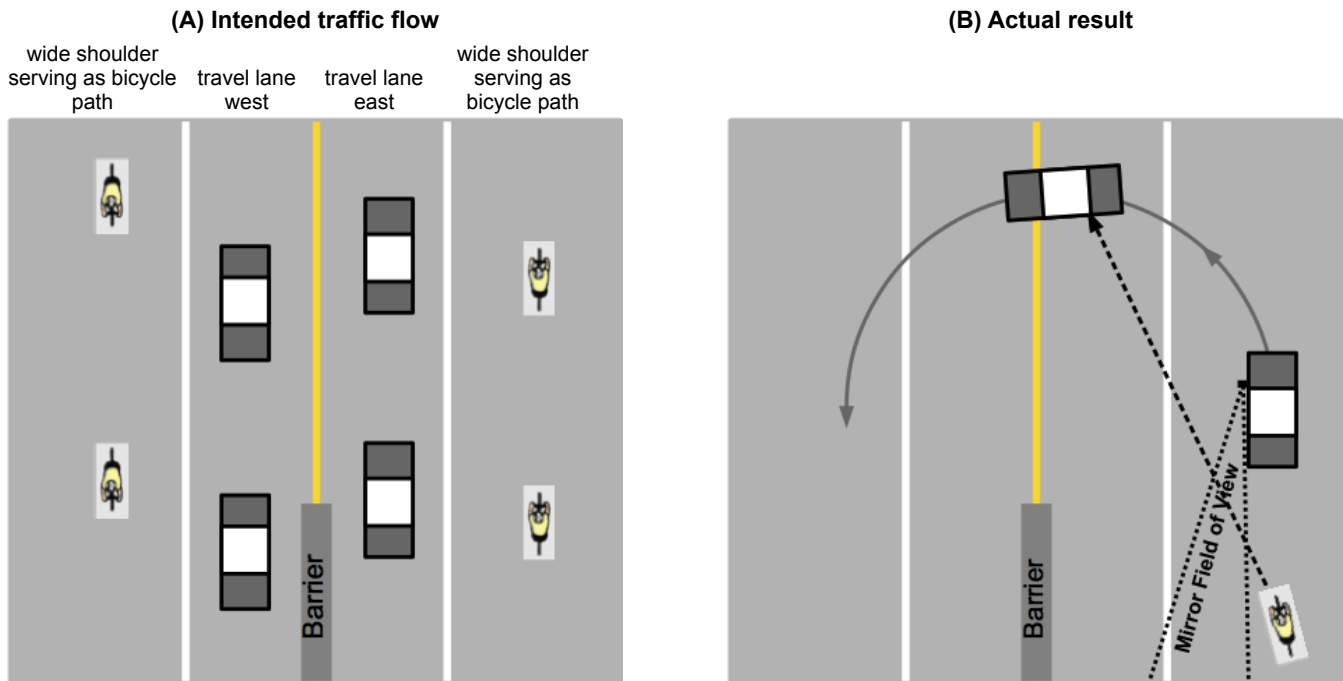

This lane configuration may seem safe... but it isn't.

By ignoring the real needs and behaviours of *both bicyclists and motorists*, the current lane configuration forms the trap that resulted in the death of Clément Ouimet on October 4, 2017. Closure of the road to through traffic and extension of the barrier do not solve the underlying problems.

The problems can be solved, and the overall safety and convenience of all users— bicyclists, pedestrians, and motorists— can be improved, without closing the road to through traffic.

CONTENTS

In Memoriam	1
Summary	2
1. Introduction	3
1.1. Historical background: summary of certain key features of recent previous traffic flow configurations	3
(1) Early period until recent years	3
Fig. 1 Configuration of Camillien Houde parkway in 2006	3
(2) Descent from the crest to Park Avenue, more recently and until shortly after the death of Clément Ouimet	4
(3) Shortly after the death of Clément Ouimet up to the Pilot Project phase	4
(4) Pilot Project phase	4
2. Purposes of the configuration used in the Pilot Project	4
Circumstances of the death of Clément Ouimet	5
3.1. Basic circumstances of the collision	5
3.2. Evaluation of the coroner's report	5
4. Factors that set the stage for the collision	6
4.1. Standard versus abnormal patterns of traffic operation: preventing collisions versus inviting them	6
4.2. Components of the Belvedere – Camillien Houde collision trap	7
(1) Perceived need for U-turns: Absence of a marked route for return	7
(2) Temptation for U-turns: Presence of a wide shoulder	7
(3) Invitation for U-turns: Termination of the concrete median, ineffective signage, stopping prohibition only in reverse direction	7
Fig. 2 Current configuration at the collision site	7
(4) Rapid bicycle travel on the shoulder	8
Fig. 3 Accident site and impact configuration	9
Fig. 4 Mirror visibility distances	9
Table 1 Mirror visibility times	10
Fig. 5 Effect of extension of the barrier on driver sight lines	11
(5) Limitations of bicycle-rider performance	11
Fig. 6 Arc length of travel until arrival at collision point; Highlander acceleration	12
Table 2 Times needed for stopped Toyota Highlander to reach, and then clear the collision point (6.75 m travel, see Fig. 6a)	13
Table 3 Times needed for stopped Toyota Highlander to reach the actual collision position	13
Table 4 Time to full stop for various combinations of braking effort, road slope, and initial speed	14
Table 5 Distance travelled under the braking efforts of Table 4	14
Table 6 Distance travelled for various combinations of times and constant speeds	15
Fig. 7 Sight lines and potential escape routes	16
Table 7 Times to traverse distances marked in Fig. 7	17
(6) Limitations of bicycle helmets	18
5. Analysis of the circumstances of the death of Clément Ouimet	18

6. Two things that should NOT be done in response to the situation	19
7. Proposed remedy	19
7.1. Needs of the various road users	19
7.1.1. Bicycle riders	19
7.1.2. Pedestrians	20
7.1.3. The less mobile: the elderly, handicapped, and the infirm	21
7.1.4. Skiers and skaters	21
7.1.5. Motorists	21
7.2. Features of the proposed remedy	21
7.2.1. Changes at the crest and Belvedere lookout.....	21
(1) Motor vehicle traffic across the crest in one direction at a time only, to allow a two-way pedestrian walkway on one side, and a bicycle lane— westbound only— on the other	
21	
(2) New traffic signals	22
Fig. 8 Locations of new traffic signals.....	23
Fig. 9 Traffic flow during the two basic signal phases	24
Fig. 10 Signals and barrier at Belvedere exit junction during the two basic phases	25
7.2.2. Reconfiguration of the lanes and signage east of the Belvedere parking lot	25
7.2.3. No speed limits for bicycle traffic	26
(1) Speed limits can put riders in a collision trap.....	26
(2) Banked curves require a minimum speed.....	26
(3) Verifying speed requires diverting attention from the road.....	26
(4) Excessive braking on steep descents can cause skidding and a fall	26
(5) Speed limits keep riders who start together, clumped together	26
(6) Young aspiring racers have no other place on the island to hone their skills.....	26
7.2.4. Changes to the concrete median	26
7.2.5. Reconfiguration of sidewalks and bus stop near the Smith House parking lot	27
Fig. 11 Smith House parking area	27
7.2.6. Reconfiguration of the lanes on Remembrance Road from Côte des Neiges heading uphill	27
Fig. 12 Current lane configuration on Remembrance Road, west-bound	27
8. Benefit of the proposed changes: Everybody wins	28
8.1. Bicycle riders	28
8.1.1. The benefits of motor vehicle traffic, and of the new lane configuration on the descent	28
(1) Motor vehicle traffic sweeps the road clear of debris	28
Fig. 13 Sandy debris accumulating in the shoulder	28
(2) Regular motor vehicle traffic is the ONLY way to keep pedestrians from wandering into the path of bicyclists	29
8.1.2. The benefits of the red light	29
8.1.3. The benefits of one-way at a time only vehicle traffic at the crest	30
8.1.4. Elimination of need, temptation, and invitation for U-turns	30
Fig. 14 Maximal no-U-turn signage	30
8.2. Pedestrians.....	30
8.3. Motorists	31

8.4. Environmentalists, lovers of Mount Royal, and the City administration	31
Acknowledgements.....	32
Members	32
Revision history	32
Appendix	33
In Memoriam	A1
1. Introduction: The fundamental fact of life on the public roads	A2
Provision 487 of the Quebec Highway Safety Code: The Far-Right Rule	A2
2.2 Why Provision 487, the Far-Right Rule, is irredeemably unsafe and unfair to both bicyclists and motorists	A2
2.3 Where in the roadway should bicyclists ride, and how will they avoid being hit from behind by overtaking motor vehicles?.....	A4
2.4 If a bicyclist rides in the middle of a travel lane, won't overtaking motorists run them down, either because they won't see them, or because they will?	A5
2.5 A fundamental principle of elementary traffic operation	A6
2.6 Repeal and replacement of Provision 487 of the Highway Code	A6
2.7 How the modified provisions would have prevented the deaths described on page 1 of this document	A8
2.8 A recommendation for the safety and convenience of all users of the public roads.....	A8
3. Equipment provisions of the Code	A10
3.1 Braking.....	A10
3.2 Lighting.....	A11
3.2.1 Comparison of the standards for bicycles and motorcycles	A11
3.2.2 Rational lighting requirements	A11
4. Stop signs.....	A13
5. Signalling	A14
6. Sidewalk riding	A14
7. Miscellaneous bicycling provisions in need of change	A15
7.1 Right to ride in standard manners	A15
7.1.1 Provision 477	A15
7.1.2 Provision 485	A15
7.1.3 Riding side by side.....	A15
8. The needs and rights of pedestrians	A16
8.1 Two fundamental principles of traffic safety.....	A16
8.3 The hazards of pedestrian sidewalks	A16
8.4 Running in the roads	A17
8.5 Walking in the roads.....	A17
8.6 Right to play in residential streets	A18
8.7 Right to behave normally.....	A18
8.8 Pedestrian crossing signals	A18
9. Miscellaneous provisions	A19
9.1 Silent electric vehicles	A19
9.2 Overly bright emergency lights	A19
10. Closing remarks	A19

In Memoriam

Clément Ouimet, aged 18, killed October 4th 2017 while riding his bicycle on the Camillien Houde parkway. His death was the result of a frequent, predictable driver fault, a road configuration that encouraged that fault, and an abnormal pattern of traffic flow— one designed with good intentions, but in ignorance.

*This brief is dedicated to the memory of Clément Ouimet,
and the many other cyclists old and young, male and female,
in Quebec and elsewhere, who were killed because of designed-in,
abnormal, fundamentally unsafe patterns of traffic flow,
created for their safety, but in ignorance—*

***and to those who will be killed in the future,
until those hazardous patterns are recognized,
and eliminated from the roads.***

*Unless otherwise specified, all of the descriptions in this document are based on a direction of travel
from west to east.*

Summary: The lane configuration of the Remembrance Road – Camillien Houde parkway that was in effect on October 4th, 2017, was an accident waiting to happen. On that day, only a few years after this new lane configuration had first been put in place, the foreseeable worst came true: Clément Ouimet was killed while riding his bicycle down the Camillien Houde section. Yet at least three other injury-producing bicycle-motor vehicle collisions had already occurred at the exact same spot in the two years leading up to his death. The City failed to recognize the hazards it had designed into the recent lane configuration. This configuration, though well intentioned to better accommodate bicyclists and to slow motor vehicle traffic, was made without an understanding of the real needs of bicyclists, nor of driver behaviour, nor of the hazards of any abnormal pattern of traffic flow. It made for the collision trap that led to the death of Clément Ouimet.

In response to the death, the City instituted a Pilot Project to block through traffic from one side of Mount Royal to the other, with the inclusion of other associated changes to the lane configurations elsewhere on the route. None of these steps solved the underlying problem, nor any of the other problems of the route, which are detrimental to every one of its users: bicyclists, pedestrians and motorists. Besides failing to solve the old problems, it created new ones. The future configuration envisioned by the City, as illustrated in its Pilot Project documentation,¹ is extraordinarily dangerous, and it is shocking that it might be given any consideration.

This brief proposes a different solution. Its central features are special traffic lights and supporting infrastructure to regulate transit of the crest and access to the Belvedere lookout. These and other features allow, for the first time in the history of the route, a free and clear descent for bicyclists; safe pedestrian access to the Belvedere lookout via the roadway, from either east or west; and motor vehicle entrance to and egress from the lookout from both sides, without any temptation or need for U-turns. The system makes for some delay and therefore discouragement of transit-only motor vehicle use of the route, but without splitting east from west; while it improves access to the park from both sides of the city.

¹ Service des grands parcs, du verdissement et du Mont-Royal de la Ville de Montréal (2018). <http://ocpm.qc.ca/sites/ocpm.qc.ca/files/pdf/P96/3.4_vdemontreal_projet-pilote_ocpm_20180510_vfinale_ang_1.pdf>, p. 46.

*Unless otherwise specified, all of the descriptions in this document are based on a direction of travel
from west to east.*

*Although for clarity and audit trail purposes, various results are presented with precision,
all measurements and calculated values are only approximations,
and should be used only for general guidance*

1. Introduction

1.1. Historical background: summary of certain key features of recent previous traffic flow configurations

(1) Early period until recent years

For much of the history of the paved route from Côte des Neiges to Park Avenue over Mount Royal, over the various segments of the route there were either: two travel lanes in each direction; one relatively wide travel lane in each direction; or, in particular at the pinch point at the crest, one relatively narrow travel lane in each direction. In each case the roadway was bordered by either curbed sidewalks and effectively no shoulders; narrow shoulders of variable width and quality; or, in particular at the pinch point at the crest, effectively no shoulder or sidewalk. *Over essentially no segment was any shoulder wide enough to accommodate a car, and over no segment was any shoulder adequate to safely ride a bicycle downhill.*

Photographs of two key examples of these configurations are shown in Fig. 1.

Fig. 1 Configuration of Camillien Houde parkway in 2006, near the location of the collision involving Clément Ouimet. Photographs taken during the Grand Prix Cycliste Féminin. Configuration remained in place until at least 2010.

(a) Slightly east (downhill) from site of collision involving Clément Ouimet: single wide traffic lane in each direction. Shoulder on left barely adequate to safely ride a bicycle uphill (would not be adequate for downhill). Shoulder on right (location of pedestrians) not of sufficient width or quality for riding downhill. Speed limit sign below the turn indication is for 45 km/hr (not visible behind ascending rider on the right).



(b) Slightly west (uphill) from site of collision involving Clément Ouimet: single wide traffic lane. Shoulder on picture right of variable width and quality, sometimes adequate to safely ride a bicycle uphill. Shoulder in descending direction, not visible behind the barrier, is not of sufficient width or quality to ride downhill.



(2) Descent from the crest to Park Avenue, more recently and until shortly after the death of Clément Ouimet

The inadequacy of the shoulders for bicycle riding caused certain cycling advocates to demand changes. These demands were made under two constraints: the highly dangerous Provision 487 (and earlier similar provisions) of former Quebec Highway Safety Codes, which required bicyclists to keep to the extreme right-hand side of the road (see [Appendix](#)); and the erroneous belief that, when they are available, the safest and best place for bicyclists to ride is on shoulders, thereby keeping the roadway itself free for motor vehicle traffic.

Apparently only after protest from cycling advocates, the City recognized that any barrier-separated bicycle sidepath is catastrophically dangerous for riding a bicycle downhill. Presumably the City has also recognized that speed bumps would likewise be catastrophically dangerous. So instead, with the *intention* of better accommodating bicycle riders, beginning just after the exit from the Belvedere lookout, on the descent to Park Avenue the single wide or double travel lanes with minor shoulders were changed to single travel lanes with wide shoulders. Though there was no signage to indicate that the wide shoulders were to be used for bicycle traffic, this was taken for granted by *most* bicyclists and motorists.

(3) Shortly after the death of Clément Ouimet up to the Pilot Project phase

The concrete median separating the two directions of travel at the first curve below the Belvedere lookout was extended 30 metres. New signage marking the U-turn prohibition was installed near the collision site, the speed limit was reduced from 45 or 50 km/hr to 40 km/hr, and two illuminated speed indicators were installed, one of them near the collision site.

(4) Pilot Project phase

On the ascent from Côte des Neiges, using painted markings the two travel lanes bordered on the right by a curbed sidewalk with no shoulder were made to quickly become a single narrow travel lane with no shoulder. The section from the Beaver Lake parking lot to the Smith House parking lot was made more complicated and traffic in that section was policed. The shoulder of a brief section, beginning shortly after the Smith House parking lot and continuing to a new lookout point before the crest, was further delineated by flexible posts. These posts were marked as a path uniquely for pedestrians to the lookout point, but have confused bicyclists, most of whom expect to use that same shoulder, and who usually find no pedestrian traffic in the space. The descent from the crest to Park Avenue was unchanged.

2. Purposes of the configuration used in the Pilot Project

The elimination of private car through-traffic over Mount Royal and the associated lane reconfigurations have two main purposes.

(1) The first purpose is to uphold a certain vision of urban planning in general, and of Mount Royal park in particular. This vision demands much reduced private car use, and much increased reliance on public transit, walking, and bicycle riding. The reduction in private car use is to be accomplished in three ways: by making private car use less efficient, more costly, and less convenient.

Private car use is to be made less efficient primarily by impeding traffic flow and car access. The configuration of the Pilot Project serves this directly, by eliminating private car

through-traffic. The City's current plan calls for further related impediments to vehicle (motorized and bicycle) traffic flow, such as the demolishing of the overpass at Côte des Neiges and Remembrance Road. Elsewhere in the city, the provision of on-street barrier-separated bicycle paths, and bicycle-specific traffic signal phases, both of which interfere with turning motor vehicle traffic, and which reduce motor vehicle capacity, further contribute to this goal.

Private car use in the city is made more costly and more inconvenient by reducing the total number of public parking spaces and private parking lots; requiring payment for a greater number of public parking spots; and also by impeding traffic flow and car access.

These goals may seem ecologically friendly and bicycle friendly, but there are two important caveats. First, unless and until the distant vision is realized, during the long and indefinite transition phase— when car use is not reduced but instead delays and frustrations mount— **carbon emissions and other pollutants increase**. Second, **safety for bicycle riders is reduced**, precisely because, as just described, bicycle traffic is made to interfere with turning motor vehicle traffic. This aspect is discussed extensively in the [Appendix](#).

(2) The second purpose of the configuration used in the Pilot Project is specifically to respond to the death of Clément Ouimet. His death was in fact the trigger for the Pilot Project, and it is this aspect of the Pilot Project that is the central focus of this brief.

3. Circumstances of the death of Clément Ouimet

3.1. Basic circumstances of the collision

According to the coroner's report,² the fatal collision between Clément Ouimet and a motor vehicle occurred approximately 200 metres below the Belvedere lookout, almost immediately after the first major turn below the lookout, and almost immediately after the end of the concrete median separating the two directions of travel. In other words, the collision occurred at the first opportunity for a U-turn after exit from the Belvedere lookout. The motor vehicle (an SUV driven by an American tourist) was at first stopped on the shoulder. The coroner noted that parking is illegal on the shoulder, but failed to note that near the site the no-stopping sign has an arrow pointing uphill, not downhill. Clément Ouimet was riding downhill at the time, apparently first in the wide shoulder but then moving into the travel lane to avoid the stopped vehicle. At that moment the motor vehicle attempted an illegal U-turn. The collision occurred on the left side of the travel lane, against the passenger-side back door.

3.2. Evaluation of the coroner's report

The coroner's report is adequate only as far as it goes. As has always been the case, the coroner lacked the bicycling-specific knowledge and expertise, and the traffic-engineering knowledge and expertise, that are all required to more fully understand the circumstances and causes of the death.

² Brochu J. Rapport d'investigation du coroner – Loi sur la recherche des causes et des circonstances des décès – concernant le décès de Clément Ouimet – 2017-05321. http://ocpm.qc.ca/sites/ocpm.qc.ca/files/pdf/P96/5.8_2017-05321-01.pdf

For example, the coroner remarked that the rear wheel of Clément Ouimet's bicycle left a skid mark of less than 1 metre in length, implying that Ouimet only attempted emergency braking over that distance. In fact during hard braking effectively all of the stopping power of a bicycle comes from the front brake, and when it is applied hard, the rear wheel is released from the ground, during which time it leaves no skid mark, no matter whether the rear brake is applied or not. On clean, dry pavement, in straight line travel on a normal bicycle, the front wheel cannot be skidded, no matter how hard the front brake is applied. The simple presence or absence of a rear wheel skid mark (in a direction and location left unspecified by the coroner) does not by itself allow any conclusion as to the length of the braking effort, because it leaves open more than one possibility. If the skid mark ran up to the collision site, and was in the direction of the impact, as seem to be implied by the coroner's report, this suggests that there was no effective braking and no speed reduction before the collision.

Nor did the coroner consider the most crucial aspects of the situation: the time it took for the stopped vehicle to get into a position blocking Clément Ouimet's path, the difference between the views of the side and rear-view mirrors, the fields of view of rider and driver, the sight lines of the road, and whether or not the lane configuration itself produced the circumstances of an accident waiting to happen. Consequently, even though the coroner noted that three other recent (2015-2017) injury-producing car-bicycle collisions had already occurred at the same site, the coroner failed to identify any measures that should have been taken immediately to reduce the hazards. The coroner also failed to identify any practical long-term solutions to the ensemble of related problems.

Apparently independent of the coroner, in response to the accident the City extended the concrete median by 30 m. **No one seems to have realized that, for typical driver behaviour, this has essentially no effect on safety, unless the bicyclist rides in the travel lane, not on the shoulder** (Section 4.2, item (4)).

The following section re-analyses the collision circumstances, with a view to remedying these deficiencies of the coroner's report, and of the City's own response to the tragedy.

4. Factors that set the stage for the collision

4.1. Standard versus abnormal patterns of traffic operation: preventing collisions versus inviting them

Standard traffic operation is a system of priorities and behaviours that, while maintaining fair and efficient use of the roads, ensures no two vehicles (motor vehicles or bicycles) are ever in the same place at the same time. In other words, simply yielding the right of way to those who have priority— given circumstances that allow this pattern of yielding (speeds kept so that the sight lines are adequate; vehicle, vehicle operators, and road in working order; etc.)— **ensures that collisions never occur.**

The situation of "an accident waiting to happen" is one where a consistent, conflict-free pattern of priorities and yielding cannot or will not be followed— rarely because of an intent to do damage, sometimes by recklessness; but most often because of some combination of defects

in the design or maintenance of the road, faults in the highway code, vehicle or operator limitations, and normal human psychology.

One such combination of these latter factors is lack of awareness of some danger inherent to a poor road design. For example, the sight lines may be inadequate for the posted speed limits, or conflicting traffic may appear suddenly from abnormal directions. Any such combination forms a **collision trap**.

4.2. Components of the Belvedere – Camillien Houde collision trap

(1) Perceived need for U-turns: Absence of a marked route for return

Once past the area of the Smith House parking lot, a driver coming from the west has no marked or legal way to return to their origin, except by continuing all the way down to the Park Avenue intersection. At that intersection there is still no simple return route.

The absence of signage or visual clue that there will ever be any eventual return path, or if the route is known, the excessive length of it, produce a driver perception of a need to make a U-turn.

(2) Temptation for U-turns: Presence of a wide shoulder

The wide shoulder in the area of the collision site allows drivers to stop out of the travel lane before initiating the turn. The shoulder was not marked as a bicycle lane, but even if it had been, world-wide it is typical driver behaviour to stop in marked bicycle lanes. This typical behaviour can never be relied on to change.

(3) Invitation for U-turns: Termination of the concrete median, ineffective signage, stopping prohibition only in reverse direction

Immediately before the collision site, the concrete median that prevented U-turns terminated. Although U-turns were prohibited, it is not clear from the coroner's report whether the corresponding signage was in place at that location or whether it was sufficiently noticeable, because after the accident new signage was installed to either mark or at least emphasize the prohibition. Despite this the current signage is not sufficiently clear, because the sign with the universal symbol is small and lost in a jumble of other signs, while the larger sign is in French only, with no symbol. It will not normally be understood by American tourists, nor by many others. The signage in the vicinity of the collision site marks the shoulder as a no-parking zone, but the no-stopping sign only has an arrow pointing uphill towards the curve, not downhill in the direction of travel (Fig. 2).

Fig. 2 Current configuration at the collision site. Stopped position of the vehicle that killed Clément Ouimet, just before the attempted U-turn, is in the vicinity of the first signpost. The entirety of the concrete median visible in the photograph is part of the new 30 m extension, which begins shortly before the first signpost. Sign for no stopping has arrow pointing in reverse direction. "No U-turn" signs lost in a distracting jumble of other signs, at least two of which are useless (see Fig. 14).

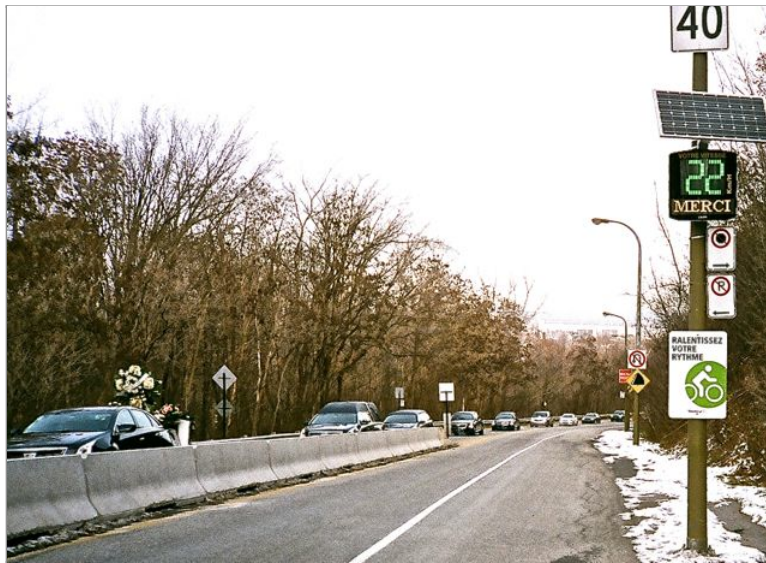

(4) Rapid bicycle travel *on the shoulder*

In the vicinity of the accident site, the lane configuration included wide shoulders and a single travel lane in each direction. Though the shoulder had no signage indicating it was reserved for bicycle travel, it was indeed intended, and typically used for, that purpose. The posted speed limit, now 40 km/hr, at the time was 45 or 50 km/hr, and the latter is easily achieved by competent riders on that section.³

Yet a fundamental part of the system of priorities governing *normal* traffic flow is that ***the roadway is reserved for vehicles that are travelling, while the shoulder is reserved for vehicles that are stopped***⁴— such as during mechanical breakdowns, medical emergencies, or for any other reason. This is why driving on shoulders, especially at rapid pace, is always alarming to other road users, and almost universally prohibited. It is also why enforcement of the prohibition is typically strict.

As a result, when a motor vehicle is stopped on the shoulder for any reason, in the absence of sirens from an emergency vehicle, ***its driver never expects to have traffic overtake from within the shoulder***, let alone to have a high-speed overtaking vehicle suddenly switch from the shoulder to the travel lane just before it passes. Thus in the moments before attempting to turn into the roadway, drivers tend to check backwards only by their side mirror— which gives a view of effectively only the first lane they are going to turn into— not

³ With little or no effort, and without braking, ambient wind, or interference from other traffic, a cyclist descending the Camillien Houde parkway normally reaches a speed of approximately 45 km/hr at the entrance to the curve in question. Standard calculations confirm that under these conditions, by coasting alone (no pedalling), a rider reaches speeds of approximately 40 km/hr after 200 m on a 5% downhill grade, or 52 km/hr on an 8% grade (the maximum grade on the route is 10%, but over a shorter distance, and not over the 200 m before the curve). Upon exiting the curve, a skilled cyclist could achieve speeds of approximately 40 to 50 km/hr or more. **The maximum speed realistically achievable anywhere on the route, with or without pedalling, is at most approximately 55-65 km/hr.** See <https://analyticcycling.com/DiffEqMotionDownhillSprint_Page.html>; for coasting to the curve, use default values, with -0.05 or -0.08 for the slope (5% or 8% downhill), 0 for the starting speed, 200 m for the distance, and maximal and average rider power outputs of 0 watts (nominally, for use with the limitations of this website's particular implementation of the formulas, 0.002 and 0.001 watts). It is not possible to pedal in sharp curves, and it is not realistically possible for pedalling to contribute much if any power at very high speeds. The default values are for riding at sea level, but the minor actual altitude makes effectively no difference to the results.

⁴ Also but much less frequently, for travel by emergency vehicles.

their rear-view mirror, whose view is primarily of the shoulder behind them. Instead of checking the blind spot, the driver may prolong the check of the side mirror, to give time for the blind spot to clear, before finally checking for oncoming traffic just before the U-turn. Even if the driver first checks the rear-view mirror, certainly the last check will not be in the rear-view mirror. This means that even for the most attentive driver, a rear-view mirror check will always be several steps away from the actual movement into the roadway: side mirror check, possibly prolonged or followed by a blind spot check; oncoming traffic check, either before or after or both; and initiation of the movement.

Fig. 3a is a detail from a photograph on page 4 of the coroner’s report. The arrow and circle were placed by the coroner to indicate the location of the collision. Although there is no scale marked on the photograph, using the police drawing in the coroner’s report along with on-site confirmation, it is possible to estimate the distance from the point where Clément Ouimet would have been first visible in the driver’s side mirror, to the point where he would have entered the driver’s blind spot. Because of the topography and vegetation, the stopped vehicle likewise first became visible to Clément Ouimet at approximately the moment he entered the driver’s side mirror field of view. The lengths of straight-line approximations to various curved rider paths within the driver’s side mirror field of view are marked in Fig. 3c.

Fig. 3 Accident site and impact configuration.



(a) Detail from p. 4 of the coroner’s report. Collision site is almost immediately after the end of the concrete median.

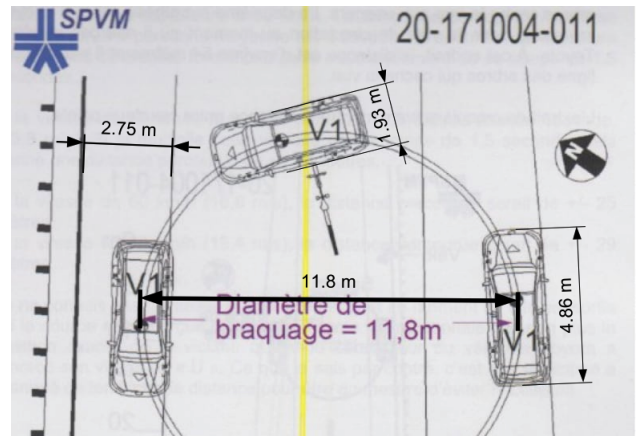

(b) Dimensioned police diagram from the coroner’s report, with consequent additional dimensions marked. An 11.8 m diameter for the turning circle gives the shoulder width marked on the left as 2.75 m. The dimensions of Toyota Highlanders were stable from 2014-2016 at 1.9255 by 4.855 m, almost the same over other years from at least 2005 to 2017, and this is consistent with the diagram.

Fig. 4 Mirror visibility distances. Effect of different rider trajectories on distance rider is visible within driver’s side mirror, and longest length hidden in side mirror forward blind spot. Trajectory through middle of the shoulder: orange, long dashes; trajectory near outside of shoulder: orange, short dashes. Based on the coroner’s report, the path of Clément Ouimet is assumed to be bounded by the two orange trajectories. Approximate path of a rider using the middle of the travel lane instead of the shoulder: green. Approximate angle of view (20°)⁵ from driver’s side mirror: magenta. Dimensions are all straight-line approximations, based on

⁵ <<https://plus.maths.org/content/watch-out-its-behind-you>>

2.75 m shoulder width marked in yellow, derived from police diagram and confirmed by on-site estimation. Location of stopped vehicle based on police diagram; stopped vehicle to scale.

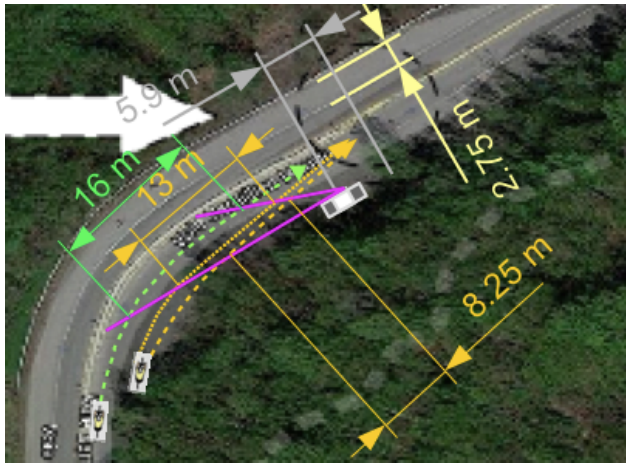

(a) Trajectory through middle of the shoulder: orange, long dashes; trajectory near outside of shoulder: orange, short dashes. Approximate path of a rider using the middle of the travel lane instead of the shoulder: green. Approximate angle of view (20°) from driver's side mirror: magenta. Dimensions are all straight-line approximations, based on 2.75 m shoulder width marked in yellow, derived from police diagram and confirmed by on-site estimation. Location of stopped vehicle based on police diagram; stopped vehicle to scale.

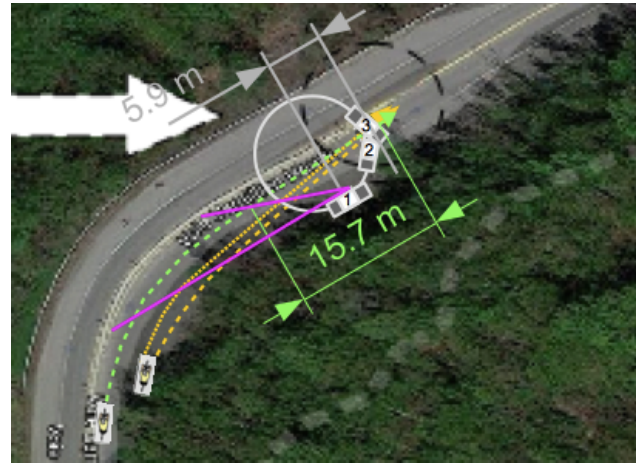

(b) Approximate length of longest path beginning in forward blind spot and ending just beyond any conflict with the turning vehicle (green).

It is evident from Fig. 4a that a rider in the travel lane, instead of on the shoulder, has a substantially improved view of obstacles ahead, is substantially more visible to other traffic, and gives substantially more space and time for both rider and driver to avoid a collision from even a last-moment manoeuvre by a stopped vehicle. A rider using the middle of the travel lane is visible in the driver's side mirror for close to twice the distance of a rider using the middle of the shoulder. The rider likewise has approximately twice the distance to evaluate the situation, does not have to manoeuvre around the stopped vehicle, and has an additional lane's width more of space and time separation, should the stopped vehicle nevertheless suddenly turn into the travel lane.

Based on the distances estimated in Fig. 4a, Table 1 shows that the range of elapsed times over which someone riding in the middle of the shoulder might be visible to the driver, **even if they were riding as slowly as 30 km/hr, is less than 1 second.** For a driver using only their side mirror, **the current 30 m extension of the barrier adds to the driver's sightline ONLY if the bicyclist rides in the travel lane:** see Fig. 5.

Table 1 Mirror visibility times. Ranges of elapsed times (in seconds) that a rider would be visible to the driver, between first appearance in the driver's side mirror and entering the driver's blind spot, based on Fig. 4a. Distance of 8.25 and 13 m, trajectories in the shoulder (orange); distance of 17 m, trajectory in the travel lane (green); all as shown in Fig. 4a.

Additional 30 m of sightline based on the current 30 m extension of the concrete median applies **ONLY to a trajectory in the travel lane**: see Fig. 5.

		Bicyclist Speed (km/hr)					
		30	35	40	45	50	55
Time (seconds) to traverse a distance of:	5 m	0.60	0.5	0.5	0.4	0.4	0.3
	8.25 m	0.99	0.8	0.7	0.7	0.6	0.5
	13 m	1.56	1.3	1.2	1.0	0.9	0.9
	16 m	1.92	1.6	1.4	1.3	1.2	1.0
	(16+30) m	5.52	4.7	4.1	3.7	3.3	3.0

Fig. 5 Effect of extension of the barrier on driver sight lines. Position 1 of the motor vehicle is in the vicinity of the spot where the driver began the U-turn that killed Clément Ouimet. Position 2 is in the vicinity of where a driver might start a similar U-turn (or merge) now that the barrier has been extended. The length of time a rider exiting the curve would be visible in the driver's side mirror has increased essentially **only for riders in the travel lane, not the shoulder**.

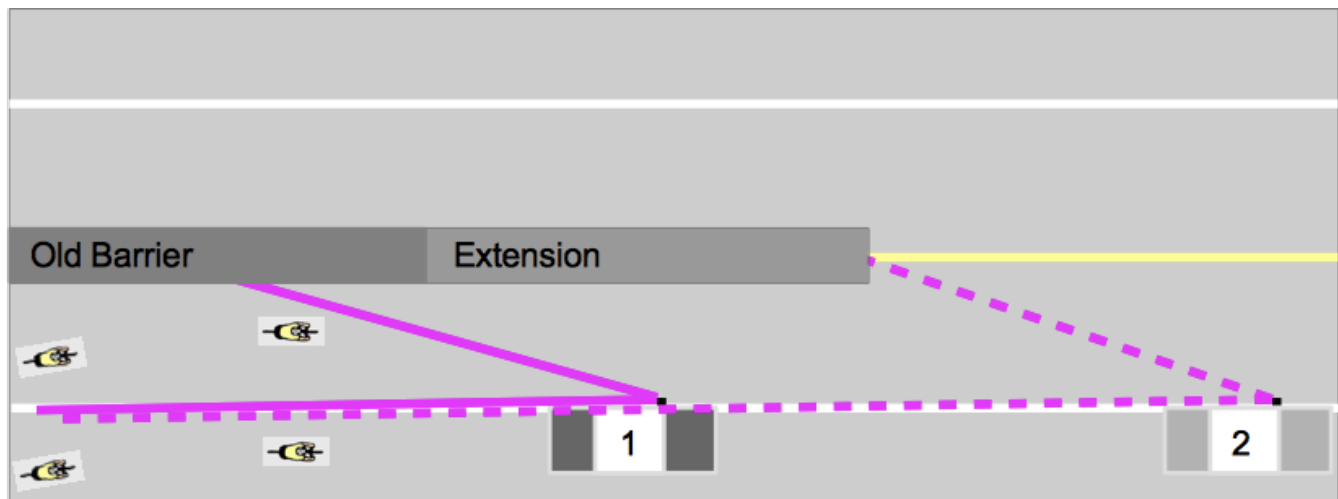

(5) Limitations of bicycle-rider performance

On a bicycle, maximum braking deceleration requires maximum application of the front brake. This acts to take weight off the rear wheel, while the rider's momentum acts to slide the rider forward off the saddle. The result of the sliding tendency, if not countered, is that the thigh strikes the handlebars and the rider is flipped off the bicycle.

In order to avoid being ejected from the bicycle during maximum braking, the rider must be fully braced, with arms in the locked (fully extended) position, and the rider's weight as far back as possible (to the extent of having a thigh or even the stomach, rather than the rider's seat, on the saddle). In other words, on a bicycle, maximum emergency braking requires anticipation and the early adoption of an emergency posture.

On clean dry pavement, with practice on a test track, the maximum braking deceleration that can be achieved by non-professional drivers in a passenger car with ABS brakes is about 0.67-0.87 g ($g = 9.81 \text{ m/s}^2$).⁶ An experimental study found that the 85th percentile of a general bicycle rider sample were able to achieve 0.34 g,⁷ and skilled riders can achieve 0.5 g. A theoretical maximum of 0.66g has been mentioned, and there has been a claim of up to 0.8-0.9 g under ideal conditions,⁸ but these are not achievable in practical situations.

The stopped vehicle was a Toyota Highlander (model year unspecified, 2017 or earlier). Based on the dimensions of the police diagram, the arc length that the Toyota had to travel until it first conflicted with Clément Ouimet's trajectory is approximately 6.75 m (Fig. 6a). U-turns are a relatively slow speed manoeuvre, generally in the range of 20 km/hr or less. At maximum straight-line acceleration from a standing start, a 2018 Toyota Highlander reaches 20 km/hr in 1.635 seconds (Fig. 6b), an acceleration of about 0.35 g.⁹ Table 2 gives the times required for the Toyota to first reach, and then clear the collision point, from a standing start to various final speeds, using this maximum acceleration. For reference, Table 3 gives the times similarly required to reach the actual collision position.

Fig. 6 Arc length of travel until arrival at collision point; Highlander acceleration.

(a) Arc length of travel until stopped vehicle first arrived at the collision point (6.75 m) or the actual collision position (10 m).

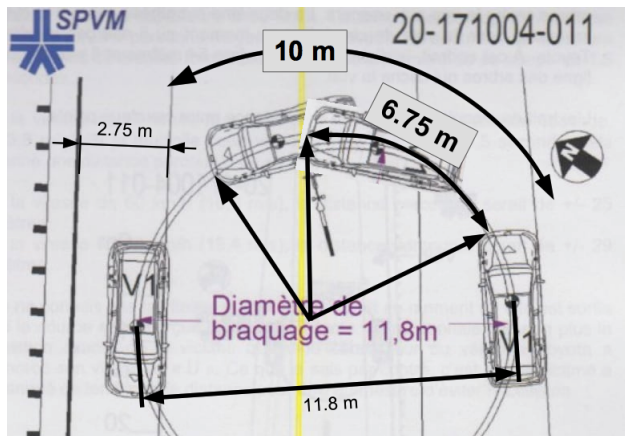

(b) Time for 2018 Toyota Highlander to reach 20 km/hr from a standing start with maximum acceleration: 1.635 s (see footnote 9).



6 Greibe P (2007). Braking distance, friction and behaviour. Table 4.6, p. 42. <<http://www.trafitec.dk/sites/default/files/publications/braking%20distance%20-%20ofriction%20and%20driver%20behaviour.pdf>>

7 Landis B et al. Characteristics of emerging road and trail users and their safety. <<https://trrjournalonline.trb.org/doi/abs/10.3141/1878-16>>

8 For illustrations and discussion of maximal braking on a bicycle, see: Forester J (1993), Effective Cycling, MIT Press, p.205; and <<https://janheine.wordpress.com/2013/08/23/how-to-brake-on-a-bicycle/>>.

9 See <<https://www.youtube.com/watch?v=dFJNkOZTRoY>>. Relative to earlier models, the 2018 has a more powerful engine, and a more efficient 8-speed rather than 6-speed transmission; while the trajectory of the vehicle was a tight turn, not a straight line. As compensation, the slope of the road contributes an additional acceleration, approximately 0.05 g in the downhill direction for a 5% grade. This is approximately 15% of the 2018 Highlander's own maximum acceleration, but it only acts at this amount at the instant the turn is initiated, being gradually reduced as the turning trajectory turns away from the fall line. Because the lower acceleration of the actual vehicle and the increased acceleration of the actual slope act in contrary directions, and individually have relatively little effect on the results, for simplicity they are left out of the calculations used here.

Table 2 Times needed for stopped Toyota Highlander to reach, and then clear the collision point (6.75 m travel, see Fig. 6a), for various final speeds through the U-turn.

	Final (maximum) speed through U-turn (km/hr)				
	10	15	20	25	30
Time to achieve max speed under maximum acceleration (s)	0.82	1.23	1.635	2.04	2.45
Distance travelled (m)	1.14	2.55	4.54	7.10	10.22
Distance remaining to first arrival at collision point (m)	5.61	4.20	2.21		
Additional time needed to reach collision point, at constant speed	2.02	1.01	0.40		
Total time to first arrival at collision point (s)	2.84	2.23	2.03	1.99	1.99
Additional distance to clear collision point (m)	4.86	4.86	4.86	4.51	1.39
Additional time to clear collision point (m)	1.75	1.17	0.87	0.65	0.17
Total time for U-turn to clear collision point (s)	4.59	3.40	2.91	2.64	2.16

Table 3 Times needed for stopped Toyota Highlander to reach the actual collision position (10 m travel, see Fig. 6a).

	Final (maximum) speed through U-turn (km/hr)				
	10	15	20	25	30
Time to achieve max speed (s) under maximum acceleration	0.82	1.23	1.64	2.04	2.45
Distance travelled (m)	1.14	2.55	4.54	7.10	10.22
Distance remaining to collision position (m)	8.86	7.45	5.46	2.90	-0.22
Additional time needed to reach collision position, at constant speed	3.19	1.79	0.98	0.42	-0.03
Total time to arrival at collision position (s)	4.01	3.01	2.62	2.46	2.43

Over the time it takes for these phases of the U-turn, plus the reaction time of the rider, the rider travels a certain distance. This distance depends on the reaction time, the braking effort, the road slope, and the rider's initial velocity.¹⁰ The times required for a rider to stop from various initial speeds under various braking efforts, and the corresponding distances covered, are given in Table 4. The corresponding distances travelled are given in Table 5. During the reaction time, no braking is in effect, and the distances travelled for various constant speeds (to account for reaction time of the rider) are given in Table 6.

¹⁰ Forward wind resistance reduces the distance covered but is not considered separately in these calculations as it can be taken as helping to produce the average braking decelerations listed in the tables. In general, winds may be in the rider's direction of travel or against it.

Table 4 Time to full stop for various combinations of braking effort, road slope, and initial speed. Maximum slope for the whole parkway is 10%, less in the immediate vicinity of the collision site.

Braking effort	Braking deceleration (g)	Slope (%)	Net deceleration (g)	Time to full stop (s)					
				Initial speed (km/hr)					
				30	35	40	45	50	55
Moderate to hard	0.4	5	0.35	2.4	2.8	3.2	3.6	4.0	4.4
Very hard to impractically hard	0.5	5	0.45	1.9	2.2	2.5	2.8	3.1	3.5
	0.65	5	0.60	1.4	1.7	1.9	2.1	2.4	2.6
Likely unachievable even on a test track	0.85	5	0.80	1.1	1.2	1.4	1.6	1.8	1.9
Moderate to hard	0.4	10	0.30	2.8	3.3	3.8	4.2	4.7	5.2
Very hard to impractically hard	0.5	10	0.40	2.1	2.5	2.8	3.2	3.5	3.9
	0.65	10	0.55	1.5	1.8	2.1	2.3	2.6	2.8
Likely unachievable even on a test track	0.85	10	0.75	1.1	1.3	1.5	1.7	1.9	2.1

Table 5 Distance travelled under the braking efforts of Table 4, for various combinations of road slope, initial velocities, and corresponding times to full stop. Maximum slope for the whole parkway is 10%, less in the immediate vicinity of the collision site.

Braking effort	Braking deceleration (g)	Slope (%)	Net deceleration (g)	Distance travelled under braking to full stop (m)					
				Initial speed (km/hr)					
				30	35	40	45	50	55
Moderate to hard	0.4	5	0.35	10.1	13.8	18.0	22.7	28.1	34.0
Very hard to impractically hard	0.5	5	0.45	7.9	10.7	14.0	17.7	21.8	26.4
	0.65	5	0.60	5.9	8.0	10.5	13.3	16.4	19.8
Likely unachievable even on a test track	0.85	5	0.80	4.4	6.0	7.9	10.0	12.3	14.9
Moderate to hard	0.4	10	0.30	11.8	16.0	20.9	26.5	32.7	39.6
Very hard to impractically hard	0.5	10	0.40	8.8	12.0	15.7	19.9	24.5	29.7
	0.65	10	0.55	6.4	8.8	11.4	14.5	17.9	21.6
Likely unachievable even on a test track	0.85	10	0.75	4.7	6.4	8.4	10.6	13.1	15.9

Table 6 Distance travelled for various combinations of times and constant speeds.

		Distance bicycle travels with no braking (m)					
		Constant speed (km/hr)					
Time (s)		30	35	40	45	50	55
Range of reaction times from theoretical minimum to normal	0.1	0.8	1.0	1.1	1.3	1.4	1.5
	0.2	1.7	1.9	2.2	2.5	2.8	3.1
	0.3	2.5	2.9	3.3	3.8	4.2	4.6
	0.4	3.3	3.9	4.4	5.0	5.6	6.1
	0.5	4.2	4.9	5.6	6.3	6.9	7.6
	1.0	8.3	9.7	11.1	12.5	13.9	15.3
Fast arrival of Toyota to first collision point	1.99	18.0	21.0	24.0	27.0	30.0	33.0
Range for Toyota to clear collision zone	2.64	22.0	25.7	29.3	33.0	36.7	40.3
	2.91	24.3	28.3	32.3	36.4	40.4	44.5
	4.59	38.3	44.6	51.0	57.4	63.8	70.1

Together with Fig. 4, these various calculations show that if the rider is in the travel lane, then even for a U-turn begun at the moment the bicycle gets inside the driver's forward blind spot or later, and even for fast U-turn speeds, with brisk riding **the rider clears the collision zone without braking at all**. For slow U-turns the rider clears the zone even at 30 km/hr.

By contrast a rider travelling slowly in the middle of the shoulder (as intended by the road design) is in trouble whether braking or not. Even for the slowest speed of 30 km/hr, with very hard braking (0.5 g) and a normal reaction time of 1 second, the total distance required to come to a full stop is $7.9 + 8.3 = 16.2$ m. Fig. 7a shows that this is substantially longer than the rider's first sight line to the stopped vehicle. **Therefore even at a very slow speed, substantially below the speed limit, a rider travelling in the middle of the shoulder as intended could not have avoided the stopped vehicle by braking.**

The rider could move out into the travel lane to avoid the stopped vehicle, but this lane change might result in a collision with traffic already in the travel lane. If the manoeuvre could be accomplished, Table 7 shows that the rider could end up arriving at the collision zone during the same interval as the turning vehicle (approximately 2 to 4 seconds after initiation of the turn; see Table 2). Only speeds of 40 to 50 km/hr or greater assure that, if vehicle was stopped at the rider's first sight of it, the rider will clear the collision zone no matter when the U-turn is then initiated.

The driver might begin the turn before the rider can see it, so that high speed travel over the trajectories to the left would have the two vehicles arrive simultaneously at the collision zone. But in this case a rider in the shoulder would see the vehicle turning into the lane, and would not change course to head to the collision zone. A rider in the travel lane could move to the right. Even conservatively, not counting the time into the turn already elapsed, in either case the rider would clear the turning vehicle on the right; if necessary, braking would be effective enough to allow time for this (see Fig. 7d; Table 3 and Table 7).

If to avoid the stopped vehicle a rider is moving from the shoulder into the travel lane, and the stopped vehicle then initiates a U-turn, it will be difficult for the rider to make

this out: the angle of the rider's trajectory is away from the vehicle. If the rider does perceive the motion, an escape path to the right would require a second, harder change of direction, likely combined with braking to allow time for the vehicle to clear the path. The rider will traverse the entire short distance in no more than two or three seconds, and it would not be evident which path would be the best one to choose. Taking both reaction and decision times into consideration, any such second change of trajectory is not feasible.

Once the stopped vehicle begins its turn, a rider might risk attempting to move into the lanes of oncoming traffic (a sharp turn at speeds of 30 km/hr and more is not practical, and even if it could be accomplished, it would lead straight into the trees). Presumably these were already clear, to allow the U-turn. It is still a highly dangerous trajectory, as it heads the rider off the road into the trees (Fig. 2). A rider nevertheless somehow able to return to a path on the road will still have that path within the oncoming lanes for an overly long distance. Even if the rider has sufficient time and ability to make the manoeuvre, this is not an escape path as the turning vehicle is also heading into the oncoming lanes. Analysis similar to the preceding (not shown) has the turning vehicle in a collision zone (beginning with the front bumper at the yellow divider line and continuing to the rear bumper past the shoulder stripe) from approximately 2 to 5 seconds after initiation of the turn. This has the same or greater time for trajectories to overlap as a trajectory within the same-direction travel lane (Table 7), and so along with its many disadvantages it does not seem to have any advantage, unless the driver could see the bicycle and brake sufficiently.

Fig. 7 Sight lines and potential escape routes. (a) Sight lines of rider to stopped vehicle for various rider trajectories (assuming the topography and vegetation as shown in the photo block the rider's view earlier). (b) Linear distances from first sight of stopped vehicle to impact location for various rider trajectories. (c) Distances for a dangerous and unlikely alternate escape attempt trajectory. (d) Driver has already initiated the turn before the rider exits the curve (position 1b is turned 14° and advanced slightly from position 1). Sight lines are improved, an escape path to the right opens up, and the distances from first sight to the escape location are improved (curved path length of outside lane trajectory substantially longer than linear distance as marked). Rider travelling at even relatively high speed may have sufficient room to brake to a full stop but does not need to: needs only to slow enough to allow the turning vehicle to clear. Middle of the shoulder: orange, long dashes; outside edge of shoulder: orange, short dashes; middle of travel lane, green.

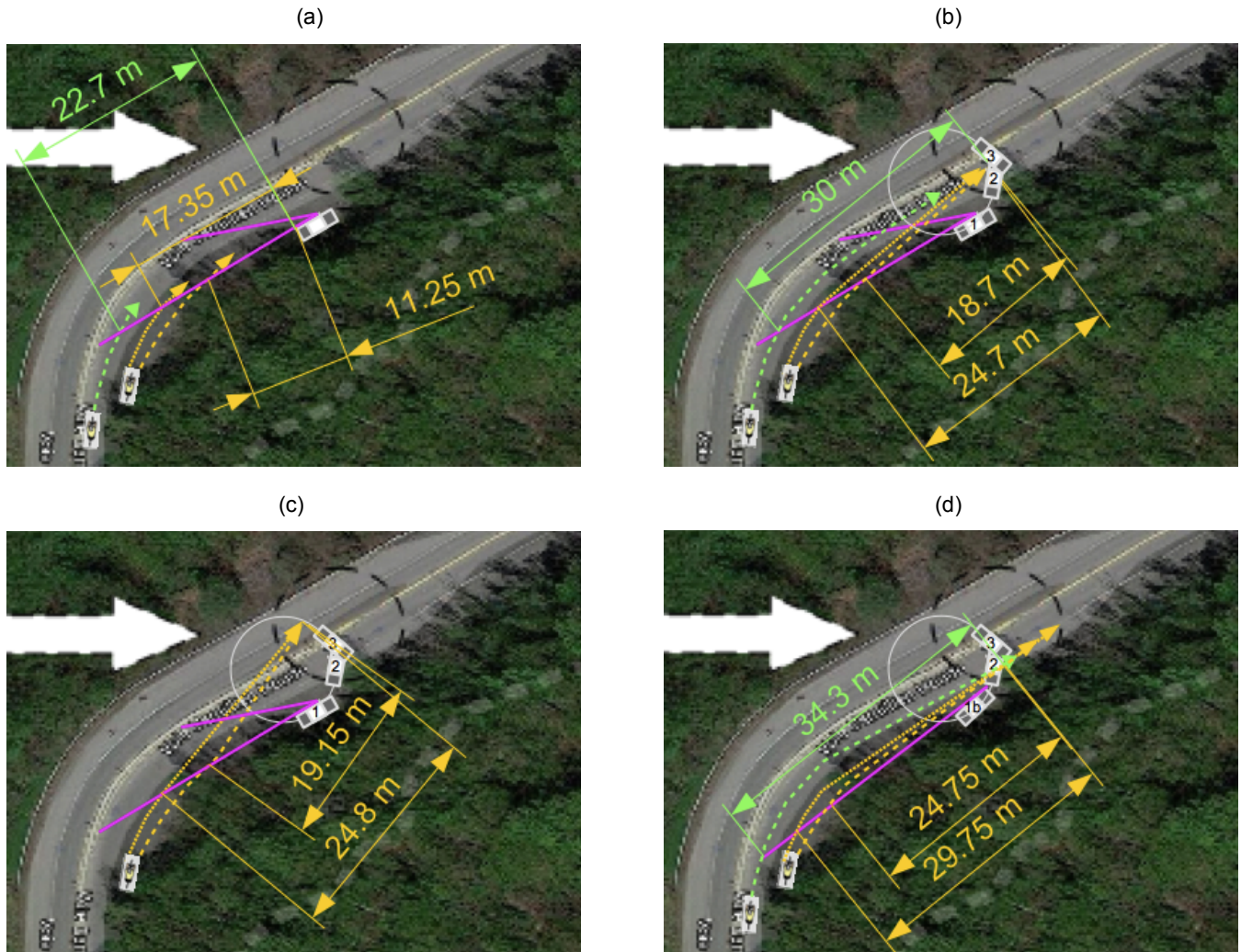

Table 7 Times to traverse distances marked in Fig. 7 at various speeds. Paths from shoulder, orange; paths into oncoming lanes, orange italic; paths from travel lane, green. Green backgrounds correspond to successful escape for either left trajectories (entries left justified) or right trajectories (entries right justified). Red: overlap with simultaneous arrival in collision zone; yellow, borderline. No background: sight line distance. **Table entries in yellow and red for rightward escape paths would turn green with light braking.**

Distance (m)	Time (seconds) to traverse					
	Bicyclist Speed (km/hr)					
	30	35	40	45	50	55
11.25	1.35	1.16	1.01	0.90	0.81	0.74
17.35	2.08	1.78	1.56	1.39	1.25	1.14
18.7	2.24	1.92	1.68	1.50	1.35	1.22
19.15	2.30	1.97	1.72	1.53	1.38	1.25
22.7	2.72	2.33	2.04	1.82	1.63	1.49
24.7	2.96	2.54	2.22	1.98	1.78	1.62
24.75	2.97	2.55	2.23	1.98	1.78	1.62
24.8	2.98	2.55	2.23	1.98	1.79	1.62
29.75	3.57	3.06	2.68	2.38	2.14	1.95
30	3.60	3.09	2.70	2.40	2.16	1.96
34.3	4.12	3.53	3.09	2.74	2.47	2.25

In short: for a rider travelling at speeds of 30 to 35 km/hr, in the shoulder as intended by the road design, there is no escape from the collision trap as it was set for Clément Ouimet. Under those conditions, only speeds of 40 to 50 km/hr or more would allow for escape. If the U-turn is initiated earlier than in Clément Ouimet's case, the higher speeds are still safe with only light braking.

(6) Limitations of bicycle helmets

Standard bicycle helmets (US CPSC standard; Canadian CSA standard is similar) are designed to prevent fatal injury at hard impact speeds of up to between 4.8 m/s (17.3 km/hr or 10.7 mph) and 6.2 m/s (22.3 km/hr or 13.9 mph), depending on the form of the surface that is struck. These impact speeds are achieved by simple vertical falls of 1.2 and 2 m respectively.

The heights of Toyota Highlanders of various years are in the range of 1.73-1.76 m. A rider who escapes head impact with the vehicle, but is ejected over it on a sloped road, is likely to exceed helmet capabilities by the total vertical drop alone. The height of the Highlander alone, without adding the additional height over it due to ejection of the rider, or the additional vertical drop due to the road slope, already substantially exceeds helmet limits for certain impacts and comes close to the design limits for all impacts.

5. Analysis of the circumstances of the death of Clément Ouimet

Descending the Camillien Houde parkway on a path in the shoulder, Clément Ouimet would have been on a collision or near-collision course with a vehicle stopped in the shoulder. The Toyota Highlander must have been stopped, not yet having initiated the turn, because if it had begun to turn into the travel lane, Ouimet would not have also turned into that lane.

It would have taken the Toyota at least approximately 2 seconds to first arrive at the collision point. Even travelling at a relatively slow speed, a rider would cover more than 18 m during this interval, or almost the distance from the position where Ouimet would have first seen the vehicle. If the Toyota had begun to turn much after Ouimet first saw it, then even at low speeds Ouimet would have cleared the collision zone before the Toyota arrived in it. The driver must therefore have started his turn almost immediately after Clément Ouimet first appeared in his driver's side mirror, likewise almost immediately after the Toyota first became visible to Ouimet, approximately 11.25 to 17.35 m in the distance.

As described in Section 3.2, the short skid mark suggests there was no speed reduction before Clément Ouimet arrived at the collision point. From Table 7, this means that Ouimet would have escaped the collision had he been travelling on average faster than the then speed limit of 45 or 50 km/hr. **It demonstrates that, contrary to widespread belief, Ouimet was travelling at below the speed limit, and likely well below it, at no more than 30 or 35 km/hr.** Ouimet had no possibility of escaping the collision by braking. He properly and almost immediately moved into the travel lane to avoid the stopped vehicle, but once the driver began the turn, there was no feasible escape path.

The driver attempted the U-turn because the lack of marked options made a perceived need for it; the wide shoulder made the manoeuvre tempting; and the termination of the concrete barrier and the ineffective, cluttered signage acted as an invitation. The combination of circumstances made for an inescapable collision trap. **The remedies that the City has put in place so far are useless:** the extension of the concrete median does not improve the situation for riders using the shoulder, as intended by the road design; **the**

lowered speed limits may worsen, not better the situation— not only by preventing riders from escaping the trap (Table 7), but also by making U-turns and other dangerous lane changes more feasible; and the signage is now even more cluttered. The Pilot Project's prohibition on through traffic does reduce the occasions for U-turns, but it does not eliminate them; and in any case it does nothing to prevent a similar hazard, namely when a driver only returns to the travel lane from the shoulder, rather than making a U-turn. **The project also increased bus traffic, and bus or any other heavy vehicle traffic is more difficult and dangerous for cyclists than car traffic.**

6. Two things that should NOT be done in response to the situation

Neither of the following should ever be installed anywhere along the route:

- Speed bumps
- Barrier-separated bicycle paths

Both of these are difficult and sometimes impossible to contend with on uphill, and catastrophically dangerous on downhill— especially curving ones such as the Camillien Houde parkway. If the problems are not obvious then the reader has not gone up or down a steep hill on a bicycle, much less ridden the Camillien Houde parkway.

7. Proposed remedy

This section proposes a new configuration and regulation of the route. Its purpose is to both remedy the safety hazards of the current configuration, and respond to the needs of the route's various users.

7.1. Needs of the various road users

7.1.1. Bicycle riders

Besides obvious desiderata such as good condition of the asphalt, at the most elementary level bicycle riders need sufficient room to operate their vehicles. On uphill, there is usually sufficient space for riders to share a wide lane with motor vehicles and still allow for the legally prescribed 1 m clearance¹¹ between the motor vehicle and the outside edge of the handlebars, plus a safe 0.3-0.5 m to the verge (see Appendix). In narrow lanes, such as at the pinch point at the crest, or the uphill from Remembrance Road in the current configuration, safe lane sharing is not possible.

By contrast, on downhill riders need *at least* the full width of the lane to safely operate their vehicles, and it is not safe for riders and motor vehicles to share a lane side by side. On sharp curves where sight lines are reduced, if there are obstacles in the roadway then even at low speeds, braking will not be sufficient to avoid them, and the rider needs the ability to change lanes. Even without obstacles, navigating turns downhill requires skill, and sometimes the desired line cannot be maintained. On downhill curves it is therefore best if there are no motor vehicles in an adjacent lane.

¹¹ For speeds below 50 km/hr. The legally prescribed clearance is 1.5 m at greater speeds.

If the bicycle slips out, the rider's speed does not itself directly contribute to the impact force with a smooth planar roadway, because the velocity is in the direction of the surface. It only contributes if the rider is ejected or flipped, resulting in a gain of height both from the initially ascending path, and the increased vertical drop due to the slope of the road over the distance travelled in the air. This is one reason why it is important for the rider to stay attached to the bicycle, and part of the reason why descents on a BIXI-type bicycle are dangerous. The danger of the high speed instead comes from obstacles the rider might slide into— for example, a concrete lane barrier or edge block. Sliding into a concrete edge block was what killed reigning Olympic road cycling gold medallist Fabio Casartelli during a mountain descent in the July 19th stage of the 1995 Tour de France. Consequently, just as for downhill ski-ing, the placement of unyielding, sharp, or otherwise edged obstacles along the sides of the route such that the rider might slide or otherwise crash into them, should be avoided.

Moving past elementary needs requires an understanding of who the riders are. The key feature of the route over Mount Royal is that it is indeed over a mountain: the steep and long uphill and downhill make it attractive to, and suitable for, only reasonably athletic persons.¹² In particular, the route over the mountain is a vital training ground for Montreal's many club riders and aspiring racers. This is not just for the uphill, but crucially also for the downhill, as it is the only place on the island to practice descending skills, the only one even approximating European racing courses.

These skills must be honed from an early age, when jetting off to train in the Alps is not an option. In practice, this means that if a low speed limit for bicycle riders is enforced, Montreal will never produce a world-class road racer. The parkway is also part of the route for the annual Grand Prix Cycliste Montreal, an important UCI World Tour Event. To keep the event the route must remain challenging, and maintained according to UCI standards.

The challenging nature of the Camillien Houde descent means that all riders need a free and clear path on the descent. Left turns from the ascent into the Belvedere lookout, as currently prohibited, would be particularly dangerous, but so too are the permitted exits from the parking lot. **Importantly, riders also need their path to be free and clear from pedestrians wandering into it.**

7.1.2. Pedestrians

The most important pedestrian need that is currently unfulfilled is a safe and convenient way to traverse the pinch point at the crest. In that vicinity there are only two narrow lanes, with no shoulder, and fencing and steep cliffs on the sides. There is an extremely long detour available, by taking the calèche road to the Cross and the long staircase to the Belvedere lookout, but this is hardly convenient. Pedestrians also need to cross the Camillien Houde parkway to the Belvedere lookout from a bus stop on the ascent, and better sidewalk routing to the bus stop at the Smith House parking lot.

In its documentation relating to the Pilot Project, the City has compared Mount Royal Park to Central Park in New York City, which has successfully closed off private motor vehicle access.

¹² A BIXI station at Beaver Lake or nearby would allow un-athletic persons to ride downhill, but this would be a bad idea. The design of the BIXI that makes it easy to mount and dismount also makes it too easy to get detached from it, including by having the feet slip off the pedals over bumps. It also gives a high centre of gravity and poor handling for the situation. See <<http://injuryprevention.bmj.com/content/21/2/73.full>>.

This comparison misses the most important feature of the mountain, namely that it is a mountain. Pedestrians, especially families using the picnic areas or the activities at either Beaver Lake or Smith house, still need motor vehicle access from both sides of the mountain, and public transport is not sufficient.

7.1.3. The less mobile: the elderly, handicapped, and the infirm

The less mobile, the handicapped and the infirm require motor vehicle access from either side of the mountain to the major points of interest, including Beaver Lake and Smith House. Public transport, even adapted transport for the handicapped, is not sufficient, and taxis of whatever type are too expensive. Nor was the Pilot Project's access plan sufficient: to get to Beaver Lake, those arriving from the east still had to somehow make their way over more than a quarter of a mile from the Smith House lot, and vice versa.

The elderly or handicapped who are more mobile have the same requirements as pedestrians in general, but usually still also require motor vehicle access from both sides of the mountain, with neither public transport nor taxis being sufficient.

7.1.4. Skiers and skaters

Skiers and skaters require motor vehicle access to Beaver Lake from both sides of the mountain. Public transport is not sufficient, nor even practical for large families or groups of skiers.

7.1.5. Motorists

The most important need of motorists that has never been met is convenient access to and exit from the Belvedere lookout in both directions. They need this not just for the views, but also to avoid the need for U-turns. Motorists also need a clear understanding of the behaviour of bicycle riders, and for bicyclists to follow standard patterns of traffic flow. Motorists also need places to be able to pull over to the side of the road and stop, in case of breakdown or emergency.

7.2. Features of the proposed remedy

The proposed remedy answers the needs of each user of the mountain, to the mutual benefit of all users of the mountain. It consists of new traffic signals and associated infrastructure at the crest and Belvedere lookout, a new lane configuration, a new crosswalk, and new signage.

7.2.1. Changes at the crest and Belvedere lookout

(1) Motor vehicle traffic across the crest in one direction at a time only, to allow a two-way pedestrian walkway on one side, and a bicycle lane— westbound only— on the other

In order to accommodate a minimum 1.5-2 m wide pedestrian lane on the Belvedere side, motor vehicle traffic over the crest should be one-way at a time only, with the direction of the flow controlled by new signals and associated infrastructure. To avoid the accumulation of debris in the summer and to simplify snow clearing in the winter, the walkway should not have

a curb. It should instead at first be delineated by paint, and then as time and budgets permit, by different surfacing, such as smooth stones in light grey or red. The surface and edge treatment should allow snow and debris to be cleared in the same pass that the same-side half of the vehicle traffic lane is cleared. The pedestrian lane should lead into and be contiguous with the sidewalk at the Belvedere lookout. On the other side a similarly delineated 1-2 m lane with permanent right of way should be reserved to allow west-bound bicyclists to continue their climb over the crest through all signal phases. This lane should avoid the bus stop and the pedestrian crosswalk (described next), by going around them to the right.

(2) New traffic signals

A traffic signal facing east-bound traffic should be installed near the crest, at the end of the flat section just before the beginning of the downhill (Fig. 8). A matched set of signals facing west-bound traffic should be installed just below the entrance to the Belvedere parking lot, and another set should face the exit from the Belvedere parking lot (Fig. 9).

Pedestrian traverse of the crest within the walkway, or cyclist ascent within the bicycle lane on the other side, should be permitted during all signal phases, either by default or permanent dedicated green signals. On the pedestrian walkway and with its permanent right of way, bicycles may be used in only a very limited manner: at walking speed (approximately 8 km/hr or 5 mph) or less— if pedestrians are present, then for descent only— and so as to leave a minimum of 1 m clearance to any pedestrian. This option is intended mostly for riders of limited ability, who only want to access the lookout, without continuing with the descent.

During the red phase of the crest signal, the Belvedere signal should be green for westbound (uphill) traffic, left turns into the entrance of the parking lot, and left and right turns out of the parking lot exit. The exit may have to be slightly widened to simultaneously accommodate both exit directions. The priority between vehicles turning left from the parking lot exit and other west-bound traffic should be regulated by flashing red signal lights, as shown in Fig. 9c, d. The current median with posts that blocks cross-turning traffic has to be removed.

Only relatively little pedestrian cross-traffic should be expected at the lookout, as it is needed mostly only to get to and from a bus stop on the uphill side. Nevertheless it is important that this cross-traffic be managed, to avoid conflicts with descending traffic, and with traffic turning into or out of the lot.

A conflict-free path without an additional signal phase can be achieved if pedestrians cross in two steps, in a crosswalk at the traffic signal regulating west-bound traffic (at the Belvedere entrance). In between they should shelter in a pedestrian island that replaces the current median and posts. One or the other or both edges of the roadway may need to be modified in the vicinity, to accommodate the extra width of the island. Because pedestrian traffic will be light, while vehicle traffic in each direction at a time will be regular, and the sight line toward the crest encourages caution, in practice pedestrians should obey this system sufficiently for it to work well. **Signage warning of the danger from descending traffic should be added.**

Unless this system is in place, a pedestrian-only signal phase has to be added, with vehicle traffic stopped in all directions (except for right turns at the exit, and west-bound bicycles in the bicycle lane, which goes around the bus stop and the crosswalk). This extra signal phase reduces green time for all users, and for that reason is not ideal. All signal phases for all lights should be as short as reasonably possible, to avoid accumulations of traffic at the stop lines.

The green phase for the crest signal should begin with an advanced green signal phase for bicycles only. The lane configuration should be changed to a single wide vehicle traffic lane between the two-way pedestrian lane and the one-way (westbound) bicycle-specific lane. This vehicle travel lane should be marked for use by both bicycles and motor vehicles, with both bicycle and motor vehicle traffic in one direction at a time only, the direction of travel changing with the signal phase. During the green phase of the crest signal, the Belvedere signal should be red for motor vehicle traffic in all directions, and for pedestrians crossing the east-bound lane. During this phase there should be a cyclist-specific red signal at Belvedere over the general traffic lane, but green over the bicycle-specific lane.

Respect for the red phase of the Belvedere signals over the general traffic lane is so vital to safety that a signal alone is not sufficient. The implementation must include traffic gates of the same type as used at railway level crossings. When activated the gate facing west-bound traffic should block the general vehicle traffic lane but not the bicycle-specific lane, which goes around it to the right.

A similar gate is not necessary at the crest signal, because the route is into a blind curve, and every user benefits greatly from crossing on the green phase rather than the red. The benefits for bicyclists in particular are so great that they may very well deliberately wait out the end of a green phase to start on a fresh one.

The signage at the crest signal should clearly indicate the following:

- (1) Motor vehicles may not pass bicycles on curves
- (2) Motor vehicles may not pass bicycles within the same lane
- (3) No U-turns

All these signs should be clear and easily understandable even to tourists from anywhere in the world. The distracting jumble of other useless signs should be removed (see [Fig. 2](#) and [Fig. 14](#)).

It may be useful to add a sign indicating that it is possible to return via the Belvedere lookout parking lot. An electronic information panel showing whether or not the Belvedere lot is full should be added near the Smith House parking lot.

Fig. 8 Locations of new traffic signals. (a) Location of the proposed crest (west-facing) signal should be approximately at the location of the "Ralentissez votre rythme" sign, and no later than at the second sign. If it is later or much earlier bicycle riders will not obey it, nor will it serve its intended function for motor vehicle traffic. The "Ralentissez votre rythme" sign is distracting clutter that should be removed. (b) Sidewalk to nowhere at the Belvedere lookout. It should be replaced with a smooth, 1.5-2 m wide surface treatment (without curb) that continues over the crest. To allow this, in conjunction with new signals and other infrastructure described in the text, motor vehicle traffic and almost all bicycle traffic over the crest should be one-way only, with the direction of traffic controlled by the signals. The cobblestone surface here and elsewhere at the lookout is too rough: it is bad for walking, accumulates debris in the summer, and snow and ice in the winter. The concrete median should ideally be replaced with a pedestrian island across from the entrance the Belvedere lot, as described in the text. The "Partagez la route" sign is useless, for giving no explanation of how this should be done.

(a)



(b)



Fig. 9 Traffic flow during the two basic signal phases, for a configuration with a pedestrian island half-way across the crosswalk (**if there is no room for a pedestrian island**, instead a third, pedestrian-only signal phase has to be added, with red in all other directions except for right turns at the parking lot exit). (a) Green at the crest for eastbound traffic, red at the Belvedere signals in all directions, except for pedestrians crossing between the bus stop and the pedestrian island, and for cyclists on the bicycle lane. (b) Red at the crest for eastbound traffic, flashing red for left turns from Belvedere exit and for west-bound traffic on Camillien Houde at the same intersection, and green at all the other Belvedere signals, except for pedestrians waiting to cross between the bus stop and the pedestrian island. See also Fig. 10.

(a)



(b)

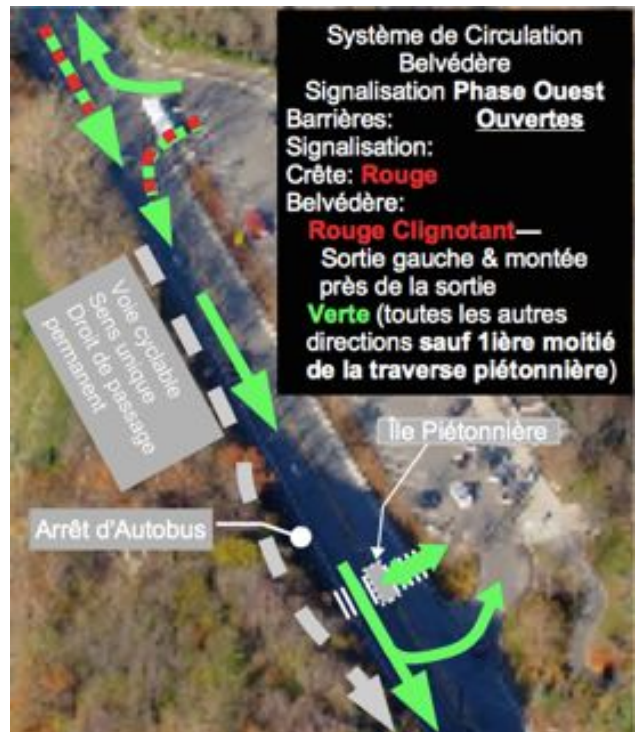
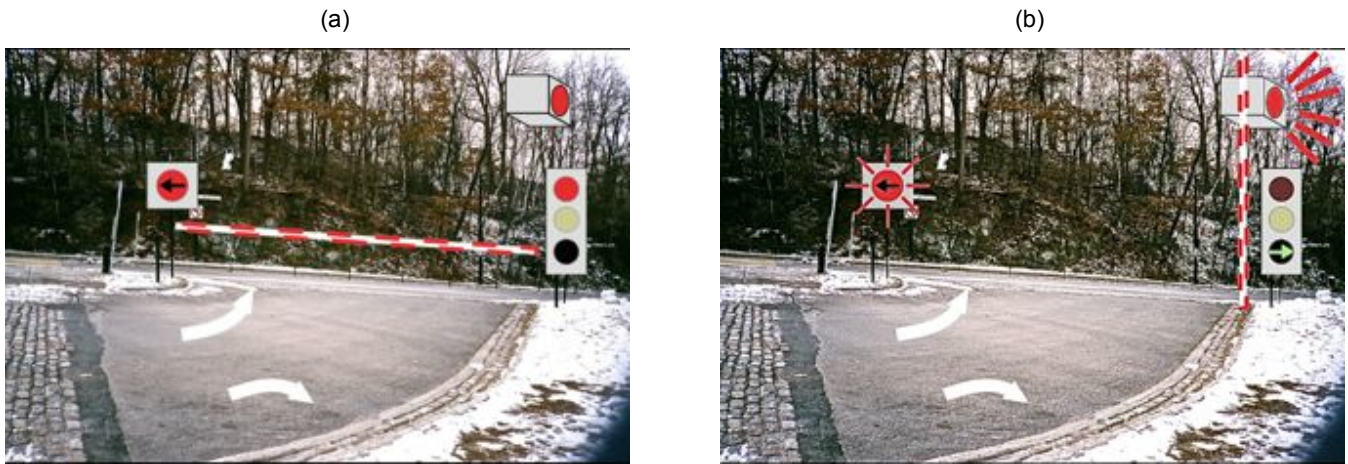

Fig. 10 Signals and barrier at Belvedere exit junction during the two basic phases. (a) Green at crest, exit barrier closed, red in three directions at exit junction. (b) Red at crest, exit barrier open, flashing red for left turns out of the exit, flashing red for west-bound traffic on Camillien Houde at the same junction, and green for right turns out of the exit. See also Fig. 9.



7.2.2. Reconfiguration of the lanes and signage east of the Belvedere parking lot

As explained in detail in Section 4, **on downhills it is vital that there be no bicycle travel on shoulders.** The lanes should be reconfigured to have either a single wide traffic lane with a narrow shoulder, or two traffic lanes with a narrow shoulder, the choice being made according to the available space. The narrow shoulder should be suitable for pedestrian but not bicycle use. It is best that the space be used for a shoulder rather than a sidewalk, because the curb of a sidewalk causes debris to collect. A different surface, similar to what was described in Section 7.2.1, item (1), for the pedestrian lane at the crest, would be ideal. Both traffic lanes should be marked as usable for bicycle travel, and the bicycle markings should be in the centres of the lanes, not their edges. **The signage or lane markings should clearly indicate that on descents, motor vehicles are not allowed to pass bicycles on curves, nor can they pass bicycles within the same lane.** For ascents and descents, signage should indicate a **minimum of 1.5 m passing clearance.**

On the uphill it is possible for motor vehicles to safely pass bicycles within the same lane, if the lane is wide enough. It is also possible for bicycles to be operated with reasonable safety on the shoulder. On uphills most bicyclists will gravitate to shoulders, no matter how narrow, or how poor their conditions. Depending on the available space, there should be either two traffic lanes or one, but in each case with a shoulder of approximately 1.5 m width.

Signage *before* the entrance to the parkway from Park Avenue should clearly indicate that U-turns are not allowed.

7.2.3. No speed limits for bicycle traffic

The speed limits that apply to motor vehicles, whatever they are, should not apply to bicycles. This is for several important reasons:

(1) Speed limits can put riders in a collision trap

This aspect is discussed in Section 4.2, and again in Section 5.

(2) Banked curves require a minimum speed

In order to maintain their line and to keep from being drawn down the fall line— possibly into an adjacent lane, or the gutter— the rider must maintain a certain minimum speed around a banked curve. This minimum speed varies as the curve, the grade and the banking vary.

Unlike with motorized vehicles, it is not possible for a bicycle rider to apply power during a sharp curve, because pedalling while leaned over would lead to a pedal striking the ground. If an obstacle suddenly appears, in order to avoid it and maintain a line around it by ascending the banking, the rider must have entered the curve with speed to spare.

(3) Verifying speed requires diverting attention from the road

Whether using a device attached to the bicycle or checking the roadside indicators, verifying speed requires diverting one's attention from the road. As the circumstances leading to the death of Clément Ouimet should make clear (Section 4.2), descending on a road such as the Camillien Houde parkway requires the rider's full attention.

(4) Excessive braking on steep descents can cause skidding and a fall

Unlike a car, a bicycle is a narrow, balanced vehicle, with narrow points of contact with the road. Any braking on a steep downhill must be done skilfully. It should only be done to suit the local conditions, not an arbitrary speed limit— much less at the last moment before a police speed trap.

(5) Speed limits keep riders who start together, clumped together

A number of riders may arrive at the crest over the length of the red signal phase. Other riders who arrived late in the green cycle may already be waiting there, because of the benefits of starting on a fresh green. If a speed limit for bicycles is enforced, these riders will tend to stay clumped together for the whole descent. Without speed limits, any clumps will almost immediately string out, **to the benefit of everyone: riders, drivers, and pedestrians.**

(6) Young aspiring racers have no other place on the island to hone their skills

As discussed in Section 7.1.1, if speed limits on the Camillien Houde parkway are enforced for bicycle riders, Montreal will never produce a world-class road racer.

7.2.4. Changes to the concrete median

The concrete barriers on the sharp and steep curve serve to protect traffic from collisions with oncoming vehicles that might fail to correctly make the turn. Nevertheless, as discussed in Section 7.1.1, they are a hazard for bicycle riders.

Barriers made of a crushable material could easily be constructed to give the same appearance, but they could not serve the same function, which requires mass or solid

attachment, and strength. **A solution would be to coat the concrete barriers with several inches of crushable material, the most likely suitable candidate being styrofoam, with a slippery surface layer.** In order to keep the barrier at standard width, without the extra inches reducing the already narrow usable width of the roadway, the concrete castings that form the core should be specially made to be that much narrower in width. The weight and strength of the concrete should remain sufficient to maintain their function as barriers, but this should be verified by both calculation and testing.

7.2.5. Reconfiguration of sidewalks and bus stop near the Smith House parking lot
See Fig. 11.

Fig. 11 Smith House parking area. (a) Current sidewalk diverts pedestrians from their destination, the bus stop left of centre in the background. The sidewalk should be made to connect with the bus stop. (b) The bus stop could be moved left to make a bus bay, continuous with the shoulder appearing in the foreground. As is, over the short stretch west of the shoulder, stopped buses routinely produce traffic backups.



7.2.6. Reconfiguration of the lanes on Remembrance Road from Côte des Neiges heading uphill

The current pinching to a single narrow lane should be eliminated, and the complete two-lane striping with no shoulder should be restored. Markings indicating that both cars and bicycles may use the right lane should be placed at lane centre. No matter where the bicyclist rides, whether in lane centre or on the far right, in order to maintain the legally prescribed 1 m passing clearance, cars must pass by encroaching on or changing into the left lane. Signage reminding road users of this legal requirement should be installed.

Fig. 12 Current lane configuration on Remembrance Road, west-bound. The two lanes (a) are needlessly narrowed to one (b), leading to congestion and squeezing out of bicycle riders.

(a)



(b)



8. Benefit of the proposed changes: *Everybody wins*

The Pilot Project blocked motor vehicle through-traffic over Mount Royal. By restoring this traffic, but newly regulating it, *every user of the park wins*:

8.1. Bicycle riders

8.1.1. *The benefits of motor vehicle traffic, and of the new lane configuration on the descent*

Cyclists can benefit from motor vehicle traffic. This in at least two crucial ways:

(1) Motor vehicle traffic sweeps the road clear of debris

On a downhill descent such as the Camillien Houde parkway, sandy debris is extraordinarily dangerous. [Fig. 13](#) shows how, on the most dangerous curve, this debris has hazardously accumulated in the shoulder intended for bicycle travel, because it has no motor vehicle traffic. *Restoring motor vehicle traffic, and eliminating downhill travel on the shoulders, benefits both bicyclists and motorists.* Eliminating bicycle travel from the shoulders— so eliminating the collision trap that killed Clément Ouimet, while leaving a space clear for pedestrians— further *benefits both pedestrians and bicyclists.*

Fig. 13 Sandy debris accumulating in the shoulder. White strip in the centre of the shoulder is sandy debris, not snow. Debris accumulates in the shoulder where motor vehicle traffic is not allowed, because it is swept out of the travel lane by motor vehicles.



(2) *Regular motor vehicle traffic is the ONLY way to keep pedestrians from wandering into the path of bicyclists*

Whenever a roadway accessible to pedestrians is kept free of motor vehicle traffic, pedestrians are sure to wander into it. This is a well-known problem with designated bicycle paths: even when right next to the bicycle path there is a well-marked, equal path for pedestrians, pedestrians will still walk, stop, or wander aimlessly in the bicycle path. This unavoidable behaviour is dangerous enough in flat areas, but on a downhill such as the Camillien Houde parkway, it is catastrophically dangerous.

The future of the parkway envisioned by the City, as presented in its Pilot Project documentation,¹³ is illustrated with a concept rendering having a configuration that invites pedestrian traffic into the roadway. There is already one pedestrian in the roadway, the woman walking her bicycle. The steep slope of the road is somehow levelled: rather than what it is, a mountain descent, it looks like any other bicycle path in a flat park. The roadway is so narrow that a rider overtaking a stopped bus (whether stopped for passengers, or immobilized for any other reason) cannot even move into an adjacent position, the only opening available being the oncoming dense mix of traffic— **a collision trap even worse than the one that killed Clement Ouimet**, for it has no escape possibility for any trajectory or speed. **This future configuration is misleading and catastrophically dangerous, and it must not be implemented.**

By instead restoring motor vehicle through traffic, both pedestrians and cyclists are protected from hazardous mixing on a steep downhill.

8.1.2. The benefits of the red light

Cyclists are notorious for disobeying stop signs and even red lights. Why should they obey the red light proposed here? *Because doing so gives them enormous benefits.*

By beginning their descent at the start of the green signal phase at the crest, cyclists are assured of a free and clear descent all the way to Park Avenue. Unlike today or in the past, they will never face traffic entering or exiting from the Belvedere parking lot. Bicyclists often descend various parts of the parkway faster than motor vehicles, especially on the sharp turns, but now they will never have to overtake them, and motor vehicles are no

¹³ Service des grands parcs, du verdissement et du Mont-Royal de la Ville de Montréal (2018). http://ocpm.qc.ca/sites/ocpm.qc.ca/files/pdf/P96/3.4_vdemontreal_projet-pilote_ocpm_20180510_vfinale_ang_1.pdf, p. 46.

longer allowed to pass riders except when safe. Combined with the new traffic signals, **this separates bicycle and motor vehicle traffic in a way that is beneficial to both, without the hazards of a separate bicycle lane.**

8.1.3. The benefits of one-way at a time only vehicle traffic at the crest

Besides being the feature that allows all the other benefits, one-way traffic is beneficial to bicyclists in another way. The blind curve through the crest is narrow enough that if a rider is overtaken by a vehicle at the same time as another vehicle arrives in the other direction, and one or both of those vehicles is a wide vehicle, there may very well not be enough room for all three— or all four, if there is simultaneously a rider in the other direction. The result will be that it is one or both riders who get crushed, rather than the drivers allowing their vehicles to collide head-on.

8.1.4. Elimination of need, temptation, and invitation for U-turns

With the current configuration, the need for U-turns, the tempting wide shoulder, and the configuration that acts in effect as an invitation for them, combine so powerfully that even signage such as depicted in Fig. 14 would not be enough to eliminate them. The configuration proposed here eliminates U-turns by instead making them unneeded, by taking away the ideal setting for them, and lastly by finally making the signage clear to anyone.

Fig. 14 Maximal no-U-turn signage. Likely would never be installed due to aesthetic considerations. With or without the overhead sign, the "Ralentissez votre rythme" sign and the rockslide sign are distracting, useless clutter that should be removed.



8.2. Pedestrians

All motorists are pedestrians too. Allowing motor vehicle through-traffic and access to all features of the mountain from both sides allows them to benefit from the park as pedestrians as well as motorists. It improves access for the elderly, families, the handicapped, and the infirm. The new regulation of traffic over the crest finally allows pedestrians safe and direct

access to the Belvedere lookout from either direction. Bicycle riders are kept from buzzing them on descents, the shoulders being left free for pedestrians.

8.3. Motorists

Motorists regain the ability to cross the mountain, and access from either side. They gain full use of the road width. On the descent to Park Avenue they are separated instead by time from almost all bicycle traffic, while on the ascents they have the room to manoeuvre around them.

8.4. Environmentalists, lovers of Mount Royal, and the City administration

The new configuration and traffic signals at the crest and lookout make for some delay, and thus discouragement, of transit traffic over the mountain. Yet this is done without cutting one side of the city off from the other, and without the popular outrage. The mountain is made more accessible to everyone, including pedestrians, families, the elderly, the handicapped, and the infirm. The availability of the alternate route, and the resulting improved flow, make for reduced carbon emissions and pollution from the same traffic volume. Yet the vastly improved safety and accommodation for bicyclists, and the vastly improved interaction between motorists, bicyclists, and pedestrians, encourages people to traverse and access the mountain without cars, and makes life easier for everyone: finally a result where

– Everybody wins –

Acknowledgements

The author thanks JS Allen for permission to use the bicycle rider graphic, and JS Allen, J Schubert, J Kary and E Elbourne for helpful comments.

Members

The members of the *Ad Hoc Bicycle Advisory Group* are:

M Kary, PhD

J Kary, BCL LLB

JS Allen, B Eng

<http://bikexpert.com/streetsmarts/index.htm>

<http://john-s-allen.com/>

<https://www.sheldonbrown.com/index.html>

J Schubert, BA

<https://cyclingsavvy.org/tag/john-schubert/>

<https://www.lvcat.org/lvcat/author/schubs/>

Revision history

November 22 – December 3 2018:

-Minor typos corrected, minor improvements to wording.

-Caption to [Table 1](#) and paragraph preceding it changed to refer to situation in general.

-Section [4.2 \(4\)](#) and caption to [Fig. 7](#) changed to explain that the reason the stopped vehicle first becomes visible to the rider at the same position as the rider first appears in the driver's side mirror is that the topography and vegetation are assumed to have blocked any earlier view by the rider.

-Direct measurement of arc length to collision position added to [Fig. 6a](#) (rounded to 10 m, instead of previous 9.99 m estimate); [Table 3](#) changed accordingly.

-[Table 6](#), range of estimated times for Toyota to clear collision zone changed to start at 2.64 instead of 2.62 seconds.

-Footnote [3](#) (Section [3](#)) changed to refer to situation in general, and to use more realistic values of the slope in the vicinity of the curve in question (5 and 8% rather than 5 and 10%). Comments added concerning possible contributions of pedalling. Values for maximum speed realistically achievable anywhere along the route added.

-In last sentence of 2nd paragraph of Section [5](#), changed "...the Toyota first became visible to Ouimet, approximately 18.7 to 24.3 m in the distance" to "...the Toyota first became visible to Ouimet, approximately 11.25 to 17.35 m in the distance". 18.7 and 24.3 m are the corresponding distances to the collision point, not the stopped vehicle.

-Sections [7.2.1 \(1\)](#) and [\(2\)](#) modified to so as to include a 1-2 m wide bicycle lane for west-bound (ascending) riders only, with permanent right of way, to allow riders to continue their ascent whatever the signal phase. Description of bicycle use of the pedestrian walkway clarified.

-Section [7.2.3 \(2\)](#) expanded to cover issues arising from possible need to avoid obstacles that might be encountered on a sharp banked curve.

-Membership roster added.

-Revision history added and table of contents updated accordingly.

December 4 2018 – December 6 2018:

-Section [7.2](#) modified to change location of pedestrian crosswalk from Belvedere exit to Belvedere entrance, and so to simplify the signal phases. Includes addition of new [Fig. 9](#) and [Fig. 10](#). Recommendation to add near the Smith House parking lot an electronic information panel showing whether or not the Belvedere parking lot is full.

-Section [7.2.2](#) clarified: prohibition on passing on curves or in the same lane applies to descents only. For ascents and descents, signage specifying a minimum of **1.5 m** passing clearance should be installed.

-Section [7.2.6](#): [Fig. 12](#) added showing current lane configuration of Remembrance Road, west-bound.

Appendix

Brief submitted as part of the SAAQ's
public consultation for the new Highway Code, March 3 2017

Making Quebec's Highway Safety Code Make Sense: Normalizing traffic flow, equipment, responsibilities, and rights

A brief submitted as part of the SAAQ's public consultation process— March 3 2017
(revised and expanded June 7 2017, minor revisions November 9 2018)

**Presented in the interests of all users of the public roadways
Focusing on the needs of Bicycle Riders, Runners, Walkers, and Motorists**

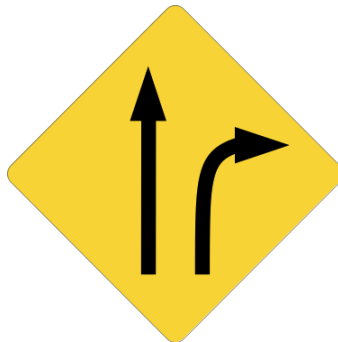

This traffic sign makes sense

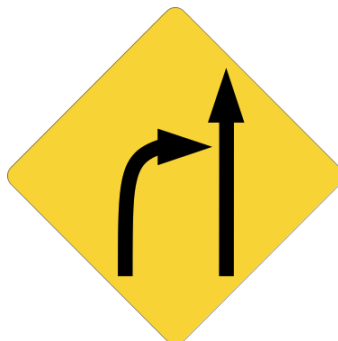

This traffic sign does not make sense

Is the next one somehow any better?



(Depiction of a species of traffic sign common in Montreal, and of a traffic flow
mandated by Provision 487 of the current Quebec Highway Safety Code)

In Memoriam

Suzanne Squire, aged 55, killed July 25th 2013 while riding her bicycle in Montreal, because she obeyed Provision 487 of the Quebec Highway Safety Code.

Mathilde Blais, aged 33, killed April 28th 2014 while riding her bicycle in Montreal, because she obeyed Provision 487 of the Quebec Highway Safety Code.

Justine Charland St-Amour, aged 24, killed August 22nd 2016 while riding her bicycle in Montreal, because she obeyed Provision 487 of the Quebec Highway Safety Code.

Nusrat Jahan, aged 23, killed September 1st 2016 while riding her bicycle in an Ottawa bicycle lane, because the lane followed Section 147 of the Ontario Highway Traffic Act.

This brief is dedicated to the memory of these women, and the many other cyclists old and young, male and female, in Quebec and elsewhere, who were killed because they obeyed discriminatory, ignorantly-written laws that treated them as second-class human beings on the public roadways, just because they used a bicycle as their vehicle of choice—

and to those who will be killed in the future, until those laws are repealed.

1. Introduction: The fundamental fact of life on the public roads

Whether you drive a Ferrari or calèche, ride a bicycle or walk, you will cause delays to other road users, and be delayed by them.

The fastest vehicles on the road are the Ferraris and Lamborghinis. The slowest are not bicycles, rather the horse-drawn vehicles. But even Ferraris and Lamborghinis have to stop and back up to park between cars, and have to merge into traffic from their parking spots. Consequently, when there is traffic, at least once or twice in every trip, and often many more times each trip, drivers of even Ferraris and Lamborghinis will delay other road users—including those in calèches or riding bicycles.

In short, while bicyclists and pedestrians sometimes delay motorists, it is often the case that motorists delay bicyclists and pedestrians. ***The question is not how to eliminate delays, but how to manage them, so that they are brief, safe, and fair.***

2. Provision 487 of the Quebec Highway Safety Code: The Far-Right Rule

2.1 First- and second-class human beings

The Highway Safety Code works like a food chain, with pedestrians at the bottom, followed by cyclists, then cars.

— Montreal police Highway Safety Officer André Durocher, July 22, 2015
(<http://montrealgazette.com/news/local-news/montreal-police-remind-cyclists-to-follow-the-safety-code>)

This statement by a Montreal police officer perfectly encapsulates the attitude responsible for Provision 487 of the Quebec Highway Safety Code, which reads as follows:

487. Every person on a bicycle must ride on the extreme right-hand side of the roadway in the same direction as traffic, except when about to make a left turn, when travel against the traffic is authorized or in cases of necessity.

The purpose underlying this provision is neither the safety nor convenience of bicyclists. It is to codify the principle that those who ride bicycles are, and are to be treated in law as, inferior to those who drive cars; and consequently, that bicyclists must at all costs be kept out of the way of motorists. Yet by putting the bicyclist in a position that runs counter to elementary traffic operation (see the illustrations on the cover page of this brief), *for the sake of eliminating what would otherwise be brief, manageable, safe and fair delays between junctions, **Provision 487 forces motorists into unmanageable, unsafe, unfair, and often interminable delays at junctions, and when exiting their vehicles.***

2.2 Why Provision 487, the Far-Right Rule, is irredeemably unsafe and unfair to both bicyclists and motorists

Provision 487 puts bicyclists straight in the path of multiple, unmanageable dangers, and causes unmanageable delays for motorists.

The delays for motorists start at right turns, with those caused by having to search for

possibly high speed traffic either in their right blind spot, or approaching from their right rear. These delays are bad enough, because it is difficult for drivers to discern bicyclists in their right side mirror, and once the right blind spot and rear approach have been thoroughly checked, the driver must check again for pedestrians, as well as other motor vehicles potentially turning left from an oncoming lane— after which the motorist will have to check again for bicyclists on the right or approaching from the rear— thus trapping the motorist in a potentially never-ending cycle.

The delays for motorists caused by Provision 487 of the Code continue when they attempt to exit their vehicle. ***Provision 487 obliges bicyclists to ride adjacent to cars parked on the right***, thus putting riders in permanent danger of being hit by motorists opening doors to exit their vehicles. Motorists wishing to exit safely must wait for an opening in a sometimes lengthy stream of continuous bicycle traffic. ***In these circumstances mistakes are inevitable and unmanageable.***

Finally, motorists too often experience the final delay caused by Provision 487: because 100% vigilance is impossible, and because Provision 487 puts bicyclists and motorists in frequent, unmanageable conflict, eventually and inevitably a motorist will strike a bicyclist who obeys it. Unless they want to turn a collision into a hit and run, the motorist will then lose many hours, and likely much more, as the consequences run their course.

While motorists are frequently delayed because of Provision 487— a situation opposite to its intent— as noted on page 1 of this document and as reiterated just previously, bicyclists are too often killed or seriously injured by it. This for the following reasons:

- (1) The extreme right-hand side of the roadway is generally in poor condition, broken up or strewn with debris. Bicyclists (and bicycle tires) are sensitive to poor road conditions, and these often cause falls.
- (2) Bicyclists need manoeuvring room to safely operate their vehicles. If a wheel contacts the curb or other obstacle, it will often lead to a fall.
- (3) Pedestrians often step off the sidewalk into the roadway without looking, either accidentally or deliberately, or they may swing their arms or their baggage or drop objects into the path of a bicyclist riding at the extreme edge of the roadway.

For these reasons alone, in general a bicyclist riding on city streets should never maintain a path within about 0.5 metres of a curb, and greater clearance is highly desirable. **The extreme edge of the roadway is the gutter, and the gutter is not a suitable place for riding a bicycle.**

- (4) If the bicyclist is riding adjacent to parked cars, unless riding very cautiously **and** at no greater than walking speed, it is impossible to safely avoid a suddenly opened car door.

Suzanne Squire, whose death was noted on page 1 of this document, successfully avoided a car door that opened suddenly in her path, but in so doing she went into the path of an overtaking bus and was killed. Exhorting drivers to be always on the alert, to always look for fast-approaching bicyclists before opening their doors, and imposing large fines when they do not—

will not prevent these fatal mistakes from recurring, over and over again. Only riding outside the danger zone solves the problem.

For this reason alone, no bicyclist should ever maintain a path within approximately 1.25 metres (4 feet) of a line of parked cars, unless they are riding very cautiously and at no more than walking speed. **This is for the safety and convenience of motorists as well as bicyclists.**

Because passengers and even drivers sometimes disembark from cars stopped in traffic, bicyclists should similarly not ride within 1.25 metres of either the passenger or driver sides of cars stopped in traffic, unless they are riding very cautiously and at no more than walking speed.

(5) As illustrated on the cover page, and as previously described for motorists making right turns, **it puts bicyclists into fundamentally unsafe and unmanageable conflicts at every intersection.**

2.3 Where in the roadway should bicyclists ride, and how will they avoid being hit from behind by overtaking motor vehicles?

The following principles describe the elementary patterns of traffic flow, and as such are essentially the standard content of many highly respected bicycling instruction programmes, such as CyclingSavvy, CanBike, Effective Cycling and Bicycling Street Smarts. Further information is available at e.g.:

<http://bikexpert.com/streetsmarts/usa/index.htm> (available in French at: <http://john-s-allen.com/bssfrench/>)
https://www.lmb.org/index.php?option=com_content&view=article&id=951:rules-of-movement-with-cyclingsavvy&catid=159&Itemid=304
<http://iamtraffic.org/education/cyclingsavvy-works/>

The reader is strongly encouraged to extensively consult these and many other related online resources.

Bicyclists should choose their position on the roadway— and motorists should expect to see bicyclists on the roadway— according to the normal rules of efficient and safe traffic operation. In this context (in right-hand drive jurisdictions), this means:

(1) Slower traffic keeps to the right hand *lane*.

In addition, sometimes a lane is wide enough that, if bicycle riders keep to the right hand *side* of the lane, the lane can be safely shared by both bicycle and motor vehicle traffic. How wide is wide enough depends on the width and speed of the adjacent vehicles, the width and speed of the bicycle and rider, and the road conditions. Even under good conditions, at normal speeds no lane less than about 3.65 metres (12 feet) wide can be safely shared with compact-sized passenger cars. In lanes substantially narrower than this and sometimes even in lanes of this width or wider, motor vehicle traffic will already have to encroach into the adjacent lane in order to obey the minimum passing clearance provisions of the Code (Provision 341).

Therefore, in these situations, it causes the motorist no extra delay to change lanes completely. In order that the motorist not be misled into thinking it is safe to pass within the same lane, in these situations the bicyclist should, and should be expected to, ride in or near the centre of the narrow lane.

If there is no adjacent lane that can be used for passing, in order to avoid unnecessarily delaying overtaking traffic, the bicyclist should and should be expected to ride in or near the centre of the lane for only a limited time. This should be until a suitable and safe opportunity presents itself to either pull over and let traffic go by safely within the lane; or until the lane widens or an adjacent lane becomes available for safe passing.

The situations where there is no available adjacent lane that can be used for passing are generally those of low traffic and any resulting delays are correspondingly minimal.

(2) Pass on the left.

Bicycles often travel more slowly than motor vehicles, but not always. When a bicycle is maintaining a speed sufficient to safely overtake a motor vehicle, the bicyclist should pass on the left, and then merge back into the right-hand lane once the pass is completed. Bicyclists should not pass on the right in the same lane as other traffic, unless there is no possibility for a right turn and unless they are riding very cautiously, typically at no more than walking speed. Bicycles should never pass heavy vehicles, and above all buses, on the right. (Streetcars cannot suddenly turn, and they typically run in the left-most lane in the direction of travel, so both bicycles and motor vehicles have to pass them on the right, when the way is clear.)

(3) Use the lane that corresponds to the destination ("destination positioning").

Bicyclists should not ride straight through in right turn only lanes (unless while at their left-hand edge), and especially not on the right side of them. They should use the adjacent straight through lane. They should use the right turn lane for turning right, and they should do so from the centre of that lane. They should use the left turn lane for left turns— if there is no left turn lane, they should stay on the left or centre of the left-most travel lane of their direction.

(4) When approaching a junction or when waiting in a line of traffic at a stop and intending to ride straight through the junction, a bicycle rider should move to the centre or left of their travel lane, to ensure they remain visible to cross and overtaking or oncoming potentially turning traffic, to stay out of the way of same-direction right-turning traffic, and to ensure they have manoeuvring room in case of driver inattention.

2.4 If a bicyclist rides in the middle of a travel lane, won't overtaking motorists run them down, either because they won't see them, or because they will?

The experience of countless safe bicyclists around the world over the entire span of time that bicyclists and motorists have co-existed is that no, they will not. The major frustration of motorists is that bicyclists ride unpredictably and come from out of nowhere, not that the motorist may have to change lanes to pass them. Both those anxiety-inducing faults are inevitable outcomes of Provision 487: bicyclists on the far right will frequently end up suddenly swerving to avoid the many obstacles in their path, and they will come at vehicles from the right rear blind spots— or from the left rear blind spots, for vehicles parked on the right. Riding in the centre of narrow lanes keeps bicyclists out of the way of road-edge hazards and out of driver blind spots, keeps them directly visible to overtaking traffic, and stops the interminable and unmanageable delays at intersections caused by far-right riding.

Bicyclists who unsafely stay out of the way of motorists by keeping to the far right in between junctions will automatically get in the way of motorists at junctions, precisely where

most collisions occur. *Keeping to the normal traffic flow, by not being on the turning side of turning traffic, benefits both bicyclists and motorists.*

2.5 A fundamental principle of elementary traffic operation:

The overtaking driver or rider is always responsible for rear-end collisions, unless the forward vehicle suddenly swerved into the lane.

This is a fundamental principle of *almost* all jurisdictions: drivers must maintain the spacing and control of their vehicle such that they avoid hitting any obstacle that appears in front of them. For night driving, this is embodied in the standard rule to "avoid over-driving your headlights". Correspondingly, roadways must be built and speed limits set so that the sight lines are sufficient to allow this safe behaviour.

The word *almost* applies here because a recent Quebec Superior Court decision violated this principle. In a notorious case, a woman stopped her car in the left-hand lane of a highway with a posted 90 km/hr speed limit, in order to rescue ducks in the road. She may not have activated her emergency lights. A motorcycle travelling in that lane— at between 113 and 129 km/hr, or between 26 and 43% over the speed limit— failed to stop in time, killing its two occupants in the resulting collision. A second motorcycle, travelling at a slower speed, was able to avoid the obstacle.

The jury found the driver of the stopped vehicle guilty of dangerous driving and criminal negligence causing death, and in the sentencing the judge famously said that ducks were not worth the lives of human beings.

But what if, instead of stopping for ducks, the driver had stopped for a person lying injured in the roadway? For example, what if the driver had stopped for a motorcyclist lying injured in the roadway, one who had been ejected from their vehicle after an accident? Or what if instead of a discretionary stop for ducks, the car had been disabled in the travel lane, without functioning emergency lights? ***In all cases, the final deadly outcome would have been exactly the same.***

In this case, by putting responsibility entirely on the source of the obstruction— a person who could have caused exactly the same obstruction without fault— the judge set a precedent that legitimizes the occurrence of fatal collisions, even when all parties follow the rules. **Highway Code that legitimizes fatal collisions is defective and a failure.**

The Highway Code must be normalized to specify that rear-end collisions are always the responsibility of the overtaking vehicle, unless the forward vehicle suddenly swerved into the lane. The driver of a vehicle unnecessarily stopped on a highway may be found guilty of unnecessarily obstructing traffic, but **must not** be held responsible for any resulting rear-end collision.

2.6 Repeal and replacement of Provision 487 of the Highway Code

With these fundamental principles in mind, Provision 487 of the Highway Code should be repealed, and replaced with the following five provisions:

(1) A motor vehicle may travel adjacent to a bicycle (such as by sharing the same travel lane, or travelling in a lane adjacent to a designated bicycle lane) when it is safe to do so. This means that the motor vehicle must allow enough space for each and all of the following:

- a minimum of 0.3 metres between the track of the bicycle and the edge of the roadway, if the area past the edge is nevertheless safely rideable;
- a minimum of 0.5 metres between the track of the bicycle and a curb, or the edge of the roadway when the area past the edge is not safely rideable;
- a minimum of 1.25 metres between the rear limit of the bicycle and rider, and any adjacent parked cars, unless the bicyclist is riding at walking speed or slower;
- the minimum passing distance as prescribed in Provision 341 of the Code (1 metre when the overtaking vehicle is travelling at speeds of 50 km/hr or less, 1.5 metres at greater speeds).

Motor vehicles may not share a lane side by side with bicycles when the bicycle is travelling at speeds of 40 km/hr or more. Motor vehicles may not share a turning lane with bicycles on their turning side.

When any circumstance holds that makes it unsafe for a motor vehicle to share a lane with a bicycle, the bicyclist should move to near the centre of the lane, to help indicate this to the motorist.

(2) When the following circumstances jointly hold:

- the travel lane is not wide enough to allow a motor vehicle to safely share it with a bicycle;
- the bicycle is travelling slower than overtaking traffic or the speed limit, whichever is slower;
- there is no available adjacent lane (whether same-direction, or else opposite-direction but free of oncoming traffic) for overtaking traffic to use as a passing lane;
- the above are the case for a length of time sufficient to cause a notable delay;

Or when the bicyclist sees that the above are about to hold—

Then the bicyclist should, at the first safe opportunity, pull over or slow down sufficiently to allow the overtaking traffic to safely pass, before resuming course and speed.

(3) As with every other vehicle operator, bicyclists should operate their vehicles at a safe distance from parked motor vehicles and from the road edge. In particular, when they cannot determine whether a parked motor vehicle has an occupant who may potentially open a door in their path— such as when passing a series of parked motor vehicles, rather than one or two isolated ones— they should ride with a spacing of no less than approximately 1.25 metres from the parked vehicle, unless they are riding at walking speed or slower, and with extra caution.

(4) Bicyclists should never remain beside or ride through on the turning side of turning or potentially turning vehicles. At stops, they should not wait on the turning side of potentially turning vehicles, but stay either ahead of or behind them, in the centre or on the opposite side of the lane, or in the next non-turning lane. They should not linger in the blind spots of any vehicle.

(5) The operator of an overtaking vehicle is always fully and solely responsible for any rear-end collision, unless the forward vehicle suddenly swerved into the lane.

2.7 How the modified provisions would have prevented the deaths described on page 1 of this document

Suzanne Squire was a conscientious bicyclist who obeyed the Highway Code. She was killed because in obeying the Code, she was riding adjacent to parked cars. Consequently she reflexively swerved to avoid an opening car door, which put her in the path of an overtaking bus. As a conscientious cyclist who obeyed the Code, if the provisions of the Code had been modified as proposed here, she would have been doubly protected: she would not have had to avoid the car door, and in the narrow lanes of the street where she was killed, the bus would have used the adjacent same-direction travel lane to pass her.

Mathilde Blais was a conscientious bicyclist who obeyed the Highway Code. She was riding a Bixi with permanently activated rear flashing lights. She was killed because in obeying the Code she was riding at the extreme right edge of the roadway in a narrow segment of a travel lane. She was crushed under the wheels of a wide overtaking vehicle, whose cab gave poor visibility to the right. As a conscientious cyclist who obeyed the Code, if the provisions of the Code had been modified as proposed here, she would have been riding in the centre of the travel lane, where she would have been easily visible to the overtaking driver, who would not have been allowed to pass. Alternatively, as a conscientious cyclist who obeyed the Code, if the provisions of the Code had been modified as proposed here, upon seeing that a narrowed segment was upcoming, she would have pulled over before reaching it, and allowed the wide overtaking vehicle to safely pass before safely resuming her journey.

Justine Charland St-Amour was a conscientious bicyclist who obeyed the Highway Code. She was killed because in obeying the Code, she was on the right side of a right-turning vehicle. As a conscientious cyclist who obeyed the Code, if the provisions of the Code had been modified as proposed here, she would have been riding in a safe position, out of the path of the truck that crushed her.

Nusrat Jahan was a conscientious bicyclist who was riding in an Ottawa bicycle lane. She was killed because the lane put her on the right side of a right-turning vehicle. If the provisions of the Ontario Highway Traffic Act had been modified as proposed here, she would have been riding in a safe position, out of the path of the truck that crushed her.

2.8 A recommendation for the safety and convenience of *all* users of the public roads: *stop installing barrier-separated on-street bicycle sidepaths and painted bicycle lanes— repeal and replace edge-of-roadway rules instead.*

Dedicated bicycle paths with their own right of way that cross few junctions— such as paths made out of old rail beds, or that go along canals— make sense and can be a pleasure to ride on.

An on-street barrier separated bicycle path is properly termed a bicycle *sidepath*, because it is functionally identical to a pedestrian *sidewalk*: for the sake of giving bicyclists a specially delineated path between intersections, at every intersection it puts users on the turning side of turning vehicles.

This fundamental safety problem, though very real for pedestrian sidewalks and the source of many pedestrian injuries and fatalities, is in their case nevertheless mostly manageable. The benefits of pedestrian sidewalks between intersections are also worthwhile: pedestrians want to be able to stop and start arbitrarily along their way, without having to obey standardized traffic patterns; while pedestrians move slower, and so come across intersections less frequently in time. And when they do come to intersections, they can focus their attention and cross safely, especially with the aid of straight through green arrows or dedicated pedestrian signals.

Compared with pedestrian sidewalks, bicycle sidepaths have fewer advantages between intersections, and much worse problems at intersections. The advantages between intersections are reduced because generally, bicyclists are not much interested in stopping and starting arbitrarily along their way, without obeying standard patterns of traffic flow; while they move much faster than pedestrians, and so come across intersections more frequently in time. And when they do come to intersections, they are not nearly as manoeuvrable and do not have the same ease of vision in all directions. Bicycle-specific signal phases can help mitigate these problems, but introduce a new fundamental problem: every new signal phase dedicated to a single user type cuts the green time of *all* users. The addition of pedestrian-specific signal phases is tolerable but bad enough; add bicycle-specific phases and everybody's frustration limit is surpassed, leading to frequent violations and back again to unmanageable safety problems.

If Provision 487 of the Highway Code were repealed, and replaced with the spacing requirements suggested here, then the clamour for bicycle sidepaths would largely disappear: bicyclists would have a safe place on the road, without introducing all the safety problems and inconveniences of sidepaths.

Bicycle sidepaths are the most expensive and most impractical response to the problems between intersections that are forced onto bicyclists by the obligation to keep to the edge of the roadway. Yet they do nothing to mitigate the problems at intersections caused by that obligation, rather they only make them worse. At the same time they make life much worse for motorists, because they cause unmanageable and anxiety-inducing delays at intersections and when exiting the vehicle, eliminate parking spots, or permanently take away at least one travel lane.

Save enormous sums of money— eliminate unmanageable and anxiety-inducing delays at intersections and when exiting vehicles— gain parking or a traffic lane for motorists, while giving bicyclists the ability to use the full lane whenever they need it— simplify snow clearing and maintenance— **and improve safety.** These are the benefits that come from not building more sidepaths, or even removing some, and changing the Highway Code instead.

Important note: some recent epidemiological studies have suggested that bicycle sidepaths are in fact safer than riding on streets without them. These studies, whose authors were already politically in favour of sidepaths (or who in the past even profited from designing them), got these results because of major flaws in their study designs. See:

Kary M (2015). Unsuitability of the epidemiological approach to bicycle transportation injuries and traffic engineering problems. *Inj Prev* 21:73-76. <http://injuryprevention.bmj.com/content/21/2/73.full>

Kary M (2014). Vulnerabilities of the case-crossover method as applied to transportation injuries and traffic engineering problems. http://injuryprevention.bmj.com/content/19/5/303/reply#injuryprev_el_10126

Kary M (2012). Still more errors and omissions. http://injuryprevention.bmj.com/content/17/2/131/reply#injuryprev_el_9295

Kary M (2012). Compendium of errors and omissions in Risk Of Injury For Bicycling On Cycle Tracks Versus In The Street, or: What is not in this article. http://injuryprevention.bmj.com/content/17/2/131/reply#injuryprev_el_8021

3. Equipment provisions of the Code

Bicycles are lightweight, relatively fragile, and often maintained and repaired by their owners. Their size must match that of their rider, and they should be able to draw all of their power from the rider's muscular effort. They need to be easily disassembled, e.g. for travel on trains and planes, or just for maintenance. They are typically parked outdoors, where they are susceptible to theft and vandalism, both of the bicycle itself and of any individual component. As a result their equipment must be lightweight, simple, efficient, easy to service, adaptable, and durable; and ideally, easily removable, whether for maintenance or secure storage.

The fundamental principles that should govern the Highway Code's equipment specifications should therefore be:

- to set a reasonable minimum standard
- to allow flexible implementation
- to not require any superfluous or dangerous item.

The current Highway Code fails on all three counts.

3.1 Braking

Provision 247 of the Code states that

Every bicycle and non-motorized scooter must be equipped with at least one brake system acting on the rear wheel. The system must be sufficiently powerful to quickly block the rotation of the wheel on a paved, dry and level roadway.

Yet blocking the rear wheel is an ineffective and unsafe stopping method. On the other hand a well-functioning front brake is far more effective than any rear brake.

Provision 247 as it applies to bicycles should therefore be changed to read as follows:

Every bicycle must be equipped with at least one brake system in good working order, acting on either the front or rear wheel. A rear brake system must be sufficiently powerful to quickly block the rotation of the wheel on a paved, dry and level roadway.

Public safety officers should be informed that fixed gear bicycles (track bicycles and "fixies"), even when they have no hand brakes, normally come automatically with a braking system that meets the standards of the code: exerting the legs counter to the rotation of the cranks is generally sufficient to meet the standard.

3.2 Lighting

(Note: in the following, "lighting" refers to any combination of lights and reflectors.)

3.2.1 Comparison of the standards for bicycles and motorcycles

Motorcyclists are more vulnerable to death and injury than bicyclists, because even though they wear marginally more protective clothing and their vehicles have better suspension systems, they travel much faster and frequently ride in more dangerous traffic. Their death and injury statistics certainly bear this view out. Worse, they are a much greater danger to other road users, because of their much greater masses and speeds.

Motorcycles also have far more power and mounting options available for accessories, do not rely on physical exertion of the rider for operation, are less likely to be maintained by their owners as home mechanics, and are far more secure against theft, whether of the vehicle or its components. Yet compare the relevant lighting provisions of the Highway Code for motorcycles against those for bicycles:

For motorcycles: Provision 230. Every motorcycle or moped must carry at least

(1) one white headlight;

(2) one red tail-light

(there are two additional provisions for stop and turning lights which are not relevant here)

For bicycles: Provision 232. Every bicycle must carry at least

(1) one white reflector at the front;

(2) one red reflector at the rear;

(3) one amber reflector on each pedal;

(4) one reflector attached to the spokes of the front wheel;

(5) one reflector attached to the spokes of the back wheel.

Any equipment or object placed on a bicycle that blocks a prescribed reflector must be provided with a reflector that complies with the first paragraph.

Provision 233. At night, every bicycle must also carry, at least one white headlight and one red tail-light.

Provision 233.1. No bicycle dealer shall sell, offer for sale, rent or offer for rent a bicycle unless the bicycle carries the reflectors prescribed by section 232.

*Even though motorcycles move faster and are thus more difficult to identify, are ridden in more dangerous traffic, are more easily equipped with extras, and are more dangerous to their riders and to others, **the lighting requirements for motorcycles are far less than for bicycles.***

3.2.2 Rational lighting requirements

The above alone shows that the current lighting requirements for bicycles are not based on any rational safety analysis. In particular:

-Reflectors are required during daylight hours, **yet they are of no use during daylight hours.** Most bicyclists only ride during daylight hours, and unlike cars, bicycles are never

parked overnight in the roadway.

-Front and rear lights are required at night, and **these render all but the rear reflector superfluous**. Bicycle front and rear lights have sufficient side spillover to make the bicycle clearly visible from the sides. Any additional reflectors or lights go beyond a reasonable minimum standard and should be optional, not mandatory.

-**No vehicle other than bicycles has ever been required to have rotating reflectors** (such as on pedals or spokes), or reflectors that otherwise move against the position of the vehicle. There is a good reason for this: obviously, **motion against the direction of the vehicle confuses perception of the vehicle's direction and speed**.

-**The only study of the safety effect of spoke reflectors found that they were associated with a significant increase in the risk of collisions at night**. (See Elvik R, Høye A, Vaa T, Sørensen M, 2009. The Handbook of Road Safety Measures, 2nd edition, p. 673. Emerald Group Publishing: Bingley, UK.)

In fact the reflector provisions of the Quebec Highway Safety Code are merely copied from the same regulations enacted in the 1970s by the US Consumer Products Safety Commission. In turn, those regulations were enacted in a misguided attempt to avoid making lights mandatory, in response to complaints from the bicycling industry. These reflector provisions are harmful in two basic ways.

First, despite the Code's requirement that lights be used at night, lights are extras while bicycles must be sold festooned with reflectors. This leads users to believe the reflectors are sufficient for night riding. This belief is mistaken, because:

-The front reflector is not lit by the headlights of oncoming cars turning left across the rider's direction of travel. This is the classic "left hook", a notoriously deadly accident type.

-The side reflectors (tire or spoke mounted) are not lit by side traffic until the bicycle enters the intersection, when it is either too early or too late.

-The reflector design adopted by the CPSC for the rear is unnecessarily wide-angle, making it very dim even when lit by overtaking traffic. (SAE-standard red reflectors are much brighter, and SAE-standard amber reflectors are much brighter still. Their angle of reflection is all that is needed for safe operation, as evidenced by their use on motor vehicles.)

Second, all these reflectors interfere with the proper operation and easy maintenance of the bicycle, because:

-The front reflector is typically mounted through the brake bolt.

-Pedal reflectors typically cannot be used at all with most modern pedal systems, and they interfere with easy entry and exit from other standard designs.

-Reflective material on tire sidewalls makes the casings stiffer, thereby increasing the rolling resistance of the tire and the effort required to pedal at any given speed.

-Reflectors attached to spokes can create aerodynamic instability at the speeds often attained on downhills, and some designs can loosen spokes. **In cross winds they add an oscillating steering motion to the front wheel that is particularly dangerous on downhills**. (The cyclists who would face this problem typically remove spoke reflectors and avoid it.)

(For further information on all these matters, the reader is strongly advised to consult in addition: <http://bikexpert.com/bicycle/reflectors/index.htm>)

In short, the current lighting provisions of the Code are at once superfluous, inadequate, **and harmful**. Provision 232 should be repealed in its entirety, and Provisions 233 and 233.1 should be replaced with the following provisions:

233. When riding at night, every bicycle must be equipped with a front white headlight with side spillover, and a rear amber or red reflector or tail light. The minimum standard for the rear is a red CPSC-standard reflector. The recommended standard is an amber SAE-standard reflector, or failing that a red SAE-standard reflector, coupled with a red or amber tail light.

233.1 All new bicycles offered for sale, and all bicycles offered for rent, must be equipped with a rear amber SAE-standard reflector.

These modified provisions represent substantial improvements in both safety and convenience, and come at reduced purchase cost.

4. Stop signs

It is obviously unsafe for anyone, whether as pedestrian, motorist, or bicycle rider, to go through a stop sign when the way is not clear. Yet in most cases, no road user needs to come to a dead stop in order to check whether the way is clear, and in fact it is often impossible to check whether the way is clear without advancing through the stop line. Dead stops may be required though when the way is not clear, in order to yield the right of way.

Far more than for motorists, stop signs are a problem for bicyclists because they greatly increase the physical exertion required for a journey. For example, both calculations and experiments show that in typical conditions, in order to maintain a constant speed on a level street having stop signs every 300 feet, compared with no stop signs the rider must increase their efforts almost five-fold (see <http://nacto.org/wp-content/uploads/2012/06/Fajans-J.-and-M.-Curry.-2001..pdf>). Put another way, typically each stop sign is approximately equivalent to riding an extra 100 metres, so that 10 stop signs are equivalent to riding an extra kilometre. For this reason alone there is a strong and unavoidable incentive for bicycle riders not to come to complete stops at stop signs. The situation is still worse when the stop sign occurs on an uphill.

Consequently, in this perhaps more than in any other circumstance, if the provisions of the Code overreach, to go beyond what is needed for the safe operation of the roads, bicyclists will become contemptuous of them, and descend into more and more genuinely unsafe behaviours— exactly as is already the case today.

With these considerations in mind, the various stop sign provisions of the code as they apply to bicyclists should be consolidated and amended to read:

-When approaching an intersection regulated by a facing stop sign or red flashing light, the bicyclist must:

-Slow down sufficiently to check that the way is clear, without interfering with the right of way of either unregulated cross traffic, or regulated cross traffic that arrived at the intersection before the bicyclist; or in the case of simultaneous arrival, that comes from the right.

-Yield the right of way to unregulated cross or turning traffic, or regulated cross or turning traffic that arrived at the intersection before the bicyclist; or in the case of simultaneous arrival, that comes from the right.

-Proceed through the intersection only when the way is clear, either by there being no traffic, or by other users at or near the intersection having yielded the right of way.

Note that in these provisions, "traffic" is taken to mean any road users, whether pedestrians, motorists, or bicyclists.

5. Signalling

Signalling the intention to turn or stop creates special problems for the bicyclist. Turn signal and stop lights are not practical, and signalling using the arms requires removing one hand from the handlebars precisely at a moment when careful control of the bicycle and use of the brakes may be required. Further, the hand that is removed from the bars is typically the left hand, which normally controls the front brake. The front brake is the only useful brake when rapid deceleration is required. In any case, during emergency braking, the rider must have both hands firmly on the handlebars, in order to be well-braced enough to avoid being ejected from the bicycle.

With these considerations in mind, Provision 490 of the Code should be changed to read:

When turning or slowing down may cause the trajectory of the bicycle to come into conflict with other road users who are unaware of the intended change, the rider should signal the intention to turn or slow down using the corresponding hand signal.

6. Sidewalk riding

Riding on the sidewalk may cause a bicycle rider to come into sudden conflict with other users entering or exiting driveways; at intersections; and with other users of the sidewalk, which is often narrow and obstructed.

Yet many marked bicycle paths provided by municipal authorities *are* on the sidewalk, such as on Chemin de la Grand Côte on the Lower North Shore, or on Gouin Boulevard in Saint Laurent. If riding on a sidewalk is hazardous, painting pictures of bicycles on it will not make it safe. Nevertheless, riding on the sidewalk may allow some cyclists to safely navigate areas that would otherwise be particularly dangerous for them.

Riding on the sidewalk can be safe enough in various combinations of these circumstances:

- There are few or no others using the sidewalk at the same time.
- The sidewalk crosses few driveways or intersections.
- The sidewalk is sufficiently wide.
- Riding is done at walking speed.
- The rider proceeds with extra caution, especially near junctions.

With these factors in mind, the Highway Code should be modified to allow bicyclists to ride on

the sidewalk when it can be done without interfering with pedestrian or cross traffic. This requires in particular coming to driveways and intersections at walking speed or slower, until it can be established that the way is clear; and not riding within 1.5 metres of pedestrians, unless cautiously at no more than walking speed.

7. Miscellaneous bicycling provisions in need of change

7.1 Right to ride in standard manners

7.1.1 Provision 477 as it applies to bicycles currently reads as follows:

477. A person riding a bicycle must sit astride the bicycle and keep hold of the handlebars.

Yet it is perfectly normal, and e.g. when climbing hills often necessary, to ride while standing out of the saddle. It is also perfectly normal, and in common circumstances often desirable, to ride with the hands released from the handlebars. Riding without hands is also part of the learning experience of mastering control of the bicycle. Enforcement of Provision 477 can never be more than sporadic, and likely almost never occurs. The provision serves no useful safety purpose, is contrary to normal bicycle operation, is an overreach, and should just be repealed.

7.1.2 Provision 485 currently reads as follows:

485. No person riding a bicycle may take a passenger unless his vehicle is equipped with a fixed seat for that purpose.

It is a completely reasonable, normal, and enjoyable part of childhood to double ride on low-traffic residential streets or in parks. Adults rarely double ride, if only because their size and the configurations of adult bicycles generally make this impractical. The provision should be replaced as follows:

485. No person shall ride or be a passenger of a bicycle in such a way as to endanger others through lack of control, whether of the bicycle or of their own position on the bicycle.

7.1.3 Riding side by side

Provision 486 currently reads as follows:

486. When riding in groups of two or more, cyclists must keep in single file; in no case may such a file be composed of more than 15 cyclists.

This provision inconveniences both bicyclists and motorists. Riding side by side shortens the length of the file, and the time it takes the motorist to overtake, by half. Riding single file makes it difficult for riders to communicate with each other, and reduces the pleasure of riding in a group. The astute observer of Quebec roadways will note that police bicycle patrollers routinely ride side by side, to the inconvenience of no one. The writer of this sentence has also observed police cadets riding side by side in groups of many more than 15.

Provision 486 should be repealed and replaced as follows:

Bicyclists should not ride side by side when doing so obstructs overtaking traffic. When a travel lane is not wide enough to be safely shared between a single bicycle and motor vehicle traffic [as described in the modified Provision 487 proposed here], bicyclists may travel side by side [in accordance with the qualifications of the modified provision 487]. Bicyclists may also ride side by side in wide lanes, provided they revert to single file when necessary to avoid impeding the progress of overtaking traffic.

8. The needs and rights of pedestrians

8.1 Two fundamental principles of traffic safety

Any behaviour, even if it obeys a Highway Code, is unsafe if done inattentively or without due caution.

Any behaviour, even if it disobeys a Highway Code, is safe and fair, so long as all of the following hold:

-It does not impede any traffic having the right of way.

-It is done attentively and with due caution— to identify road hazards, to identify others having the right of way, or with regard to the possibility that others may violate a right of way.

-The sight lines are adequate to allow these.

8.2 A fundamental right to use the public roads:

The Highway Code should be modified so that any pedestrian respecting the above safety and priority conditions can never be cited for an offence and is never guilty of a violation.

The reason that bicyclists and motorists must be excluded from this fundamental right is that, due to their speed, reduced manoeuvrability, and reduced sight lines, they cannot maintain these conditions without the help of standardized flow patterns or traffic control devices.

8.3 The hazards of pedestrian sidewalks

Sidewalks, just like barrier-separated on street bicycle paths or painted bicycle lanes, and just like riding on the far right according to Provision 487 of the Highway Code, all present the same fundamental hazard illustrated on the cover page of this document: at every intersection, they put through traffic (pedestrians or bicyclists) on the turning side of turning traffic. Nevertheless they are of benefit to pedestrians, who want to be able to travel between intersections stopping and starting at will, without paying attention to other traffic. At intersections, which at walking pace pedestrians encounter at relatively widely spaced time intervals, pedestrians can focus their attention on the unavoidable resulting traffic conflicts, and deal with them with the help of traffic control devices, such as straight-through only arrows or pedestrian signals. However, these mitigating factors do not hold true for runners in the same way as for walkers.

8.4 Running in the roads

Sidewalks pose special hazards for runners. Because of their speed, at driveways and intersections runners face the same dangers as do bicyclists who ride on sidewalks. In fact runners typically travel faster than bicyclists on sidewalks, because sidewalk riders are typically riding there because they are slow and inexperienced. In the winter, sidewalks are often poorly cleared and icy. Winter and summer, sidewalks are tilted for drainage, and running on tilted surfaces for prolonged periods can aggravate or cause serious injury. Pedestrians on sidewalks have the right to suddenly and unpredictably change directions, easily causing collisions with overtaking runners, potentially leading to serious injury of either party.

On residential streets, there is typically no safety issue to prevent solitary or small groups of runners from running down the centre of the road facing traffic. Nor is there any issue of interfering with the right of way of motorists or bicyclists: runners in the centre of the road can easily see and get out of the way of approaching traffic— including vehicles entering the road from driveways or parking spaces— long before there is any conflict. **Doing so improves safety for runners, reduces delays for drivers exiting driveways, avoids conflicts with walkers, and has no real downside.**

With these considerations in mind, the Highway Code should have two provisions added as follows:

(1) On residential streets, one or a group of two runners may run near the centre of the travel lanes facing traffic, as long as:

- they move to the side to yield the right of way to any approaching traffic;
- they do so promptly, so as not to interfere with or impede the progress of any approaching traffic;
- the road's sight lines are adequate to safely allow these actions.

(2) On all streets, pedestrians are allowed to enter the roadway to circumvent a driveway, provided they can do so without interfering with or impeding the progress of any overtaking or oncoming traffic.

Because of their speed, acceleration, manoeuvrability, and ease of 360 degree vision, as part of the fundamental right of pedestrians to use the public roads, runners should further be allowed to proceed through intersections on red lights, as usual after first verifying that there is no conflicting traffic, providing they can easily complete the manoeuvre without interfering with any other user's right of way, and providing the sight lines are adequate to safely allow these actions.

8.5 Walking in the roads

Every Canadian is familiar with this situation: a residential roadway is completely free of ice or debris; while the adjacent narrow pedestrian sidewalks are icy, broken up, or strewn with debris, such as garbage awaiting collection. And most of the time these residential streets remain free of vehicle traffic, while the hospital emergency wards overflow with people injured using the sidewalks.

Winter and summer, the roadway will always be better cleared and drier than the adjacent sidewalks, because of its position in the centre of the street, where it is sunnier; because of its darker colour; and because motor vehicle traffic helps to clear the snow and any other debris. The roadway also has better sight lines near driveways and intersections, and generally fewer obstructions.

The highway code should be modified to allow pedestrians to use the roadway facing traffic, provided:

- they exercise due caution;
- they move to or remain at the side so as not to interfere with any approaching traffic;
- the road's sight lines are adequate to safely allow these actions.

8.6 Right to play in residential streets

Playing hockey or other games in residential streets is a normal and safe activity. The right to play in residential streets is superior to the (non-existent) right to inattentively speed through them. The highway code should be modified to guarantee the right to play in residential streets, as long as due caution is taken, play is promptly suspended to allow any traffic to pass through (whether motor vehicle, bicycle, or pedestrian), and the road's sight lines are adequate to safely allow these actions.

8.7 Right to behave normally

Consider a person living on a residential street, halfway between two intersections, with their car parked directly across the street. Or the same person wishing to visit their neighbour across the street. It is completely normal to simply cross the street mid-block to get to the other side, despite the fact that this behaviour contradicts the Highway Code.

In accordance with their fundamental right to use the public roads, the Highway Code should be changed to allow this completely normal behaviour that is also completely safe, as long as due caution is taken, the right of way of any approaching traffic is respected, and the sight lines are adequate.

Young children and those with reduced mobility, such as the elderly, are often incapable of meeting these requirements. *Yet the elderly especially are tempted to cross midblock if the intersections are distant for them, in the expectation that cross traffic will see them and yield. They will be less tempted if, instead of overreaching by banning entirely this otherwise normal behaviour, the Highway Code instead specifies when it is and is not safe, as described above.*

8.8 Pedestrian crossing signals

The purpose of the white pedestrian crossing signal is to give pedestrians a protected signal phase, so that they can cross the street without conflict from turning traffic. In Quebec it is common to combine this signal with a simultaneous green turn arrow, or an all-directions green light, **thus defeating the entire purpose of the pedestrian signal.** The Highway Code should be changed to prohibit these misleading and dangerous signal combinations.

9. Miscellaneous provisions

9.1 Silent electric vehicles

Vehicle noise is important for the safety of bicyclists and pedestrians. Some electric vehicles (cars and scooters) are being manufactured so as to operate essentially silently. The Highway Code should be changed to require they operate with a standard noise similar in volume to that of an ordinary motor vehicle.

9.2 Overly bright emergency lights

The progress of LED lighting has allowed emergency vehicles such as police cruisers and ambulances to be equipped with exceptionally bright lights. **The brightness level of many of these lights is sufficient to harm the retina when looked at directly, even from relatively great distances.** Some motor vehicle low beam running lights are also becoming excessively bright. The Highway Code should be changed to safely limit the brightness of any lighting visible on the public roads.

10. Closing remarks

The only legitimate purpose of a Highway Safety Code is to ensure *for all persons* the effectiveness, efficiency, and safety of the public roads. And all of that is only for the convenience and pleasure of the population. Superfluous requirements, abnormal traffic flows, the over-regulation of ordinary life, and turning every road user who is not in a motor vehicle into a second-class human being, all work to the detriment of those legitimate goals. They make bicycling in particular unsafe and even terrifying. The result has been a clamour for barrier-separated on-street bicycle paths— the most expensive and impractical response— and, ironically considering their underlying idea of getting bicyclists out of the way of motorists, the one most inconvenient to motorists.

Purging the Highway Code of those elements noxious or inimical to bicyclists and pedestrians, as described in this brief, will work to the benefit of *all* road users— *including motorists*.